



Technical catalogue

Distribution switchgear General catalogue

Power and productivity
for a better world™



Distribution switchgear

General Catalogue

Presentation of the range

1

Gemini switchboards

2

ArTu L modular structures

3

ArTu M monobloc structures

4

ArTu K modular structures

5

In-depth technical information

6

Selection and design tools

7

Overall dimensions

8

Ordering codes

9

Gemini. Something completely different in switchboards.



Gemini. Quality and safety.

ABB's Gemini is designed and built in compliance with reference Standards that define its constructional and functional characteristics. In particular, the IP66 degree certifies that Gemini is totally protected against the infiltration of solid bodies and is resistant to the penetration of jets of water similar to sea waves.

Absolute protection is provided by double insulation even in the event of indirect contact. Even in very difficult application circumstances, Gemini gives high-level performances, with resistance to fire and abnormal heat up to a temperature of 750 °C and a functioning temperature from -25 °C to 100 °C.





Gemini. **Fit for all application.**

There are as many configurations as there are ABB devices for low voltage automation and distribution: moulded-case circuit breakers, modular circuit breakers, monitoring, control and signaling devices, wiring ducts and electrical connection systems.

All of these components give the “Gemini system” an enormous range of ad hoc solutions that are easy to assemble with the snap-on system.



ArTu. Go ahead and select the switchgear you need.



ArTu. A great offer, really high performances.

ABB proposes three series of switchgear with different characteristics thought up to make it possible to select the most suitable switchgear for the installation requirements. Different sizes for optimal use of the spaces available. Great savings in storage space is ensured by the rapid assembly kit containing so few pieces that skilled personnel is not required. IP degrees of protection for all types of application up to IP65 - the only switchgear to reach such a high value. Extremely sturdy and flexible, it is made for plants up to 4000A.

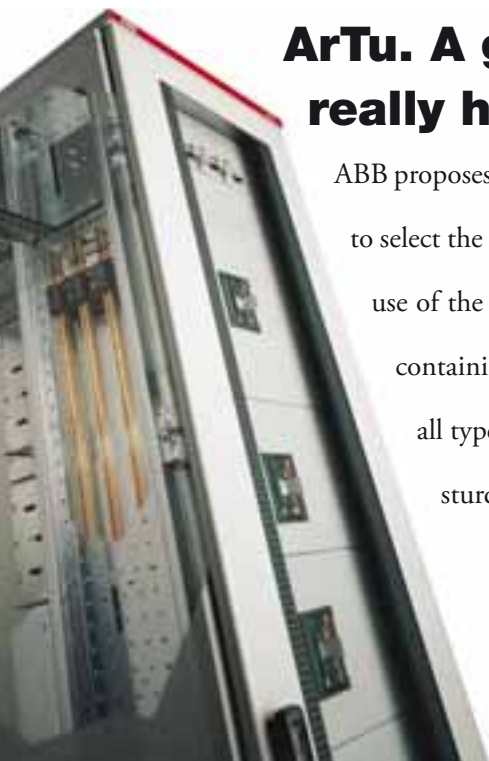



ArTu. Born certified.

Fully checked and certified (IEC 60439-1 and IEC 61439-1 and 2 Standard) by an external independent organisation (Acae Lovag), the ArTu switchgear is a synonym of safety and quality. The certification is the fruit of severe tests carried out on the whole configuration, consisting of metalwork structures, circuit-breakers and busbar system.



ArTu. A long experience through many projects.

The ArTu switchgear was born from an innovative project, created around the needs of all the professional figures involved in building and installing switchgear. This is constantly updated on the basis of the numerous projects which over these past years have had the ArTu series of switchgear as their leading player (Airports, underground railways, hospitals, industrial complexes, residential complexes, ports, tunnels, stretches of railways, theatres, etc.).

ArTu L. Everything you need simply and conveniently.



ArTu L. Why complicate your life?

Up to 800A you have a series of both wall-mounted and floor-mounted switchgear available, able to ensure a high standard of quality along with maximum simplicity of selection and assembly.

Fitted with a structure, which is completely open at the sides, means you can carry out cabling very conveniently, with the switchgear placed horizontally on two trestles. And, if we are talking about cabling, there is nothing which simplifies and speeds it up better





than the Unifix H or L wiring system, created by ABB for its modular and moulded-case circuit-breakers.

The cable riser container is available in a width of 300mm to take different busbar systems, and, furthermore, with a convenient box placed above the switchgear, increases the space available for the incoming cables.



ArTu M. Top level functionality and protection.



ArTu M. Maximum protection up to 630A.

The ArTu M series switchgear is ideal for terminal wall-mounted switchgear with modular circuit-breakers and floor-mounted secondary distribution switchgear with moulded-case circuit-breakers up to 630A.

Many versions are available, for wall-mounted installation with depths of 150 and 200mm and for floor-mounted installation, with a depth of 250mm.

The degree of protection is at top market levels, reaching up to IP65, thanks to an innovative design and advanced construction systems

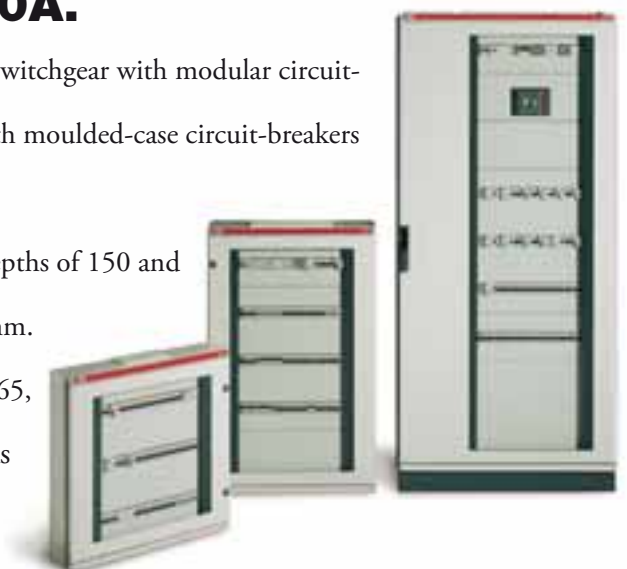



The switchgear is available in 600mm useful width, with the possibility of installing 24 DIN modules in one row, and 800mm width choosing between installation of 24 DIN modules in one row plus the cable riser, or 36 DIN modules in one row.



ArTu K. New horizons up to 4000A.



ArTu. High performances? No problem.

The ArTu K series switchgear is ideal for primary distribution switchgear (Power Center type) with air and moulded-case circuit-breakers and any internal segregations up to Form 4, and for floor-mounted secondary distribution switchgear with moulded-case and modular circuit-breakers.

The ArTu K series consists of modular switchgear for floor-mounted installation with depths of 150, 225, 300, 500, 700 and 900mm, with IP31, IP41 and IP65 degrees of protection - the highest value available on the market. Within the ArTu K series switchgear, like all the series in the range, it is possible to install ABB apparatus (System Pro M modular circuit-breakers, Tmax moulded-





case circuit-breakers, T and XT series and Emax air circuit-breakers) with an excellent and certified level of integration. The switchgear is available in three functional widths (390, 600 and 800mm) and in two functional heights (1800 and 2000mm), which allow installation of 9 and 10 modules 200mm in height respectively.



ABB SACE and its commitment to protecting the environment



ABB SACE is one of the forerunners among the companies in the Group in dedicating considerable resources towards reaching its objectives of sustainable development and environmental protection. This is confirmed by the fact that all the company manufacturing sites have been awarded ISO 9001 quality certification, ISO 14001 environmental management system certification and the majority of these have also obtained the Quality, Environment and Safety integrated management system certification.

All the company sectors are, in fact, actively involved in continuing the policy of improving environmental management by rationalizing the consumption of raw materials and energy, preventing pollution, respecting water and air, reducing noise levels to a minimum, reducing waste from production processes and carrying out periodic environmental checks at the main suppliers' premises.

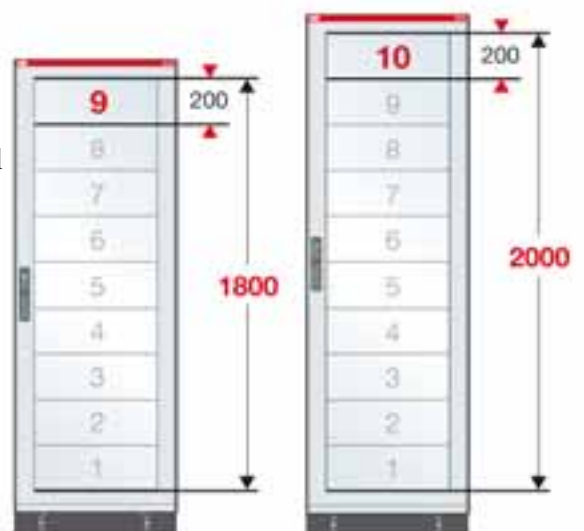
By using analysis tools such as LCA (Life Cycle Analysis), right from the initial stages, ABB SACE design activities already include assessment and improvement of the environmental performance of its products throughout their entire life cycle in order to guarantee maximum efficiency in technical and energy performance during service, control and reduce environmental impact in the manufacturing stage and define end-of-life management procedures.

All these goals and activities are the result of far-sightedness in adopting ecological policies and methods for reducing environmental impact and, here too, ABB SACE is a leader on the Italian company scene, as it already is for the quality of its products.

Certificate N°OHS-015



Certificate N°1612/98/S



Certificate N° EMS-051

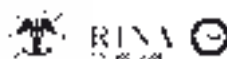

Certificate N°SGI004

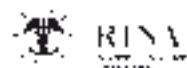



Index

Characteristics of Gemini switchboards	1/2
Characteristics of ArTu switchgears	1/4
Composition of the series	1/8

Presentation of the range

Characteristics of Gemini switchboards

Gemini is the result of design work conducted by ABB with the direct collaboration of switchboard manufacturers, installers and designers who considered versatility to be the discriminating element when purchasing a switchboard, equally as important as sturdiness and reliability.

Gemini fulfils this requirement by providing a product that can be used for three different purposes: in addition to the basic configuration it also provides the components necessary for equipping it as an automation switchboard or as a distribution and mixed switchboard.

In all applications, compatibility with ABB protection, control and monitoring products means that a real system of integrated and complementary functions can be configured.

Typical examples of some Gemini applications can be seen in installations in industrial production departments and on board machines, in galvanization plants and varnishing cabins, in petrol stations and car-washing plants, boiler-rooms, car parks, shopping malls and in any other environments where distribution and automation demand specific safety requirements and service continuity.

Gemini also has flexible measurements, with six different box sizes and internal space to accommodate from 24 to 216 DIN modules.

To respect safety standards, all the switchboard's components can be fixed to the base plate or to the box frame without having to use any tools; wiring is carried out from the front followed by snapping the base plate or the frame onto the box. The patented frame is fitted with the cable duct incorporated in the uprights.

In its design, Gemini repeats the shapes and RAL 7035 grey color of the ArTu switchboards with which it can be configured as a main protection switchboard.



Presentation of the range

Characteristics of Gemini switchboards

1

In the basic configuration, Gemini switchboards are composed of boxes in six different sizes ranging from 335x400x210 mm to 840x1005x360 mm (WxHxD, external measurements) and with opaque or transparent doors.

In both versions, the doors are reversible and clip onto the hinges without the need to use tools; the fact that they open at an angle of more than 180° means that it is easy to work on the components installed inside the switchboard. The seal applied by extrusion along the sides of the doors guarantees IP66 degree of protection.

Access to the inside of the switchboard is protected by a standard double bit lock that can be replaced by locks of another type available in the accessories.

Boxes and doors can be requested either separately or as combined “box + door” codes, to make filling out the order form more flexible.

Inside the packages, the door is always wrapped separately and inserted inside a pocket that protects it from accidental damage until wiring is completed and the switchboard is installed.

Hole-cover plugs to guarantee IP protection and double insulation for wall mounting are also supplied with the pack together with the instruction sheet.



No tools are needed for installation. The doors hook onto the hinges with special hinge pins and are reversible.



Fixing hooks and feet allow the frame to be snap-mounted inside the box.

Gemini is made in a thermoplastic material that has a very low halogen content and is 100% recyclable.

The environmental compatibility of Gemini is an important objective right from the design phase where the Life Cycle Assessment (LCA) procedure, defined in 1990 during the Society of Environmental Toxicology and Chemistry Conference (Vermont, USA), is followed. Life Cycle Assessment is an objective method for analyzing the energy and environmental loads relating to a product, process or activity, carried out by identifying and quantifying energy, the materials used and emissions released into the environment. Divided into four phases, the assessment covers the entire life cycle of the product, process or activity, from the extraction and transformation of raw materials to manufacturing and distribution, and from usage to recycling and decommissioning.

Presentation of the range

Characteristics of ArTu switchgears

The range of ABB SACE ArTu distribution switchgear provides a complete and integrated offer of monobloc metalwork structures and kit systems for main and sub low voltage distribution switchgear, which satisfy all plant requirements depending on the type of installation, degree of protection required, and electrical and mechanical characteristics.

Starting from simple assembly kits, the ArTu switchgear allows numerous switchgear configurations:

- for Power Center type main distribution, with a prevalence of air circuit-breaker and moulded-case circuit-breakers and any internal segregations up to Form 4;
- for floor-mounted secondary distribution, equipped with moulded-case and modular circuit-breakers;
- for wall-mounted end distribution, with just modular circuit-breakers.

The user of ABB SACE circuit-breakers can therefore have a complete system of enclosures, in accordance with the reference standards, which guarantees absolute compatibility between the various elements (enclosures, circuit-breakers and distribution systems), together with maximum assembly and cabling facility. Special consideration has been given to cabling requirements, foreseeing dimensions of the structure, but also providing special seats for fixing the plastic cabling duct horizontally and vertically.

The ArTu switchgear is noted for the following features:

- integrated range of modular metalwork structures up to 4000 A with common accessories;
- possibility of fulfilling all application requirements in terms of installation (wall-mounting, floor-standing, monobloc, corner versions and cabinet kits) and degree of protection (IP31, IP41, IP43, IP65);
- maximum integration with modular apparatus and the moulded-case and air circuit-breakers, so that additional drilling or adaptations are not required;
- minimum switchgear assembly times, thanks to the simplicity of the kits, standardisation of the small assembly items, self-supporting elements and the presence of clear reference points for assembly of the plates and panels;
- segregations in kits up to Form 4;
- use of the Unifix rapid cabling system.



The range of ArTu enclosure structures allows construction of numerous switchgear configurations



The ArTu switchgear allows segregations up to Form 4 to be made

Presentation of the range

Characteristics of ArTu switchgears

The use and installation of the kits according to the instructions provided means that assembly and cabling times can be reduced to a minimum, for example thanks to the reference points for positioning the panels and plates, and that respect of the insulation distances and the rated characteristics of the circuit-breakers are guaranteed.

The ArTu range includes three different series of switchgear, which are completed with the same accessories:

ArTu L series

This consists of a range of modular switchgear kits, with a capacity of 36 modules per row and IP31 degree of protection (without door) or IP43 (basic version with door). Installation can be either wall or floor-standing:

- Wall-mounted ArTu L, with 600, 800, 1000, and 1200mm (useful) heights, 165mm depth, 600mm width. It allows installation of the modular System pro *M* apparatus, and moulded-case Tmax T1-T2-T3 circuit-breakers, XT1 and XT3 circuit breakers.
- Floor-standing ArTu L, with 1400, 1600, 1800, 2000mm (useful) heights, 195 mm depth, 600mm width. It allows installation of the modular System pro *M* apparatus and moulded-case Tmax T1...T6 800A circuit-breakers (fixed version with front terminals); XT1...XT4 (fixed version with front terminals).

ArTu M series

This consists of a range of monobloc switchgear for wall-mounted installation (with depths of 115 and 165mm and with IP65 degree of protection) or floor-standing installation (with depth of 195 mm and IP31 or IP65 degree of protection), where it is possible to mount System Pro *M* modular apparatus and Tmax T1, T2 and T3, XT1 and XT3 moulded-case circuit-breakers on a DIN rail.

In the wall-mounted versions ($D = 165$ mm), the Tmax moulded-case circuit-breakers up to 250 A can be installed, whereas in the floor-mounted versions, the moulded case Tmax T series up to T6, XT series up to XT4 circuit-breakers can be installed.

ArTu K series

This consists of a range of modular switchgear kits for floor-standing installation with six different (useful) depths: 150, 225, 300, 500, 700 and 900 mm, and with IP31 degree of protection (without front door), IP41 (with front door and side ventilated panels) and up to IP65 (with front door and blind side panels). It is possible to install System Pro *M* modular apparatus, the ranges of T and XT series circuit-breakers in all their possible configurations, and Emax X1, E1, E2, E3 and E4 air circuit-breakers.



Use and installation of the kits, according to the instructions provided, allow assembly and cabling times to be reduced to a minimum.



Presentation of the range

Characteristics of ArTu switchgears

The ArTu switchgear has the following functional widths:

- 390 mm, for installation of moulded-case circuit-breakers up to 1600 A (T7);
- 600 mm, which is the basic dimension for installation of all the apparatus;
- 800 mm, for making the lateral cable container inside the structure of floor-mounted switchgear or to use panels with 36 DIN modules in one row.

The panels for Tmax, and Emax circuit-breakers have 100 mm modularity.

The useful inside height space varies from 600 mm (L wall-mounted series) to 2000 mm (L and M floor-standing series and K series), offering optimisation and automatically reducing the spaces taken up by the switchgear.



The panels for Tmax, and Emax circuit-breakers have 100mm modularity



With the shaped section busbar system, ArTu switchgear for low voltage power distribution further enhance perfect integration with the apparatus and, in full conformity with the IEC 60439 Standard, can be certified by carrying out only the individual tests.

Using Artu enclosures and relative accessories together with modular apparatus and moulded-case and air circuit-breakers, it is therefore possible to build AS or ANS type switchgear without carrying out further type tests, simply respecting the selection criteria and the assembly instructions for the various components.

The ArTu distribution system consists of:

- shaped section copper busbars with capacity from 400 A to 3200A;
- flat copper busbars up to 4000A;
- busbar holders and relative crosspieces for short-circuit withstand up to 105kA;
- flexible busbars for connection of the moulded-case circuit-breakers and screws and hammer for connection of the latter to the shaped section busbars.



The ABB SACE busbar system and accessories for installation in the distribution switchgear

Presentation of the range

Characteristics of ArTu switchgears

A peculiarity of the shaped section busbar system is its extremely compact dimensions, which allow it to be assembled directly inside the cable container, on the back or on the side of the structure, keeping front access. This is possible thanks to the scaled or linear type busbar holders, which also allow assembly in the L or M floor-mounted series of switchgear, with reduced dimensions.

The ABB SACE busbar and accessories system prepared for installation in ArTu distribution switchgear undergoes the short-circuit withstand tests with a value of I_{sc} up to 4000 A and I_{cw} up to 105 kA (1s) according to the IEC 60439-1 Standard, in ABB laboratories recognised by ACAE/LOVAG.

The Unifix rapid cabling system, which allows simple, rapid and safe cabling of all the ABB SACE apparatus, completes the switchgear. Unifix is available in two versions: the Unifix H series, suitable for structured cabling of moulded-case circuit-breakers up to 250A (T series up to T3 and XT series with XT1 and XT3) and modular System Pro-M circuit-breakers, and the Unifix L series, specifically for rapid cabling of modular System Pro-M circuit-breakers.

A fundamental characteristic of these systems is the possibility of combining different types of circuits (single-phase/three-phase/auxiliary) within a single module. Unifix also allows bench cabling to be carried out, and to then only install it in the switchgear at a later time, without any limitation of the types or combinations of apparatus which can be installed. This way cabling times are considerably reduced, making realisation of the power supply by means of cables superfluous, as the rigid coupled connectors - standardised for the different types of apparatus - do, in fact, see to this.



The Unifix rapid cabling system



Presentation of the range

Composition of the series

ArTu L

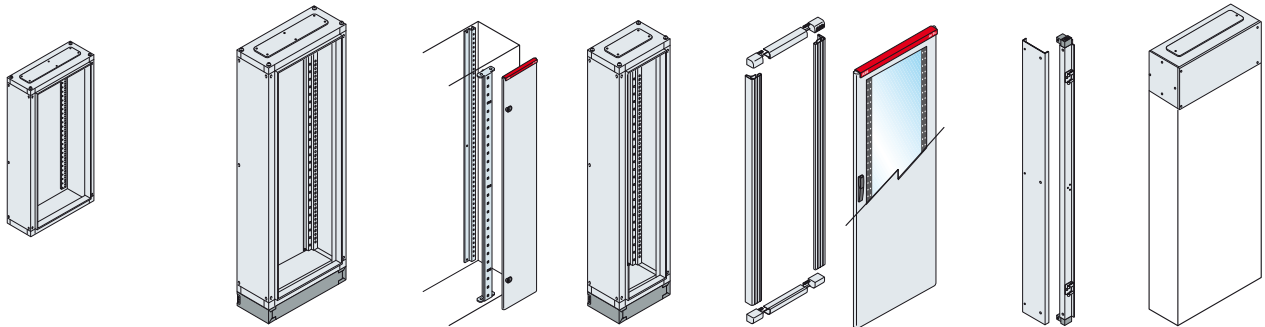

Wall structures			Floor structures			Internal cable container	Additional cable container	Front covers		Removable side panels	Cable connection box
Functional dimensions ⁽¹⁾ (mm)			Functional dimensions ⁽¹⁾ (mm)			Width	Width	IP31	IP43		
Height	Width	Depth	Height	Width	Depth	200mm	300mm				
600	600	165					•	•	•		
800	600	165					•	•	•		
1000	600	165					•	•	•		
1200	600	165					•	•	•		
			1400	600	195		•	•	•	•	•
			1600	600	195		•	•	•	•	•
			1800	600	195		•	•	•	•	•
			2000	600	195		•	•	•	•	•
			1400	800	195	•	•	•	•	•	•
			1600	800	195	•	•	•	•	•	•
			1800	800	195	•	•	•	•	•	•
			2000	800	195	•	•	•	•	•	•

⁽¹⁾ External dimensions available on page 8/6.

ArTu M

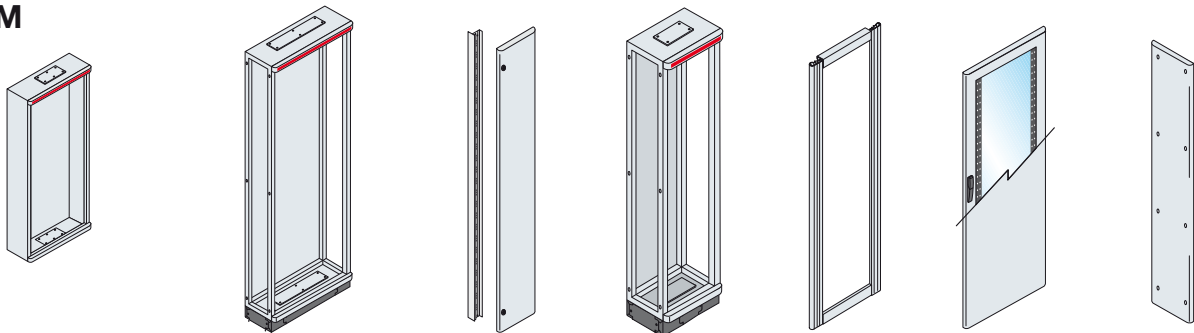

Wall structures			Floor structures			Internal cable container	Additional cable container	Front covers	Side covers
Functional dimensions ⁽¹⁾ (mm)			Functional dimensions ⁽¹⁾ (mm)			Width	Width	IP31	IP65
Height	Width	Depth	Height	Width	Depth		300mm		IP65
600	600	115							•
	600	115							•
800	600	165							•
1000	600	165							•
1200	600	165							•
			1400	600	195		•	•	•
			1600	600	195		•	•	•
				800	195	•	•	•	•
			1800	600	195		•	•	•
				800	195	•	•	•	•
			2000	600	195		•	•	•
				800	195	•	•	•	•

⁽¹⁾ External dimensions available on page 8/10.

Presentation of the range

Composition of the series

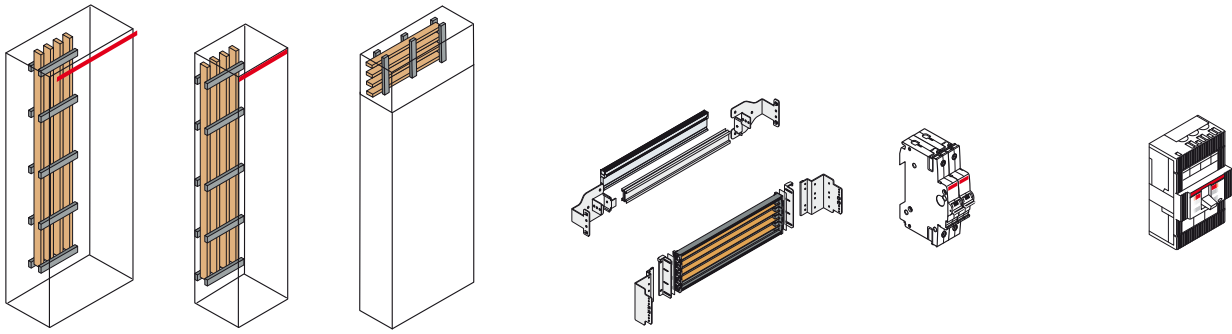

Busbar distribution system			Unifix distribution system		System Pro M modular apparatus	Tmax moulded-case circuit-breakers		
Vert. back	Vert. cable container	Horiz. box	L Series	H Series		T1-T2-T3 ≤250A	T4-T5-T6 ≤800A	XT1-XT3 250A
•	•		•	•	•	•		•
•	•		•	•	•	•		•
•	•		•	•	•	•		•
•	•		•	•	•	•		•
•	•	•	•	•	•	•	•	•
•	•	•	•	•	•	•	•	•
•	•	•	•	•	•	•	•	•
•	•	•	•	•	•	•	•	•
•	•	•	•	•	•	•	•	•
•	•	•	•	•	•	•	•	•
•	•	•	•	•	•	•	•	•
•	•	•	•	•	•	•	•	•
•	•	•	•	•	•	•	•	•
•	•	•	•	•	•	•	•	•
•	•	•	•	•	•	•	•	•
•	•	•	•	•	•	•	•	•
•	•	•	•	•	•	•	•	•

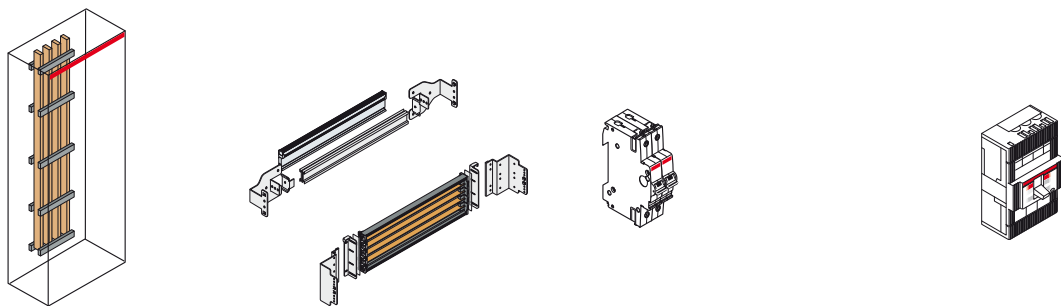

Busbar distribution system	Unifix distribution system		System Pro M modular apparatus	Tmax moulded-case circuit-breakers			
Vert. cable container	L Series	H Series		T1-T2 160A	T3 250A	T4-T5-T6 630A	XT1-XT3 250A
	•		•	•			•
	•		•	•			•
	•		•	•		•	•
	•		•	•		•	•
•	•	•	•	•	•	•	•
•	•	•	•	•	•	•	•
•	•	•	•	•	•	•	•
•	•	•	•	•	•	•	•
•	•	•	•	•	•	•	•
•	•	•	•	•	•	•	•
•	•	•	•	•	•	•	•
•	•	•	•	•	•	•	•
•	•	•	•	•	•	•	•
•	•	•	•	•	•	•	•
•	•	•	•	•	•	•	•
•	•	•	•	•	•	•	•
•	•	•	•	•	•	•	•
•	•	•	•	•	•	•	•
•	•	•	•	•	•	•	•

Presentation of the range

Composition of the series

ArTu K

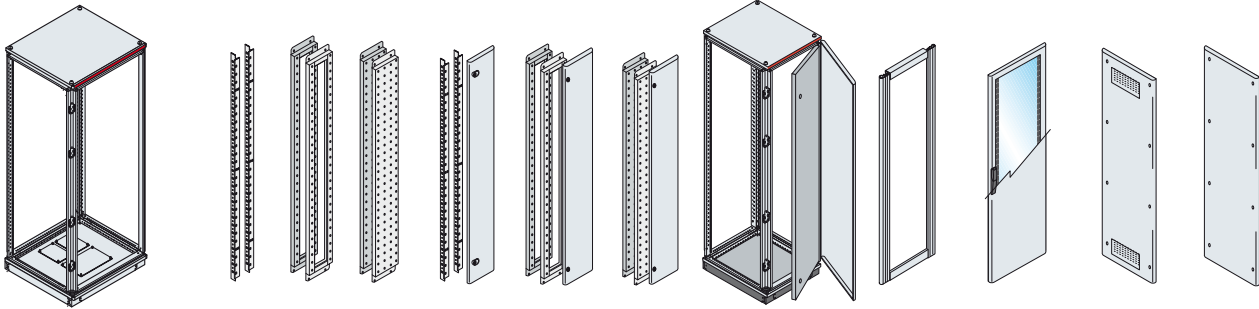

Functional dimensions ⁽¹⁾ (mm)			Functional frames			Internal cable container			Addit. cable container	Front coverings		Side coverings	
Height	Width	Depth	reduced	open	closed	with reduced frames	for frames open	for frames closed	Width 300mm	IP31/41	IP65	IP31/41	IP65
1600	600	150	•						•	•	•	•	
	800	150	•			•			•	•	•	•	
	390	225	•	•					•	•	•	•	
	390	300	•	•					•	•	•	•	
	390	500	•	•	•				•	•	•	•	
	390	700	•	•	•				•	•	•	•	
	390	900	•	•	•				•	•	•	•	
1800	600	150	•						•	•	•	•	
	600	225	•	•					•	•	•	•	
	600	300	•	•					•	•	•	•	
	600	500	•	•	•				•	•	•	•	
	600	700	•	•	•				•	•	•	•	
	600	900	•	•	•				•	•	•	•	
	800	150	•			•			•	•	•	•	
	800	225	•	•		•			•	•	•	•	
	800	300	•	•		•			•	•	•	•	
	800	500	•	•	•		•	•	•	•	•	•	•
2000	800	700	•	•	•		•	•	•	•	•	•	•
	800	900	•	•	•		•	•	•	•	•	•	•
	800	900	•	•	•		•	•	•	•	•	•	•

External dimensions available on page 8/14.

Gemini

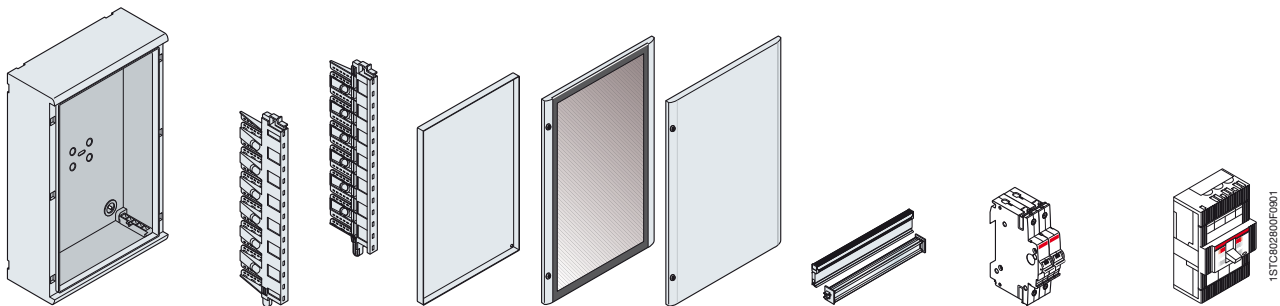

Functional dimensions ⁽¹⁾ (mm)			Functional frames	Front coverings			Unifix L distribution system	System Pro M modular apparatus	Tmax moulded-case circuit-breakers T1...T5 630A
Height	Width	Depth		counterdoor IP40	glass door IP66	blind door IP66			
300	250	180	•	•	•	•	•	•	
450	375	230	•	•	•	•	•	•	
600	375	230	•	•	•	•	•	•	
600	500	230	•	•	•	•	•	•	
750	500	330	•	•	•	•	•	•	
900	750	300	•	•	•	•	•	•	

External dimensions available on page 8/14.

Presentation of the range

Composition of the series

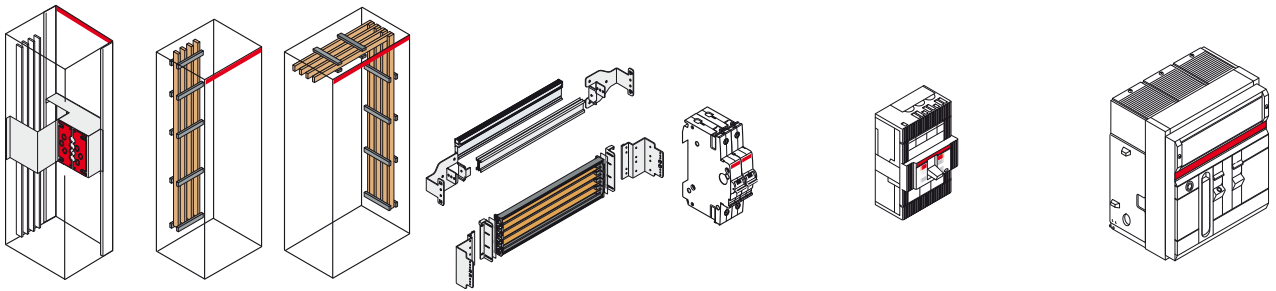

1STC62003F0901



Segregation	Busbar distribution system			Unifix distribution system		System Pro M modular apparatus	Tmax moulded-case circuit-breakers			Emax air circuit-breakers		
	Form 2/3/4	Vert. back	Vert. side	Horiz.	L Series		H Series	T1...T6	T7	XT1...XT4 250A	X1	E1-E2-E3 ≤3200A
		•	•		•	•	•	•	•			
		•	•		•	•	•	•	•			
		•	•		•	•	•	•	•			
		•	•	•	•	•	•	•	•			
•	•	•	•	•	•	•	•	•	•	•		
•	•	•	•	•	•	•	•	•	•	•		
•	•	•	•	•	•	•	•	•	•	•		
		•	•		•	•	•	•	•			
		•	•	•	•	•	•	•	•			
		•	•	•	•	•	•	•	•			
		•	•	•	•	•	•	•	•			
		•	•	•	•	•	•	•	•			
		•	•	•	•	•	•	•	•			
•	•	•	•	•	•	•	•	•	•	•		
•	•	•	•	•	•	•	•	•	•	•		
•	•	•	•	•	•	•	•	•	•	•		•



Index

General.....	2/2
Selection of the structure.....	2/4
Kit for installing apparatus.....	2/6
Distribution system.....	2/8
Examples of configuration.....	2/10

Gemini switchboards

General

ABB SACE's Gemini range is revolutionizing the market of low voltage electric insulating switchboards. The reason for this is that it is the first switchboard made in thermoplastic material, to which the co-injection molding technique gives the same mechanical characteristics as polyester. This means that it is extremely sturdy, with its rigid covering and expanded internal core. Moreover, it contains no fiberglass, a material that with time rises to the surface, jeopardizing the functioning and safety of switchboards made in polyester with which it is usually mixed.

Gemini switchboards have IP66 degree of protection (IP30 with the door open and with the appropriate components installed) and a very high resistance to chemical and atmospheric agents. This is the reason why Gemini guarantees excellent performances even in particularly severe operating conditions.



In distribution and mixed applications, the Gemini switchboard is designed to be fitted with System pro *M* modular devices and Tmax moulded-case circuit breakers.



Gemini switchboards are made with co-injection, which ABB SACE is the first manufacturer in the electric field to use as a molding technique. This process obtains a "sandwich" of two materials with a compact external covering and an expanded core, guaranteeing the highest level of mechanical protection against impacts (IK10) without the need to add hardening substances.



The frame can be extracted to make wiring operations easier at the workbench.

Gemini switchboards

General

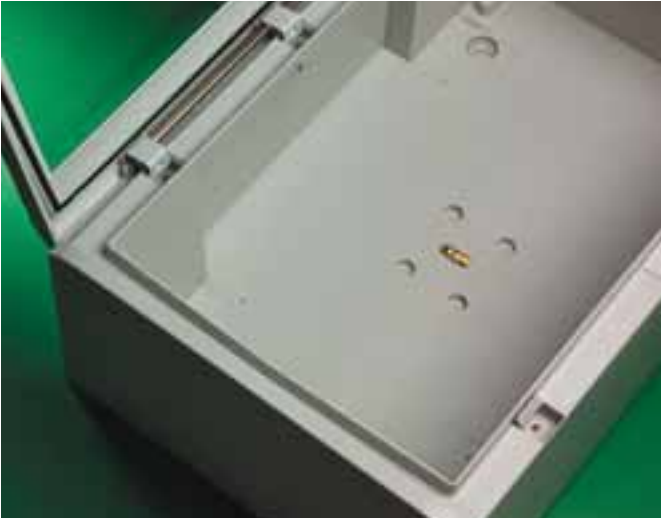

The special structure of the inner perimeter of the box ensures further protection against the penetration of water. The box is supplied with a spirit level.

The frame is the load-bearing element of the configuration: DIN rails, partial modular plates and the special Tmax mounting and cabling kits are snapped onto the uprights. All the components can be adjusted up to six levels of depth with 12.5 mm pitch and arranged in height with a standard installation pitch of 150, 225 and 300 mm and 75 mm distance between the rows.

Blank or drilled front panels are applied to protect the equipment and these can be hinged onto both sides; the cables are housed inside the vertical wiring duct integrated in the uprights according to an exclusive ABB patent.

Wiring is carried out by pulling out the frame and working from the front; the ergonomic grip and the standard feet and snap-on hooks supplied make it easy to insert it inside the switchboard after the job is finished.

To finish the job, the inner door can be mounted (reversible and in insulating material), guaranteeing IP30 degree of protection when the switchboard door is open.

No tools are needed unless the inner door is equipped with buttons, warning lights, etc.



Technical characteristics

Compliance with Standards	CEI EN 50298, CEI 23-48, CEI 23-49, IEC 60670, CEI EN 60439-1
Rated service voltage U_e	1000 V a.c. - 1500 V c.c.
Operating temperature	-25 °C ÷ +100 °C
Resistance to abnormal heat and fire	up to 750 °C
Degree of resistance to impacts IK	10
IP degree of protection	30 open door
	66 closed door
Recyclable	100%

Gemini switchboards

Selection of the structure

Structure

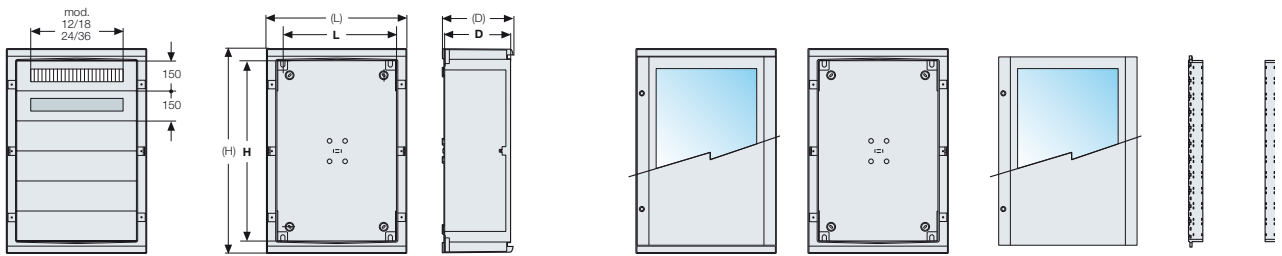

Size	N° of vertical mod. H=150mm	N° of instal- lable DIN modules	External dimensions			Functional dimensions			Complete switchboards		Door			
			(H) mm	(W) mm	(D) mm	H mm	W mm	D mm	Transparent	Opaque	Box	Transparent	Opaque	Uprights
1	2	24 (12x2)	400	335	210	300	250	180	1SL0211A00	1SL0201A00	1SL0221A00	1SL0241A00	1SL0231A00	1SL0283A00
2	3	54 (18x3)	550	460	260	450	375	230	1SL0212A00	1SL0202A00	1SL0222A00	1SL0242A00	1SL0232A00	1SL0284A00
3	4	72 (18x4)	700	460	260	600	375	230	1SL0213A00	1SL0203A00	1SL0223A00	1SL0243A00	1SL0233A00	1SL0285A00
4	4	96 (24x4)	700	590	260	600	500	230	1SL0214A00	1SL0204A00	1SL0224A00	1SL0244A00	1SL0234A00	1SL0285A00
5	5	120 (24x5)	855	590	360	750	500	330	1SL0215A00	1SL0205A00	1SL0225A00	1SL0245A00	1SL0235A00	1SL0286A00
6	6	216 (36x6)	1005	840	360	900	750	330	1SL0216A00	1SL0206A00	1SL0226A00	1SL0246A00	1SL0236A00	1SL0287A00

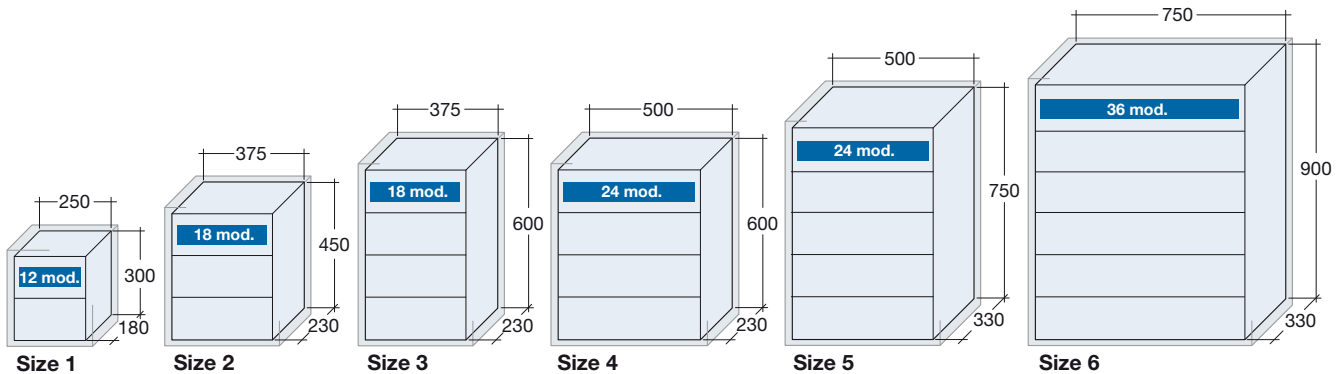

Gemini switchboards

Selection of the structure

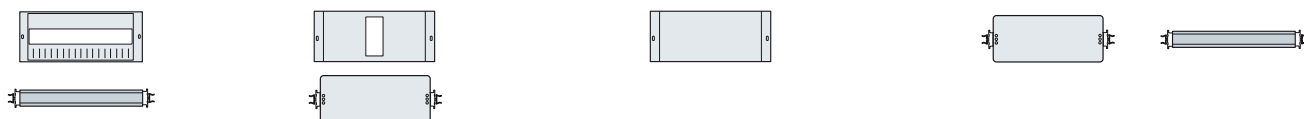

DIN rail kit DIN rail+drilled panel		Kit for Tmax plate+drilled panel		Blank panel			Modular plate		DIN rail
1 mod. H=150mm	1+1/2 mod. H=225mm	1 mod. H=150mm	2 mod. H=300mm	1/2 mod. H=75mm	1 mod. H=150mm	2 mod. H=300mm	1 mod. H=150mm	2 mod. H=300mm	
1SL0307A00	-	-	-	1SL0318A00	1SL0324A00	1SL0330A00	1SL0296A00	-	1SL0290A00
1SL0308A00	1SL0313A00	1SL0336A00	1SL0370A00	1SL0319A00	1SL0325A00	1SL0331A00	1SL0297A00	1SL0302A00	1SL0291A00
1SL0308A00	1SL0313A00	1SL0336A00	1SL0370A00	1SL0319A00	1SL0325A00	1SL0331A00	1SL0297A00	1SL0302A00	1SL0291A00
1SL0309A00	1SL0314A00	1SL0337A00	1SL0371A00	1SL0320A00	1SL0326A00	1SL0332A00	1SL0298A00	1SL0303A00	1SL0292A00
1SL0309A00	1SL0314A00	1SL0337A00	1SL0371A00	1SL0320A00	1SL0326A00	1SL0332A00	1SL0298A00	1SL0303A00	1SL0292A00
1SL0310A00	1SL0315A00	1SL0338A00	1SL0372A00	1SL0321A00	1SL0327A00	1SL0333A00	1SL0299A00	1SL0304A00	1SL0293A00

Suggestion for installation of Tmax moulded-case circuit breakers

The table indicates the type of installation required for the different versions of Tmax moulded-case circuit breakers in Gemini switchboards. Before carrying out wiring operations check compliance with Standards on the basis of the technical characteristics of the switchboard and circuit breaker (CEI 23-51 or CEI EN 60439-1).

Size	Installation	Tmax T1	Tmax T2	Tmax T3	Tmax T4	Tmax T5
1	D	•	•	•		
	O1	•	•			
	T	•	•	•	• (3)	• (3)
2	D	•	•	•		
	K1	•	• (1)			
	K2	•	• (2)	•		
	O1	•	•	•	• (4)	
	O2	•	•	•	•	• (3)
T	•	•	•	•	•	
3	D	•	•	•		
	K1	•	• (1)			
	K2	•	• (2)	•		
	O1	•	•	•	• (4)	
	O2	•	•	•	•	• (3)
T	•	•	•	•	•	
4	D	•	•	•		
	K1	•	• (1)			
	K2	•	• (2)	•		
	O1	•	•	•	• (4)	
	O2	•	•	•	•	•
T	•	•	•	•	•	
5	D	•	•	•		
	K1	•	• (1)			
	K2	•	• (2)	•		
	O1	•	•	•	• (4)	
	O2	•	•	•	•	•
T	•	•	•	•	•	
6	D	•	•	•		
	K1	•	• (1)			
	K2	•	• (2)	•		
	O1	•	•	•	• (4)	
	O2	•	•	•	•	•
T	•	•	•	•	•	

Caption

- D, installation on DIN rail
- K1, installation with Tmax kit H = 150 (holes made)
- K2, installation with Tmax kit H = 300 (holes made)
- O1, installation on modular plate (1 module, H = 150 mm)
- O2, installation on modular plate (2 modules, H = 300 mm)
- T, installation on total base plate
- • (1), Tmax T2 3 poles (with or without residual current release) and Tmax T2 4 poles (without residual current release)
- • (2), Tmax T2 4 poles (with residual current release)
- • (3), only version without residual current release
- • (4), only version with 3 poles

Gemini switchboards

Kit for installing apparatus

Horizontal installation

Kit for Tmax with pre-drilled holes

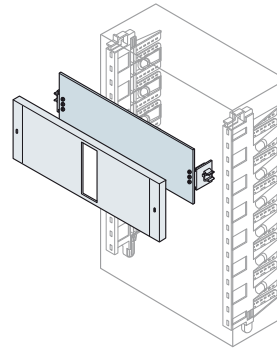

Fixed circuit-breaker with front terminals	N° poles	Dimensions H (mm)	Size		
			2/3	4/5	6
Tmax T1	3-4	150	1SL0336A00	1SL0337A00	1SL0338A00
Tmax T2	3-4	150	1SL0336A00	1SL0337A00	1SL0338A00
Tmax T2+res. cur.	3	300	1SL0370A00	1SL0371A00	1SL0372A00
Tmax T3	3-4	300	1SL0370A00	1SL0371A00	1SL0372A00

Vertical installation

Installation on DIN rail

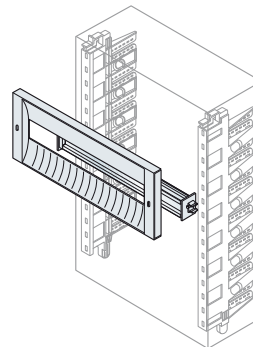

Fixed circuit-breaker with front terminals	N° poles	Dimensions H (mm)	Size			
			1	2/3	4/5	6
System Pro M compact modular apparatus		150	1SL0307A00	1SL0308A00	1SL0309A00	1SL0310A00
		225		1SL0313A00	1SL0314A00	1SL0315A00
Tmax T1-T2-T3	3-4	225		1SL0313A00	1SL0314A00	1SL0315A00

Gemini switchboards

Kit for installing apparatus

Wiring ducts

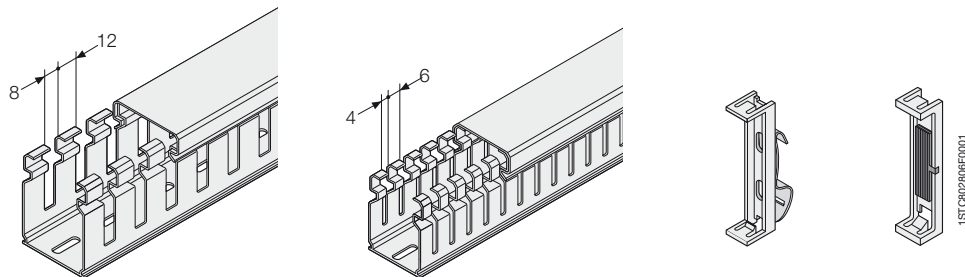

Wiring ducts

Fix-O-rapid

Base (mm)	H (mm)
15	17
	30
	40
25	60
	80
	100
40	30
	40
	60
	80
60	100
	30
	40
	60
80	80
	100
	40
	60
100	80
	100
	40
120	80
	100

8-12 mm slots	4-6 mm slots
05 019	05 119
05 033	05 133
05 043	05 143
05 063	05 163
05 083	05 183
05 094	05 194
05 035	05 135
05 045	05 145
05 065	05 165
05 085	05 185
05 095	05 195
05 037	05 137
05 047	05 147
05 067	05 167
05 087	05 187
05 096	05 196
05 049	05 149
05 069	05 169
05 089	05 189
05 097	05 197
05 051	05 151
05 071	05 171
05 091	05 191
05 098	05 198
05 053	05 153
05 093	05 193
05 099	05 199

Rapid snap-on bases for DIN rail	Rapid snap-on bases for plate
-	-
05 250	05 270
05 252	05 272
05 254	05 274
05 256	05 276
05 258	05 278
05 260	05 280
05 262	05 282

Gemini switchboards

Distribution systems

Modular dividers

Single-pole

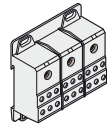
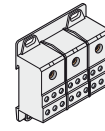
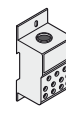
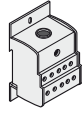
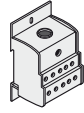

Code		AD1076	AD1080 ⁽¹⁾	AD1007	AD1081 ⁽²⁾	AD1030	AD1031	AD1075	AD1006
In (A)		125	125	160	160	250	400	125	160
Icw (kA)		4.2	10	11	10	21	21	4.2	
Version	poli	1	1	1	1	1	1	3	3
Installation		DIN35/plate	DIN35/plate	DIN35/plate	DIN35/plate	DIN35/plate	DIN35/plate	DIN35/plate	DIN35/plate
Power supply Ø cable (mm ²)	min.	10	6	16	10	35	95	10	16
	max	35	35	70	70	120	185	35	70
N° outgoing feeder (mm ²)	2.5÷10								
	Ø cable								
	2.5÷16	10	6	10	6	5	5	6	6
	2.5÷25					2	2		
	2.5÷35								
Dimensions HxWxD (mm)		71x45x42.5	75x25x47	71x45x42.5	92x35x49	96x45x49	96x45x49	80x71.5x42.5	80x71.5x42.5
N° DIN modules		2.5	1.5	2.5	2	3	3	4.5	4.5
Rated service voltage Ue (V)		690	500	690	500	500	500	690	690
Degree of protection	IP	20	20	20	20	20	20	20	20

Three-poles

Four-poles

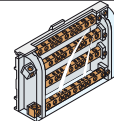
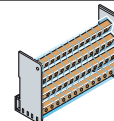
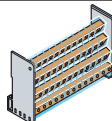
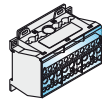

Code		AD1004	AD1028	AD1029	AD1027
In (A)		125	125	125	160
Icw (kA)		10	4.2	4.2	6
Version	poles	4	4	4	4
Installation		DIN35/plate	DIN35/plate	DIN35/plate	DIN35
Power supply Ø cable (mm ²)	min.	6	6	6	10
	max	35	25 with cable terminal 35 without cable terminal	25 with cable terminal 35 without cable terminal	50
N° outgoing feeder (mm ²)	Ø cable				
	5 holes/phase Ø1.5÷16		2xØ6÷25 + cable terminal	2xØ6÷25 + cable terminal	8xØ2.5÷16
	2 holes/phase Ø1.5÷16		2xØ6÷35 no cable terminal	2xØ6÷35 no cable terminal	3xØ6÷35
	6 holes/neutral Ø1.5÷16		9xØ6÷10	2xØ6÷16	
	4 holes/neutral Ø1.5÷6 ²			9xØ6÷10	
Dimensions HxWxD (mm)		45x75x98	89x93x48	126x93x48	90x160x50
N° DIN modules		5.5	5	7	9
Rated service voltage Ue (V)		500	690	690	500
Degree of protection	IP	20	20	20	20

⁽¹⁾ possibility of putting in parallel with AD1083 connections.

⁽²⁾ possibility of putting in parallel with comb type connections (not supplied).

Gemini switchboards

Distribution systems

Unifix L

Technical characteristics		Unifix L
Rated service voltage (U_n)		400V AC
Rated insulation voltage (U_i)		500V AC
Rated impulse withstand voltage (U_{imp})		6kV
Rated frequency		50/60Hz
Rated current (I_n)	central power supply	100A
	lateral power supply	80A
Rated short-time withstand current (I_{cw})		
Maximum peak current (I_{pk})		
Maximum installable circuit-breaker size		100A
Conditioned short-circuit current (I_{cs})	Tmax T1	
	Tmax T2 N, S ⁽¹⁾	
	Tmax T3	
With circuit-breaker	S200	6kA-400V
	S200 H	10kA-400V
	S200 P	25kA-400V
Degree of protection		IP20
Characteristics of the insulating material		Self-extinguishing thermoplastic V1 (UL94)
Characteristics of the conductor material		Electrolytic copper
Width (N° modules/mm)		12/400
		18/500
		24/600
		36/800

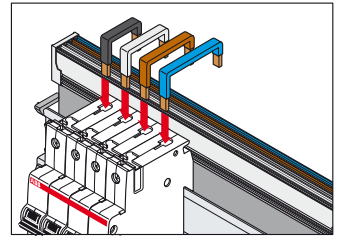

Connections (L1-L2-L3-N) for System Pro M modular apparatus..

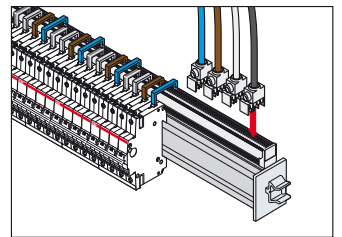

Power supply of the busbar with 100A feeder module without cable. Terminal capacity 35mm².

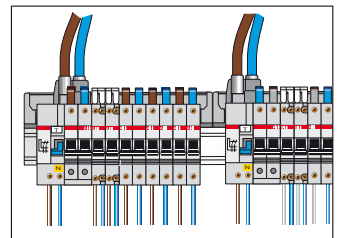

Direct power supply of the busbars by means of feeder module.

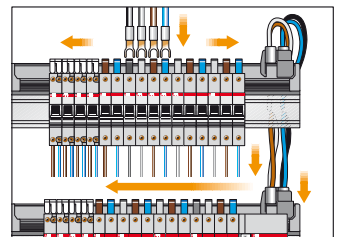

Power supply by means of modules and cables in parallel.

Table for selecting connections according to the circuit-breaker

Circuit-breaker series	Unifix L
S941 - S951 - S971 DS941 - DS951 - DS971	ED3272 L1/N 40A ED3280 L2/N 40A ED3298 L3/N 40A
S200 - DS 200 F200 ≤ 63A	ED3033 L1 100A ED3041 L2 100A ED3058 L3 100A ED3066 N 100A
F660 - F670 - S280 (80-100A) E200 ≤ 100A - RS370 - F 200 80-100A (Unifix)	ED3132 Power supply L1/L2/L3/N - 350mm ED0026 Power supply L1/L2/L3/N - 1500mm ED0025 Power supply L1/L2/L3/N - 2500mm
MDRC - Various apparatus	ED3108 Power supply 2 cables L1/N 16A ED3116 Power supply 3 cables L1/L2/L3 16A ED3124 Power supply 4 cables L1/L2/L3/N 16A ED3355 Power supply 2 cables L1/N 40A ED3363 Power supply 3 cables L1/L2/L3 40A ED3371 Power supply 4 cables L1/L2/L3/N 71A

For the DDA locks, order the false module **ED2845** codes separately according to the size of the residual current lock.

Gemini switchboards

Examples of configuration

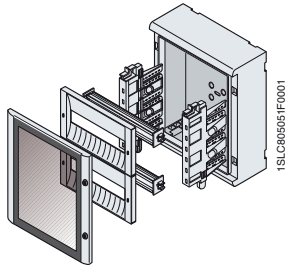

Gemini switchboards 12 mod. DIN dim.300x250x180 (400x335x210) mm (external hxwxh) IP66

Code	Description	Q.ty
1SL0211A00	Box + transparent door	1
1SL0283A00	No. 2 uprights	1
1SL0307A00	DIN rail kit (DIN rail + panel) H=150mm	2

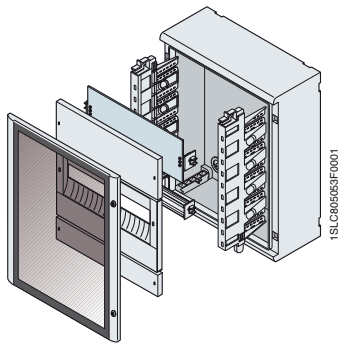

Gemini switchboards 18 mod. DIN dim.450x375x230 (550x460x260) mm (external hxwxh) IP66

Code	Description	Q.ty
1SL0212A00	Box + transparent door	1
1SL0284A00	No. 2 uprights	1
1SL0297A00	Modular plate 1 mod.DIN H=150mm	1
1SL0325A00	Blank panel 1 mod.DIN H=150mm	1
1SL0313A00	DIN rail kit (DIN rail+panel) 1+1/2 mod. H=225mm	1
1SL0319A00	Blank panel 1/2 mod. H=75mm	1
12863	Module covers	1

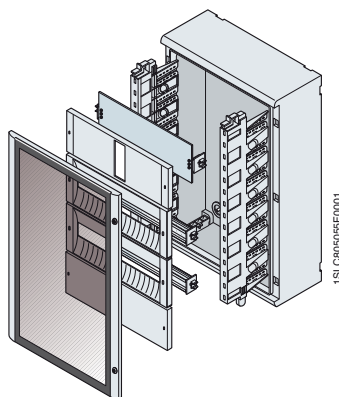

Gemini switchboards 18 mod. DIN dim.600x375x230 (700x460x260) mm (external hxwxh) IP66

Code	Description	Q.ty
1SL0213A00	Box + transparent door	1
1SL0285A00	No. 2 uprights	1
1SL0336A00	Kit for Tmax H=150mm	1
1SL0308A00	DIN rail kit (DIN rail + panel) 1 mod. H=150mm	2
1SL0291A00	DIN rail	1
1SL0325A00	Blank panel 1 mod. DIN H=150mm	1

Gemini switchboards

Examples of configuration

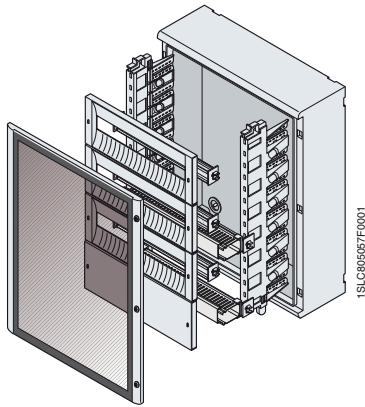

Gemini switchboards 24 mod. DIN dim.600x500x230 (700x590x260) mm (external hxwxh) IP66

Code	Description	Q.ty
1SL0214A00	Box + transparent door	1
1SL0285A00	No. 2 uprights	1
1SL0309A00	DIN rail kit (DIN rail+panel) 1 mod. H=150mm	3
1SL0326A00	Blank panel 1 mod. H=150mm	1
1SL0355A00	Wiring kit (Fix-O-rapid+wiring duct 25x60mm)	2
1SL0292A00	DIN rail	1
12863	Module covers	1

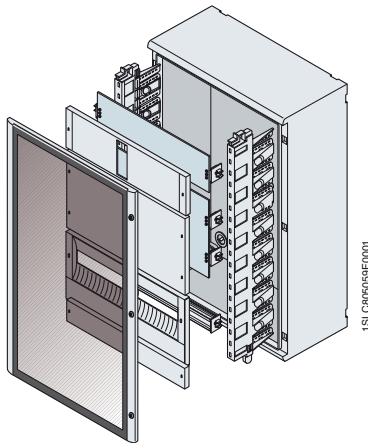

Gemini switchboards 24 mod. DIN dim.750x500x330 (855x590x360) mm (external hxwxh) IP66

Code	Description	Q.ty
1SL0215A00	Box + transparent door	1
1SL0286A00	No. 2 uprights	1
1SL0337A00	Kit for Tmax H=150mm	1
1SL0303A00	Modular plate H=300mm	1
1SL0332A00	Blank panel H=300mm	1
1SL0314A00	DIN rail kit (DIN rail+panel) 1+1/2 mod. H=225mm	1
1SL0320A00	Front blind panel 1/2 mod. H=75mm	1
12863	Module covers	1

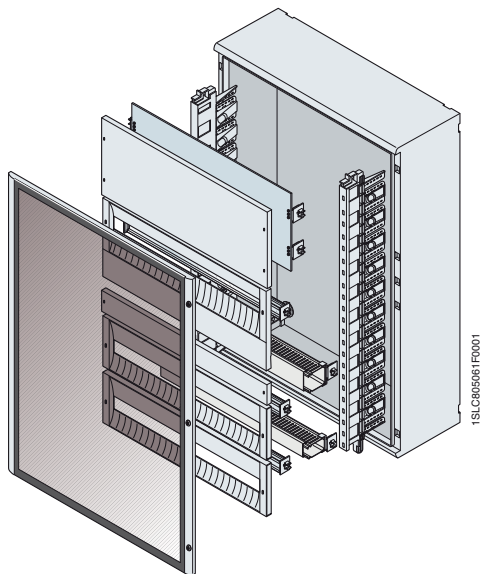

Gemini switchboard 36 mod. DIN dim.900x750x330 (1005x840x360) mm (external hxwxh) IP66

Code	Description	Q.ty
1SL0216A00	Box + transparent door	1
1SL0287A00	No. 2 uprights	1
1SL0304A00	Modular plate H=300mm	1
1SL0333A00	Blank panel H=300mm	1
1SL0315A00	DIN rail kit (DIN rail + panel) 1+1/2 mod. H=225mm	1
1SL0321A00	Blank panel 1/2 mod. H=75mm	1
1SL0310A00	DIN rail kit (DIN rail+panel) 1 mod. H=150mm	2
1SL0356A00	Wiring kit (Fix-O-rapid+wiring duct 25x60mm)	1
1SL0363A00	Wiring kit (Fix-O-rapid+wiring duct 40x60mm)	1



Index

General.....	3/2
Selection of the structure.....	3/4
Kit for installing apparatus.....	3/6
Distribution systems.....	3/10
Exemples of configuration.....	3/17

ArTu L modular structures

General

The ArTu L range is composed of structures consisting of modular kits which can be built up in different combinations able to cover applications of terminal distribution switchgear, both wall-mounted up to 250 A and floor-standing up to 800 A. The overall dimensions are reduced thanks to the depth of just 200 mm for the former and 240 mm for the latter. Both versions can be placed side-by-side with other structures and with cable risers with a width of 300 mm.

Modular apparatus of the System pro *M* series, moulded-case * T series up to T6 800 A, XT series up to XT4, (fixed version with front terminals) circuit-breakers are housed inside the ArTu L switchgear, with a capacity of 24 or 36 modules per row.

Apart from in the traditional plain and pre-drilled versions with 200 mm height, the modular panels are also available in the 150 mm height, which allows optimisation of the space available.



1STC802015F0001



1STC802015F0001

Cabling becomes simpler, thanks to the structure which is completely open: in fact, it is possible to conveniently carry out cabling horizontally on trestles inside the workshop or on the building site with the switchgear completely open and then only complete its assembly when cabling has been completed.



1STC802248F0001

Technical characteristics

	Wall-mounted D=204mm	Floor-standing D=240mm
Compliance with Standards	CEI EN 60439-1/IEC 61439-1-2	
Rated service voltage U_e	up to 690 V	
Rated insulation voltage U_i	up to 1000 V	
Rated frequency	50-60 Hz	
Rated impulse withstand voltage U_{imp}	6 kV	8 kV
Rated current I_n	up to 250 A	up to 800 A
Rated short-time short-circuit withstand current I_{cw}	up to 25 kA	up to 35 kA
Rated short-circuit peak current I_{pk}	up to 52.5 kA	up to 74 kA
IP degree of protection	31 without door 43 with door	31 without door 43 with door

ArTu L modular structures

General

It is possible to use the rapid Unifix (H and L) cabling system. Furthermore, the kit for fixing the circuit-breakers further simplifies the job, thanks to the practical rapid snap-on hooking up system and the standardised small items.



3

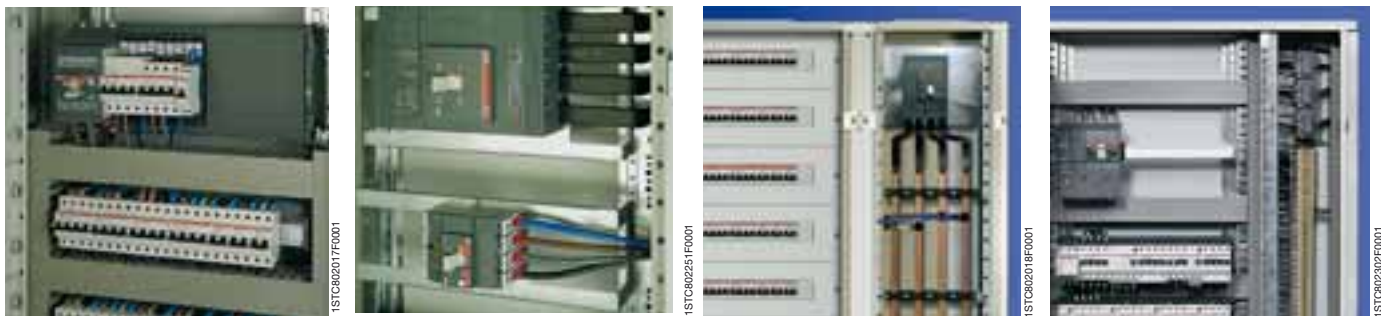

The 400 and 800A busbar system with shaped section, with prefabricated connections between circuit-breakers and busbars placed in the various situations can be used. It is always possible to use the traditional flat busbars for capacities up to 630A. The degree of protection goes from IP31, for the versions without door, up to IP43 for the versions with door.

Lateral access is guaranteed, as is the possibility of mounting the vertical wiring duct both on the right, on the left and horizontally.

An accessory box is available, to be placed above the switchgear roof, which increases the space available for the incoming cables and, together with the distribution frame, makes distribution simpler. The maximum form of segregation, which can be obtained, is type 2.

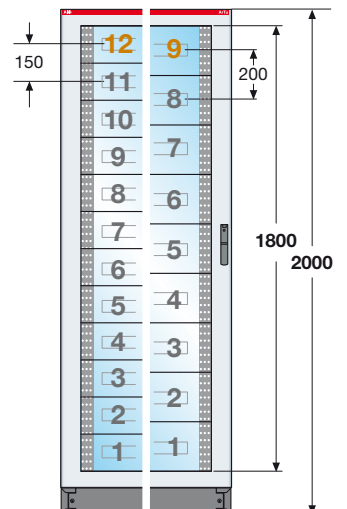

ArTu L modular structures

Selection of the structure

Structures

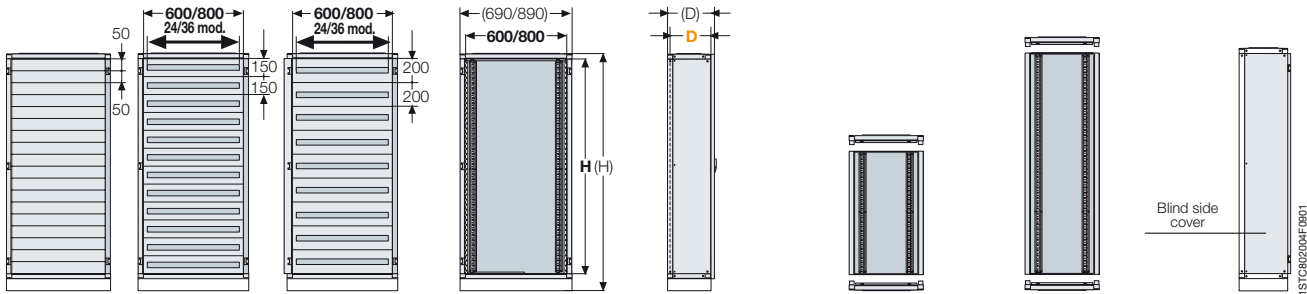

No. vert. mod. H=100mm	No. DIN modules installable		External overall dimensions ⁽¹⁾			Functional dimensions ⁽²⁾			Wall-mounted back of structure ⁽³⁾	Floor-standing back of structure	Side cover	
	DIN panel 24/36 modules H=150mm	DIN panel 24/36 modules H=200mm	(H)	(W)	(D)	H	W	D ⁽⁴⁾				
6	96 (24x4)	72 (24x3)	650	690	204	600	600	165	Including roof and base	Including roof and base	Blind	
8	120 (24x5)	96 (24x4)	850			SL0600			MC0600			
10	144 (24x6)	120 (24x5)	1050			SL0800			MC0800			
12	192 (24x8)	144 (24x6)	1250			SL1000			MC1000			
14	216 (24x9)	168 (24x7)	1550	690	240	1400	600	195	SL1200	MC1200	SL1400	MC1400
16	240 (24x10)	192 (24x8)	1750			SL1600			MC1600	SL1800	MC1800	
18	288 (24x12)	216 (24x9)	1950			SL2000			MC2000	SL1408	MC1400	
20	312 (24x13)	240 (24x10)	2150			SL1608			MC1600	SL1808	MC1800	
14	324 (36x9)	252 (36x7)	1550	890	240	1400	800	195	SL2008	MC2000	SL1608	MC1600
16	360 (36x10)	288 (36x8)	1750			SL1808			MC1800	SL1808	MC1800	
18	432 (36x12)	324 (36x9)	1950			SL2008			MC2000	SL2008	MC2000	
20	468 (36x13)	360 (36x10)	2150			SL2008			MC2000	SL2008	MC2000	

Additional cable container

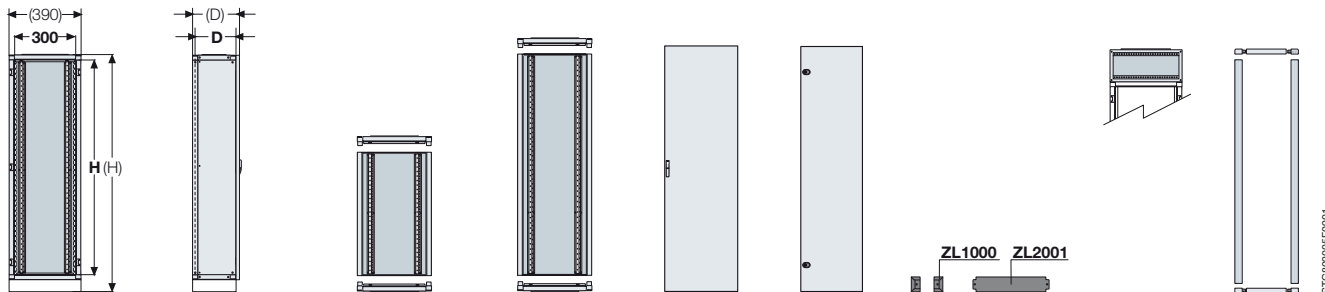

External overall dimensions ⁽¹⁾			Functional dimensions ⁽²⁾			Wall-mounted cable container ⁽³⁾	Floor-mounted cable container	Front door IP43	Internal doors	Base strip		Connection box	Finishing section IP31			
(H)	(W)	(D)	H	W	D ⁽⁴⁾					Including roof and base	Including roof and base			Plain door	Plain door	Angles
650	390	204	600	300	165	Including roof and base	Including roof and base	Plain door	Plain door	Angles	Flanges	Roof	See page 9/17			
850			VC0600			VC0800	PC0602									
1050			VC1000			VC1000	PC1002									
1250			VC1200			VC1200	PC1202									
1550	1400	390	300	195	VC1400	VC1600	VC1800	VC2000	PO1431	PO1631	PO1831	PO2031		ZL1000	ZL2001	RC2000
1750	1600				PC1402	PC1602	PC1802	PC2002								
1950	1800				PC1602	PC1802	PC1802	PC2002								
2150	2000				PC1802	PC2002	PC2002	PC2002								

- (1) The external overall dimensions of floor-mounted ArTu L switchgear include the palletisable base strip h=100mm (angle and flanges to be ordered separately).
- (2) The functional dimensions represent the useful space for installing the apparatus.
- (3) The wall-mounted structures cannot be superimposed.
- (4) In this catalogue, reference is always made to the 204/240mm depth corresponding respectively to the overall dimensions with front door. The useful dimensions between panel and back of the structure are 165/195 mm.

ArTu L modular structures

Selection of the structure

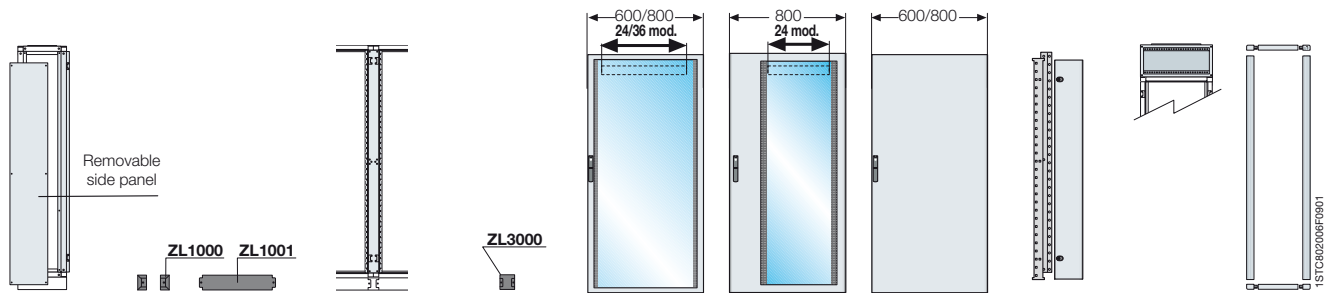

Side cover	Base strip		Intermediate uprights	Base strip	IP43 front doors			Internal cable container	Connection box	IP31 finishing section
With removable panel	Angles	Flanges	For side-by-side positioning	Angle for side-by-side structures	Glass door 24/36 mod.	Glass door 24 mod.+ int cable container	Blind door 24/36 mod.		Roof	
			MI0600		PV0600		PC0601			
			MI0800		PV0800		PC0801			
			MI1000		PV1000		PC1001			
			MI1200		PV1200		PC1201			
LF1400	ZL1000	ZL1001	MI1400	ZL3000	PV1400		PC1401		RC1000	see page 9/17
LF1600			MI1600		PV1600		PC1601			
LF1800			MI1800		PV1800		PC1801			
LF2000			MI2000		PV2000		PC2001			
LF1400	ZL1000	ZL1101	MI1400	ZL3000	PV1436	PV1424	PC1436	VC1425		
LF1600			MI1600		PV1636	PV1624	PC1636	VC1625		
LF1800			MI1800		PV1836	PV1824	PC1836	VC1825		
LF2000			MI2000		PV2036	PV2024	PC2035	VC2025		

Recommended solutions for installation of the apparatus

Apparecchiature	Tipi di struttura/installazione						
	Wall structures			Floor structures			Connection box
	Vertical on DIN rail	Vertical	Horizontal	Vertical on DIN rail	Vertical	Horizontal	Horizontal
Pro M System modular apparatus	•			•			
OT					•	•	
OESA					•		
OETL					•		
Tmax T1 3/4 poles - fixed / front terminals	•	•	•	•	•	•	
Tmax T1 4 poles - fixed / front terminals + diff. mod.			•		•	•	
Tmax T2 3/4 poles - fixed / front terminals	•	•	•	•	•	•	
Tmax T2 4 poles - fixed / front terminals + diff. mod.			•		•	•	
Tmax T3 3/4 poles - fixed / front terminals	•	•	•	•	•	•	
Tmax T3 4 poles - fixed / front terminals + diff. mod.		•			•	•	
Tmax T3 3/4 poles - fixed / front terminals + divider					•	•	
Tmax T4 3/4 poles - fixed / front terminals					•	•	
Tmax T4 4 poles - fixed / front terminals + diff. mod.					•	•	
Tmax T5 3/4 poles - fixed / front terminals					•	•	
Tmax T5 4 poles - fixed / front terminals + diff. mod.					•	•	
Tmax T6 3/4 poles - fixed / front terminals					•	•	
Tmax T6 4 poles - fixed / front terminals					•	•	
Side-by-side Tmax kits					•	•	
Tmax XT1 3/4 poles - fixed / front terminals	•	•	•	•	•	•	
Tmax XT1 4 poles - fixed / front terminals + diff. mod.		•	•		•	•	
Tmax XT2 3/4 poles - fixed / front terminals			•			•	
Tmax XT2 4 poles - fixed / front terminals + diff. mod.			•			•	
Tmax XT3 3/4 poles - fixed / front terminals	•	•	•	•	•	•	
Tmax XT3 4 poles - fixed / front terminals + diff. mod.	•	•	•	•	•	•	
Tmax XT4 3/4 poles - fixed / front terminals		•	•		•	•	
Tmax XT4 4 poles - fixed / front terminals + diff. mod.		•	•		•	•	
Side-by-side Tmax XT kits					•	•	
Busbars with snapped section		•			•		•
Linear busbar holder		•			•		•
Scaled busbar holder					•		•
Flat busbar		•			•		•
Linear busbar holder		•			•		•
Scaled busbar holder			•		•		•
Unifix L						•	
Unifix H						•	

(•) Can also be installed in the additional cable container.

(■) Can only be installed in the additional cable container.

ArTu L modular structures

Kit for installing apparatus

Kit for System Pro M, ≤160 OT modular apparatus, Tmax T1-T2-T3, XT1 and XT3, and supports for Unifix H

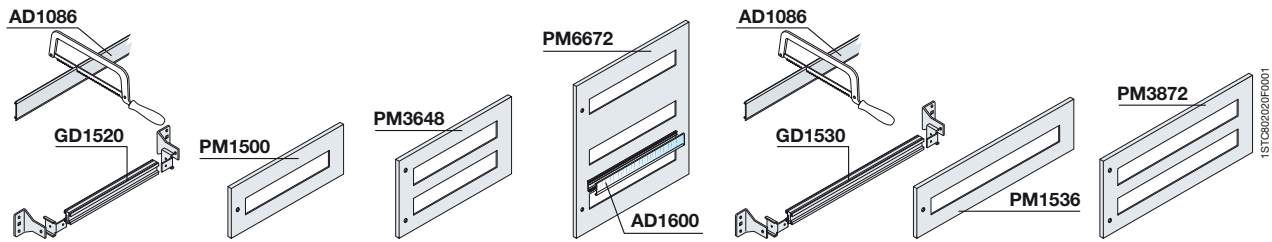

H (mm)	W=300mm		W=600mm			W=800mm			
	DIN rail kit 12 DIN mod.	Panel 1 DIN row 12 DIN mod.	DIN rail kit 24 DIN mod.	Panel 1 DIN row 24 DIN mod.	Panel 2 DIN rows 48 DIN mod.	Panel 3 DIN rows 72 DIN mod.	DIN rail kit 36 DIN mod.	Panel 1 DIN rows 36 DIN mod.	Panel 2 DIN rows 72 DIN mod.

Standard aluminium version

150 ⁽¹⁾			GD1520	PM1500			GD1530	PM1536	
200	GD1512	PM2612	GD1520	PM2624			GD1530	PM2836	
300 ⁽²⁾			GD1520	PM2312			GD1530	PM2315	
300			2x GD1520		PM3648 ⁽¹⁾		2x GD1530		PM3872 ⁽¹⁾
600			3x GD1520			PM6672			

Unifix H fixing brackets

300			AD1097	PM3624			AD1097	PM3836	
-----	--	--	--------	--------	--	--	--------	--------	--

⁽¹⁾ Only for modular System Pro M

⁽²⁾ Version for Tmax with differential module underplated RC 221/222.

Completion items for installation on DIN rail

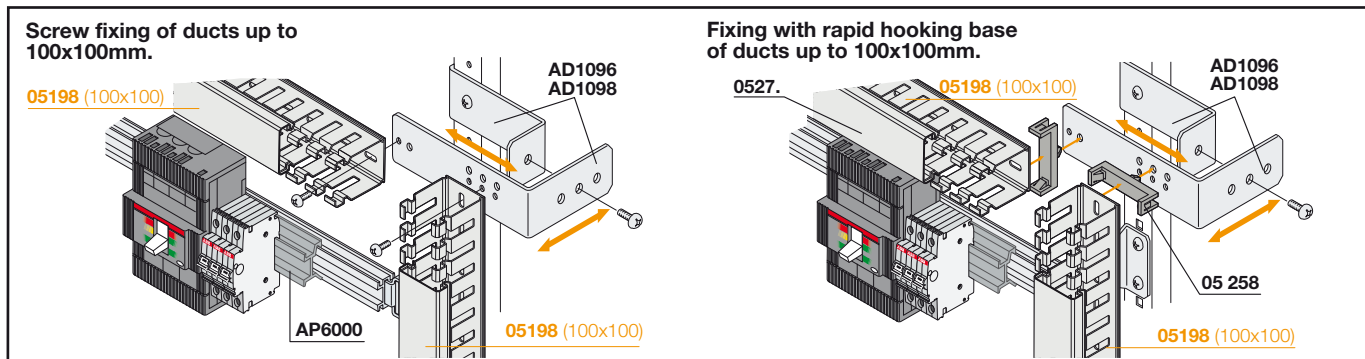

Supports for horizontal wiring duct

Code	Description
AD1096	Support for horizontal/vertical wall-mounted wiring duct
AD1098	Support for horizontal/vertical floor-mounted wiring duct

Allows assembly of the cabling wiring duct horizontally and vertically up to 100x100mm (in the case of installation in floor-mounted structure with removable side panel LF... the vertical wiring duct has maximum dimensions of 100x80mm hxb). The support AD1098 has compensation drillings as the height and width of the wiring duct varies. The accessory is also prepared with ø7mm holes for assembly of the ABB wiring duct by means of the Fix-O-rapid hook.

For Isomax kits, please see page 9/83.

Depth adapter

Code	Description
AP6000	Depth adapter W=600mm for side-by-side Pro M - Tmax T1-T2-T3-XT1- XT3

DIN cut-out hole covers

Code	Description
AD1086	Hole covering strip DIN W=2000mm - grey RAL 7035
AD1088	Hole covering strip DIN 24 modules - grey RAL 7035
AD1089	Hole covering strip DIN 36 modules - grey RAL 7035

Tmax XT Flangers for DIN-Rail mounting

Code	Description
AD3301	XT1 3P Flanger for DIN-Rail mounting
AD3302	XT1 4P Flanger for DIN-Rail mounting
AD3303	XT3 3P Flanger for DIN-Rail mounting
AD3304	XT3 4P Flanger for DIN-Rail mounting

Already supplied in the DIN-Rail mounting kit for breakers in MCCBs catalogue 1SDC210033D0901

ArTu L modular structures

Kit for installing apparatus

Horizontal installation

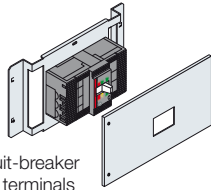

Circuit-breaker front terminals	No. poles	Dimensions H (mm)	Fixed			
			Wall-mounted structures		Floor-mounted structures	
			Structure 24 DIN mod. W=600mm		Structure 24 DIN mod. W=600mm	Structure 36 DIN mod. W=800mm
Tmax T1	3-4	200	LK1000		LK1000	LK1100
Tmax T1 CB + diff. mod.	4	200	LK1004 ⁽¹⁾		LK1004 ⁽¹⁾	LK1104 ⁽¹⁾
Tmax T2	3-4	200	LK2000		LK2000	LK2100
Tmax T2 CB + diff. mod.	4	200	LK2004		LK2004	LK2104
Tmax T3	3-4	200	LK3000		LK3000	LK3110
Tmax T3 CB + diff. mod.	4	300	LK3004		LK3004	LK3104
Tmax T3 CB + distr. frame	3-4	200			LK3301	
Tmax T4	3-4	200			LK4003	LK4103
Tmax T4 CB + diff. mod.	4	200			LK4004	LK4104
Tmax T5	3-4	300			LK5003	LK5103
Tmax T5 CB + diff. mod.	4	300			LK5004	LK5104
Tmax XT1	3 ⁽²⁾ /4	200	LX1000		LX1000	LX1100
Tmax XT1 CB + diff. mod.	4	200	LX1005		LX1005	LX1104
Tmax XT2	3 ⁽²⁾ /4	200	LX2000		LX2000	
Tmax XT2 CB + diff. mod.	4	200	LX2004		LX2004	
Tmax XT3	3 ⁽²⁾ /4	200	LX3000		LX3000	LX3110
Tmax XT3 CB + diff. mod.	4	300	LX3004		LX3004	LX3104
Tmax XT4	3 ⁽²⁾ /4	200	LX4003		LX4003	
Tmax XT4 CB + diff. mod.	4	200	LX4004		LX4004	

⁽¹⁾ Version for Tmax with differential module underplaced RC 221/222.

⁽²⁾ For 3 poles breakers please order accessory flange codes: **AD3305** XT1 3P Flange for plate-mounting - **AD3306** XT2 3P Flange for plate-mounting - **AD3307** XT3 3P Flange for plate-mounting - **AD3308** XT4 3P Flange for plate-mounting

Vertical installation

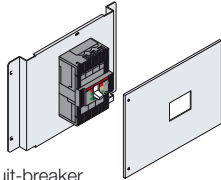

Circuit-breaker front terminals	No. poles	Dimensions H (mm)	Fixed				
			Wall-mounted structures		Floor-mounted structures		
			Structure 24 DIN mod. W=600mm	Cable container side by side W=300mm	Structure 24 DIN mod. W=600mm	Structure 36 DIN mod. W=800mm	Cable container side by side W=300mm
Tmax T1-T2-T3 on DIN 35 rail		200	(see page 3/6)		(see page 3/6)	(see page 3/6)	(see page 3/6)
Tmax T1	3-4	200	LK1001		LK1001	LK1101	LK1002
Tmax T1 CB + diff. mod.	4	300					LK1008 ⁽¹⁾
Tmax T1 No. 4 CBs side by side	3-4	200			LK4100	LK4108*	
Tmax T2	3-4	200	LK2001		LK2001	LK2101	LK2002
Tmax T2 CB + diff. mod.	4	300					LK2008
Tmax T2 No. 3 CBs side by side	3-4	200			LK3200	LK3111**	
Tmax T3	3-4	300	LK3001	LK3003	LK3001	LK3101	LK3002
Tmax T3 CB + diff. mod.	4	300	LK3005		LK3005	LK3105	LK3008
Tmax T3 No. 3 CBs side by side	3-4	300			LK3300	LK3102**	
Tmax T4	3-4	400			LK4005	LK4105	LK4007
Tmax T4 CB + diff. mod.	4	500			LK4006	LK4106	
Tmax T5	3-4	400			LK5005	LK5105	LK5007
Tmax T5 CB + diff. mod.	4	500			LK5006	LK5106	LK5008
Tmax T6	3-4	500			LK6011	LK6012	
Tmax XT1	3 ⁽²⁾ /4	200	LX1001		LX1001	LX1101	LX1002
Tmax XT1 CB + diff. mod.	4	300	LX1006		LX1006	LX1108	LX1008
Tmax XT1 N 3 CBs side by side	3 ⁽²⁾ /4	200	LX4100		LX4100		
Tmax XT3	3 ⁽²⁾ /4	300	LX3001	LX3003	LX3001	LX3101	LX3002
Tmax XT3 CB + diff. mod.	4	300	LX3005		LX3005	LX3105	LX3008
Tmax XT3 N 2 CBs side by side	3 ⁽²⁾ /4	300	LX3300		LX3300		
Tmax XT4	3 ⁽²⁾ /4	300	LX4005		LX4005		LX4007
Tmax XT4 CB + diff. mod.	4	400	LX4006		LX4006		

* No. 5 circuit-breakers only for structures W=800mm.

** No. 4 circuit-breakers only for structures W=800mm.

⁽¹⁾ Version for Tmax with differential module underplaced RC 221/222.

⁽²⁾ For 3 poles breakers please order accessory flange codes: **AD3305** XT1 3P Flange for plate-mounting - **AD3306** XT2 3P Flange for plate-mounting - **AD3307** XT3 3P Flange for plate-mounting - **AD3308** XT4 3P Flange for plate-mounting **For Isomax kits, please see page 9/83.**

For Isomax kits, please see page 9/83.

Selection by componentspage 9/12

In-depth technical informationpage 6/10

Overall dimensionspage 8/6

ArTu L modular structures

Kit for installing apparatus

Plain back plates, plain and ventilated panels

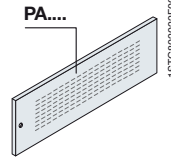
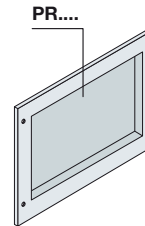
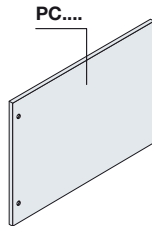
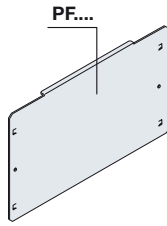

1STCRA0202F0001

H (mm)	Back plates			Panels						
	Structure 24 DIN mod. W=600mm	Plain flat Structure 36 DIN mod. W=800mm	Cable container W=300mm	Structure 24 DIN mod. W=600mm	Plain flat Structure 36 DIN mod. W=800mm	Cable container W=300mm	Structure 24 DIN mod. W=600mm	Structure 36 DIN mod. W=800mm	Int.cable container W=300mm	Ventilated Structure 24 DIN mod. W=600mm
50				PC1050	PC0580					
100				PC1600	PC1800	PC1403				PA1600
150				PC1150	PC1580					
200	PF1002	PF1102		PC2600	PC2800	PC2401	PR2600	PR2800		PA2600
300	PF1003	PF1103	PC0300	PC3600	PC3800	PC3401				
400	PF1004	PF1104		PC4600	PC4800	PC4401	PR4600	PR4800	PR4401	
600	PF1006	PF1106	PC0600	PC6600	PC6800	PC6401	PR6600	PR6800		
800	PF1008	PF1108		PC8600	PC8800	PC8401				
1600				PC1660	PC1680					
1800				PC1860	PC1880					
2000				PC2060	PC2080					

Can be used to mount all the non-modular apparatus. For useful dimensions, please see page 8/20.

Kit for OT200/250/315/400

vertical installation

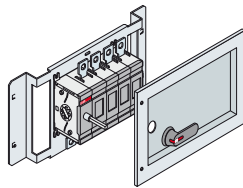

horizontal installation

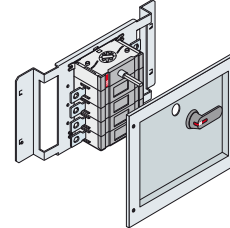

H (mm)	Width structure (mm)		
300	600	KO1260	KO1261
300	800	KO1280	KO1281
300	300	KO1262	

Useful internal space

Wall-mounted structure

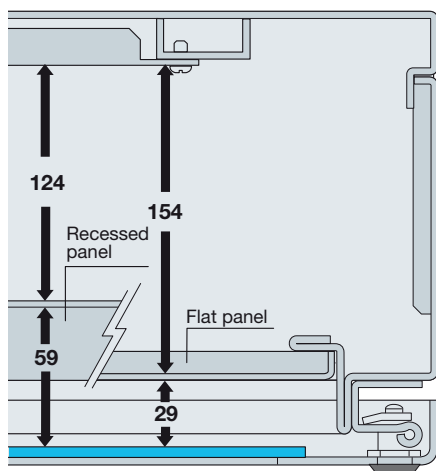

Floor-mounted structure

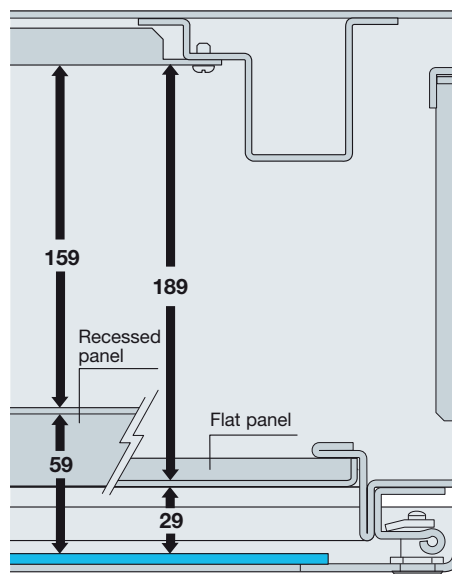

Cable connection box

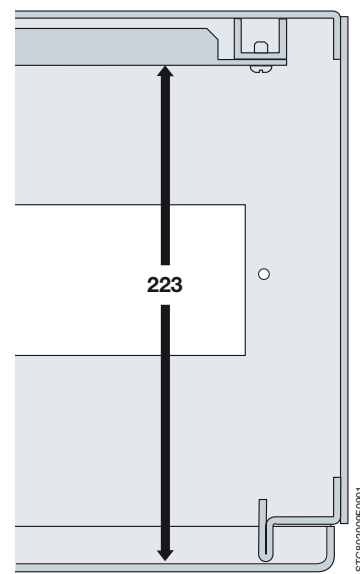

1STCRA0202F0001

ArTu L modular structures

Kit for installing apparatus

Panels for square measuring instruments

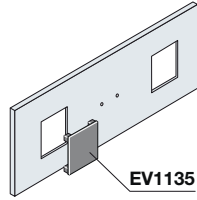

2-instrument panel

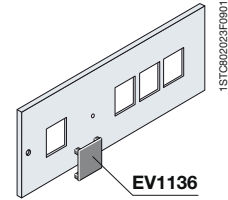

4-instrument panel

H (mm)	72x72mm		96x96mm		72x72mm		96x96mm	
	24 mod.DIN W=600mm	36 mod.DIN W=800mm	24 mod.DIN W=600mm	36 mod.DIN W=800mm	24 mod.DIN W=600mm	36 mod.DIN W=800mm	24 mod.DIN W=600mm	36 mod.DIN W=800mm
200	PS2720	PS2728	PS2960	PS2968	PS4720	PS4728	PS4960	PS4968

These allow installation of measuring instruments and relative changeover switches.

Square instrument hole covers

Code	Description
EV1135	Hole cover of 72x72mm instrument black RAL 9005
EV1136	Hole cover of 96x96mm instrument black RAL 9005

Installation of terminal boxes on DIN rail

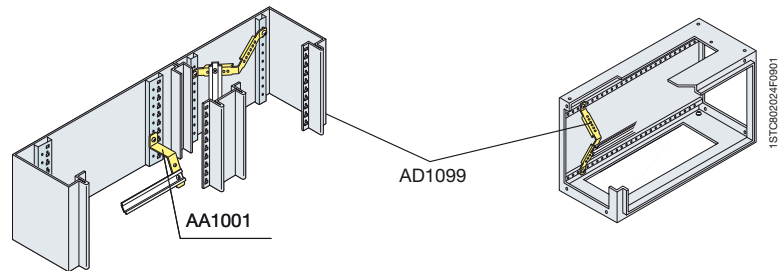

Terminal box mounting position

Installation on DIN rail
Horizontal
Horizontal angled 45°
Vertical

Structure	Internal cable container	Cable container side-by-side	Box
AA1001			AD1099
	AD1005	AD1099	

Installation of terminal boxes on DIN rail and earthing busbar

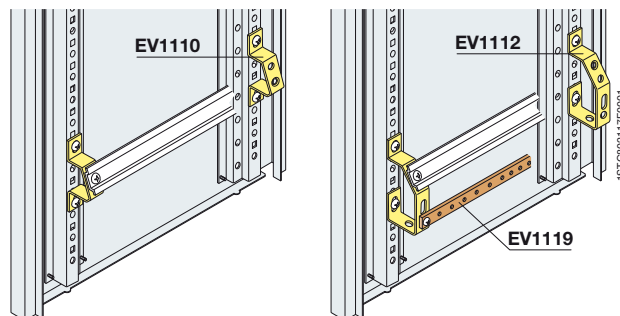

Angled supports for terminal boxes and earthing busbar

Code	Description
EV1110	Angled supports 1 row of terminals
EV1112	Angled supports 1 row of terminals + earth

ArTu L modular structures

Distribution systems

Modular dividers

Single-pole

Three-poles

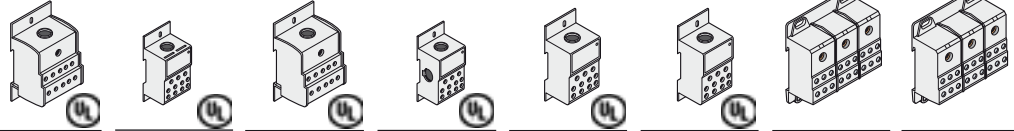

Code		AD1076	AD1080 ⁽¹⁾	AD1007	AD1081 ⁽²⁾	AD1030	AD1031	AD1075	AD1006
In (A)		125	125	160	160	250	400	125	160
Icw (kA)		4.2	4.2	11	11	21	21	11	4.2
Version	poli	1	1	1	1	1	1	3	3
Installation		DIN35/plate	DIN35/plate	DIN35/plate	DIN35/plate	DIN35/plate	DIN35/plate	DIN35/plate	DIN35/plate
Power supply Ø cable (mm ²)	min.	10	6	16	10	35	95	10	16
	max	35	35	70	70	120	185	35	70
No. outgoing feeder Ø cable (mm ²)	2,5÷10					4	4		
	2,5÷16	10	6	10	6	5	5	6	6
	2,5÷25					2	2		
	2,5÷35								
Dimensions HxWxD (mm)		71x45x42,5	75x25x47	71x45x42,5	92x35x49	96x45x49	96x45x49	80x71,5x42,5	80x71,5x42,5
No. DIN modules		2,5	1,5	2,5	2	3	3	4,5	4,5
Rated service voltage Ue (V)		690	500	690	500	500	500	690	690
Degree of protection	IP	20	20	20	20	20	20	20	20

Four-poles

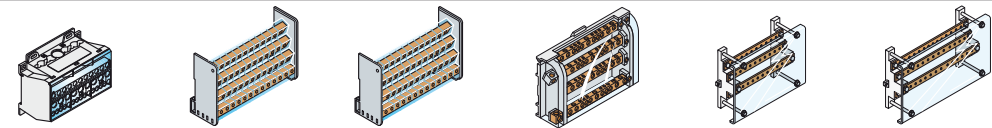

Code		AD1004	AD1028	AD1029	AD1027	AD1034	AD1053
In (A)		125	125	125	160	250	250
Icw (kA)		4.2	4.2	4.2	6.2	15	15
Version	poles	4	4	4	4	4	4
Installation		DIN35/plate	DIN35/plate	DIN35/plate	DIN35	with AD1038 brackets	with AD1038 brackets
Power supply Ø cable (mm ²)	min.	6	6	6	10		
	max	35	25 with cable terminal 35 without cable terminal	25 with cable terminal 35 without cable terminal	50		
No. outgoing feeder Ø cable (mm ²)	5 holes/phase Ø1÷6		2xØ6÷25 + cable terminal	2xØ6÷25 + cable terminal	8xØ2,5÷16	No. 22 holes M5 with 17,5mm pitch per phase (threaded busb. 20x5mm)	No. 32 holes M5 with 17,5mm pitch per phase (threaded busb. 20x5mm)
	2 holes/phase Ø1,5÷16		2xØ6÷35 no cable terminal	2xØ6÷35 no cable terminal	3xØ6÷35		
	6 holes/neutral Ø1,5÷16		9xØ6÷10	2xØ6÷16			
	4 holes/neutral Ø1,5÷6 ²			9xØ6÷10			
Dimensions HxWxD (mm)		45x75x98	89x93x48	126x93x48	90x160x50	150x600x70	150x800x70
No. DIN modules		5,5	5	7	9	24	36
Rated service voltage Ue (V)		500	690	690	500	500	500
Degree of protection	IP	20	20	20	20		

⁽¹⁾ possibility of putting in parallel with AD1083 connections.

⁽²⁾ possibility of putting in parallel with comb type connection (not supplied).

Flexible busbars up to 1000A

Cross-section	In (A)	Code	No. busbar/phase	capacity (A)			WxW (mm)	Section dimensions (mm ²)	Lenght (mm)	Weight (kg)
				IP31	IP41	IP65				
	250	BF1602	1	395	323	250	20x3	60	2000	1,42
	400	BF2502	1	498	460	400	20x5	100	2000	2,15
	500	BF4002	1	660	620	500	24x6	144	2000	3
	630	BF4012 ⁽¹⁾	1	758	702	630	32x5	160	2000	3,36
	1000	BF6302	1	1203	1140	1000	40x8	320	2000	6,33

⁽¹⁾ Only for front extended terminals and rear terminals.

ArTu L modular structures

Distribution systems

Selection of busbar holders and crosspieces

Vertical installation

Horizontal installation

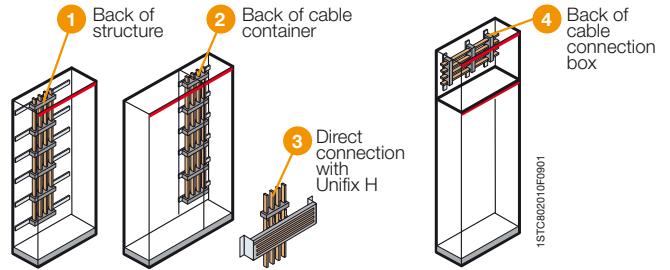
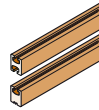

Busbar holder

Busbars with shaped section

Crosspieces for fixing to structure

Type	In ≤ 400÷800A	Installation	Structure	Cable container	Internal cable container	Cable connection box
Scaled up to 800A PB0802 	BA0400 BA0800	2		TL2000 (W=300mm)	TL2100 (W=200mm)	
		4				TL2000 (H=300mm)
Linear up to 800A PB0803 	BA0400 BA0800	1	TL1000 (W=600mm) TL1100 (W=800mm)			
		2		TL3000 (W=300mm)		
		3	TL1000 (W=600mm) TL1100 (W=800mm)			
		4				TL3000 (H=300mm)

3

Busbars with shaped section for applications up to 800 A

Section	In (A)	Code	No. busbar/phase	capacity (A)		Icw max (kA)	WxW (mm)	Section dimensions (mm ²)	Length (mm)	Weight (kg)
				IP31	IP43					
	520	BA0400	1	630	520	35	20x20	200	1730	4
	830	BA0800	1	970	830	35	20x20	283	1730	4,4

Table for selection and assembly of busbars with shaped section and busbar holders

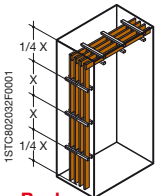

The distance between the first busbar holder and the end of the busbar must not exceed $\frac{1}{4}$ of "X".

max X = maximum distance not to be exceeded between two consecutive busbar holders

No. of busbar holders according to the max. I_{cc}

Busbar code	capacity	Busbar holder code	No. busbars per phase	25 kA		35 kA		50 kA		65 kA		75 kA		85 kA		100 kA	
				X max (mm)	X max (mm)	X max (mm)	X max (mm)	X max (mm)	X max (mm)	X max (mm)	X max (mm)						
Linear																	
BA0400	400A	PB0803	1	4	550	5	425	-	-	-	-	-	-	-	-	-	-
BA0800	800A	PB0803	1	4	550	4	550	-	-	-	-	-	-	-	-	-	-
Scaled																	
BA0400	400A	PB0802	1	4	550	4	550	-	-	-	-	-	-	-	-	-	-
BA0800	800A	PB0802	1	4	550	4	550	-	-	-	-	-	-	-	-	-	-

The use of the correct number of busbar holders ensures resistance to electrodynamic forces in the case of a short-circuit. Assess the maximum distance (max X) which must not be exceeded between two consecutive busbar holders according to the max. I_{cc}.

ArTu L modular structures

Distribution systems

Prefabricated kits for connections between apparatus and busbars with shaped section 400/800A

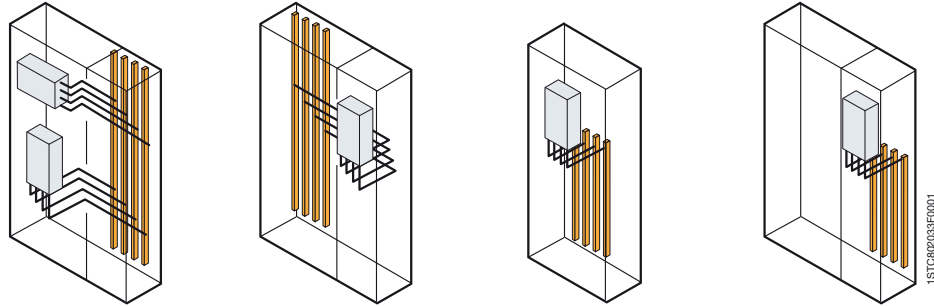

Apparatus

Connection kit

Type of installation	From circuit-breaker in structure towards busbars in cable container	From circuit-breaker in cable container towards busbars in structure	From circuit-breaker in structure towards busbars on back of structure	From circuit-breaker in cable container towards busbars on back of structure
Type of busbar holder	Scaled PB0802	Linear PB0803	Linear PB0803	Linear PB0803
Apparatus with front terminals				
fixed horizontal installation				
Tmax T1 4 poles	KB1001 ⁽¹⁾			
Tmax T2 4 poles	KB1001			
Tmax T3 4 poles	KB1002			
Tmax T5 4 poles	KB1020			
Tmax T5 4 poles CB + diff. mod.	KB1021			
Apparatus with front terminals				
fixed vertical installation				
Tmax T3 4 poles	KB1006	KB1010	KB1014 / KB1018 ⁽²⁾	KB1014 / KB1018 ⁽²⁾
Tmax T3 4 poles (w/mount. struct)	KB1006	KB1010	KB1014	KB1014
Tmax T3 4 poles CB + diff.mod.		KB1019		
Tmax T5 4 poles	KB1022	KB1024		
Tmax T5 4 poles CB + diff.mod.	KB1022	KB1024		

⁽¹⁾ For Tmax T1 fit the circuit-breaker with extended terminals.

⁽²⁾ KB1018: only with flat busbars and scaled busbar holder.

Apparatus

Dimensions of the conductors

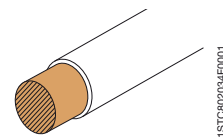
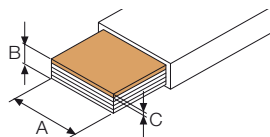

Apparatus

Apparatus	AxBxC (mm)	cross-section (mm ²)
Tmax T1-T2		50
Tmax T3	20x5x1	150
Tmax T5 630A	32x6x1	

The use of the prefabricated connection kits is only possible with the cable container mounted on the right of the structure.

ArTu L modular structures

Distribution systems

Selection of busbar holders and crosspieces

Vertical installation

Horizontal installation

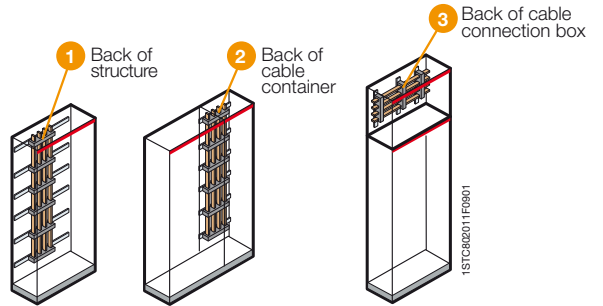
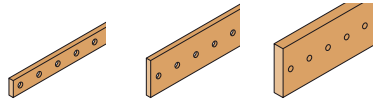

Busbar holder

Busbars with flat section

Crosspieces for fixing to structure

Type

Scaled up to 630A
BP0634

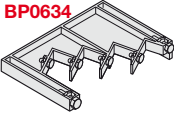

Scaled up to 630A
BP0630

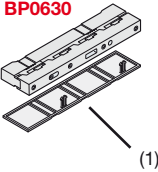

In=250A	In=400A	In=630A
BR0250	BR0400	BR0630
BR0250	BR0400	BR0630

Installation	Structure	Cable container	Cable connection box
2		TL3000 (W=300mm)	
3			TL3000 (H=300mm)
1	TL1000 (W=600mm) TL1100 (W=800mm)		
2		TL3000 (W=300mm)	
3			TL3000 (H=300mm)

(1) The busbar terminal protection covers must be ordered separately BP0632.

Flat busbars for distribution up to 630A

Cross-section	In (A)	Code	No. busbar/phase	capacity (A)		max Icw (kA)	WxW (mm)	Length (mm)	Weight (kg)
				IP31	IP43				
	275	BR0250	1	290	275	23	15x5	1750	1,35
	440	BR0400	1	475	440	23	25x5	1750	1,8
	695	BR0630	1	750	695	32	30x10	1750	4,4

ArTu L modular structures

Distribution systems

Table for selection and assembly of busbars with flat section and busbar holders

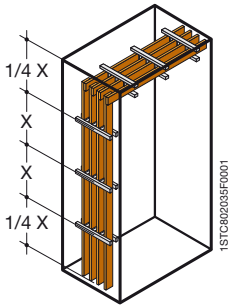

The distance between the first busbar holder and the end of the busbar must not exceed $\frac{1}{4}$ of "X".

No. of busbar holders according to the max. I_{cc}

Busbar code	capacity	Busbar holder code	No. busbars per phase	16 kA		20 kA		23 kA		32 kA	
				max X (mm)	max X (mm)	max X (mm)	max X (mm)	max X (mm)	max X (mm)		
BR0250	250A	BP0634	1	11	175	15	125	18	100	-	-
BR0400	400A		1	9	225	15	125	18	100	-	-
BR0630	630A		1	9	225	15	125	18	100	-	-
BR0250	250A	BP0630	1	4	500	6	350	10	200	-	-
BR0400	400A		1	4	500	6	350	10	200	-	-
BR0630	630A		1	-	-	4	600	4	600	9	210

max X = maximum distance not to be exceeded between two consecutive busbar holders

The use of the correct number of busbar holders ensures resistance to electrodynamic forces in the case of a short-circuit. Assess the maximum distance (max X) which must not be exceeded between two consecutive busbar holders according to the max. I_{cc} .

Flat drilled and threaded busbars for earthing connections

Cross-section	Code	Threading	Pitch	WxW (mm)	Length (mm)	AxB (mm)
	EV1119	6 MA	20	20x5	2000	
	EV1120	6 MA	20	25x5	2000	
	EV1121	6MA	25	50x5	2000	
	EV1122	6MA				34x30
	EV1123	8MA				34x30
	EV1124	6MA				40x50
	EV1125	8MA				40x50

ArTu L modular structures

Distribution systems

Technical characteristics	Unifix H	Unifix L
Rated service voltage (U_n)	690V AC	400V AC
Rated insulation voltage (U)	1000V AC	500V AC
Rated impulse withstand voltage (U_{imp})	8kV	6kV
Rated frequency	50/60Hz	50/60Hz
Rated current (I_n)	central power supply 400A lateral power supply 320A	100A 80A
Rated short-time withstand current (I_{cw})	25kA	
Maximum peak current (I_{pk})	52,5kA-400V	
Maximum installable circuit-breaker size	250A	100A
Conditioned short-circuit current (I_{cc})	Tmax T1	36kA-400V
	Tmax T2 N, S ⁽¹⁾	50kA-400V
	Tmax T3	50kA-400V
	Tmax XT1	50kA-400V
	Tmax XT3	50kA-400V
With circuit-breaker	S200	6kA-400V
	S200 M	10kA-400V
	S200 P	25kA-400V
Degree of protection	IP20 with accessory	IP20
Characteristics of the insulating material	Self-extinguishing thermoplastic V1 (UL94)	Self-extinguishing thermoplastic V1 (UL94)
Characteristics of the conductor material	Electrolytic copper	Electrolytic copper
Width (No. modules/mm)	24/600	12/400
	36/800	24/600 36/800

Installation of Unifix system

Frame for Tmax T and Tmax XT series	300x600mm (hxl) 300x800mm (hxl)	ED2183 ED2191	
Fixing brackets H=300mm		AD1097	
Crosspiece for direct connection to the rear busbars with shaped section with PB0803	W=600mm W=800mm	TL1000 TL1100	
Busbar 2P	12 mod.		ED2993
	18 mod.		ED3009
	24 mod.		ED3017
	36 mod.		ED3025
Busbar 4P	12 mod.		ED2944
	18 mod.		ED2951
	24 mod.		ED2969
	36 mod.		ED2977
Fixing support	24 mod.		GD1520
	36 mod.		GD1530

⁽¹⁾ Select circuit-breakers in version with front terminals for copper cables.

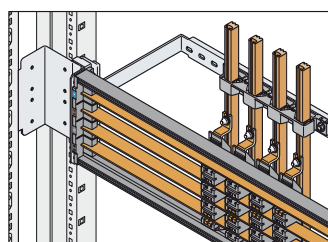

Direct connection with the 400/800A system of busbars with shaped section.

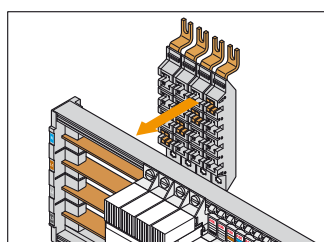

Feeder module for 400A frame (L1-L2-L3-N).

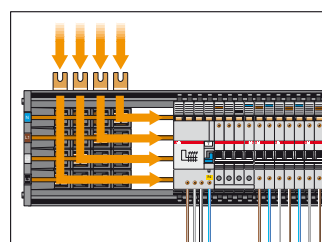

Direct power supply of the bases by means of feeder module ED2209.

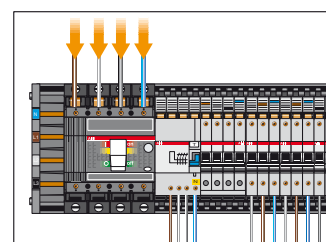

Power supply by means of general row circuit-breaker.

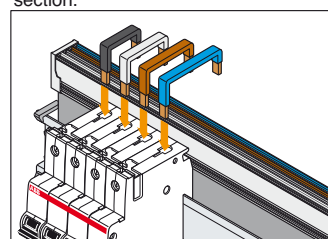

Connections (L1-L2-L3-N) for System Pro M modular apparatus.

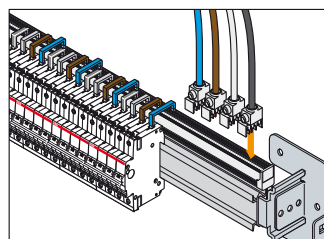

Power supply of the busbar with 100A feeder module without cable. Terminal capacity 35mm².

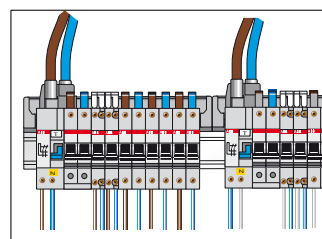

Direct power supply of the busbars by means of feeder module.

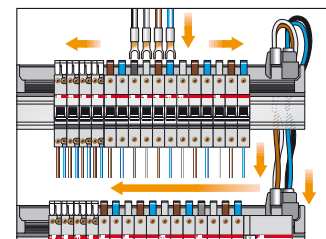

Power supply by means of modules and cables in parallel.

ArTu L modular structures

Distribution systems

Table for selecting connections according to the circuit-breaker

Circuit-breaker series	Unifix H	Unifix L
S941 - S951 - S971 DS941 - DS951 - DS971	(top power supply) ED2654 L1/N 40A ED2662 L2/N 40A ED2670 L3/N 40A	ED3272 L1/N 40A ED3280 L2/N 40A ED3298 L3/N 40A
S200 - DS 200 F200 up to 63A (Unifix L)	(top power supply) (bottom power supply) ED2531 L1 63A ED2572 L1 63A ED2549 L2 63A ED2590 L2 63A ED2556 L3 63A ED2598 L3 63A ED2564 N 63A ED2606 N 63A ED2845 False pole module	ED3033 L1 100A ED3041 L2 100A ED3058 L3 100A ED3066 N 100A
S800	(top power supply) ED2557 L1 ≤32A ED2558 L2 ≤32A ED2559 L3 ≤32A ED2560 N ≤32A ED2551 L1 125A ED2552 L2 125A ED2553 L3 125A ED2554 N 125A ED2550 False pole module	
F660 - F670 - S280 (80-100A) E200 up to 100A - RS370 - F200 80/100A (Unifix H)	(bottom power supply) ED2720 L1 100A ED2738 L2 100A ED2746 L3 100A ED2753 N 100A	ED3132 L1/L2/L3/N pow. supply - 350mm ED0026 L1/L2/L3/N pow. supp.- 1500mm ED0025 L1/L2/L3/N pow. supp. - 2500mm
MDRC - Various apparatus	(bottom power supply) (bottom power supply) ED2894 L1/N 16A ED2910 L1/N 16A ED2902 L1/L2 16A ED2928 L1/L2 16A	ED3108 Power supply 2 cab. L1/N 16A ED3116 Pow. supply 3 cab. L1/L2/L3 16A ED3124 Pow. supp. 4 cab. L1/L2/L3/N 16A ED3355 Power supply 2 cab. L1/N 40A ED3363 Pow. supply 3 cab. L1/L2/L3 40A ED3371 Pow. supp. 4 cab. L1/L2/L3/N 71A
Tmax T1 Tmax XT1	(top/bottom power supply) ED2217 L1 Top/L2 Bottom ED2225 L2 Top/L1 Bottom ED2233 L3 Top/N Bottom ED2241 N Top/L3 Bottom ED2373 False pole module ED2381 False pole module	
Residual current Solenoid operator		
Tmax T2	(top/bottom power supply) ED2258 L1 Top/L2 Bottom ED2266 L2 Top/L1 Bottom ED2274 L3 Top/N Bottom ED2282 N Top/L3 Bottom ED2373 False pole module ED2399 False pole module	
Residual current Solenoid operator		
Tmax T3 Tmax XT3	(top power supply) (bottom power supply) ED2290 L1 ED2332 L1 ED2308 L2 ED2340 L2 ED2316 L3 ED2357 L3 ED2324 N ED2365 N ED2373 False pole module	
Residual current		

For the DDA locks, order the false module **ED2845** codes separately according to the size of the residual current lock.

ArTu L modular structures

Examples of configuration

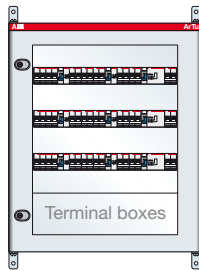

ArTu L dim.800x600x165 (850x690x204) mm (external hxwxd) IP43 with modular panels

Code	Description	Q.ty
SL0800	Back structure 800x700x200mm (hxwxd)	1
MC0800	Blind riser h=800mm	1
PV0800	Glass door x structure h=800mm	1
AL2000	No.2 wall fixing brackets L	2
PM6672	Panel 72 mod.600x600mm (hxw) M, K	1
PC2600	Plain panel 200x600mm (hxw) M, K	1
GD1520	DIN rail, pitch 150/200mm	3

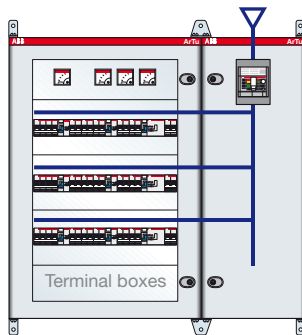

ArTu L dim.1000x900x165 (1050x1080x204) mm (external hxwxd) IP43 with cable container, plate for Tmax T3, modular panels lcw 16kA complete with busbar holder, 250A busbars and Unifix L

Code	Description	Q.ty
SL1000	Back structure 1000x700x200mm (hxwxd)	1
MC1000	Blind riser h=1000mm	1
PV1000	Glass door x structure h=1000mm	1
PC2600	Plain panel 200x600mm (hxw) M, K	1
PM2624	Panel 24 mod.200x600mm (hxw) M, K	3
PS4720	Panel 4 strum.72x72 200x600mm (hxw) M, K	1
MI1000	Riser CB side-by-side structures h=1000mm	1
VC1000	Cable container h=1000mm	1
PC1002	Blind door x cable container h=1000mm	1
LK3003	Kit wallT3 vert. in cable cont.	1
PC6401	Plain panel h=600mm	1
PC1403	Plain panel h=100mm	1
TL3000	Linear crosspiece x cable container	3
BP0630	N °2 flat busbar holders 250-630A	2
BR0250	N °2 flat busbars 250A	1
AL2000	N °2 wall fixing brackets L	2
AA1000	N °2 fixing brackets wall side-by-side structures	1
ED2969	4P busbar 24 modules	3
ED3132	Feeder+cable l=350mm 4P 100A	3
ED... ^(*)	Connection L 1-L2-L3-N	
GD1520	DIN rail, pitch 150/200mm	3
AD1096	N °4 horz./vert. wall wiring duct metal support	1

(*) For selection of the connection according to the circuit-breaker, see page 3/15.

ArTu L dim.1000x900x165 (1050x1080x204) mm (external hxwxd) IP43 with cable container, plate for Tmax XT3, modular panels lcw 16kA complete with busbar holder, 250A busbars and Unifix L

Code	Description	Q.ty
SL1000	Back structure 1000x700x200mm (hxwxd)	1
MC1000	Blind riser h=1000mm	1
PV1000	Glass door x structure h=1000mm	1
PC2600	Plain panel 200x600mm (hxw) M, K	1
PM2624	Panel 24 mod.200x600mm (hxw) M, K	3
PS4720	Panel 4 strum.72x72 200x600mm (hxw) M, K	1
MI1000	Riser CB side-by-side structures h=1000mm	1
VC1000	Cable container h=1000mm	1
PC1002	Blind door x cable container h=1000mm	1
LX3003	Kit XT3 3/4 P vert. in cable cont. L wall	1
PC6401	Plain panel h=600mm	1
PC1403	Plain panel h=100mm	1
TL3000	Linear crosspiece x cable container	3
BP0630	No.2 flat busbar holders 250-630A	2
BR0250	No.2 flat busbars 250A	1
AL2000	No.2 wall fixing brackets L	2
AA1000	No.2 fixing brackets wall side-by-side structures	1
ED2969	4P busbar 24 modules	3
ED3132	Feeder+cable l=350mm 4P 100A	3
ED... ^(*)	Connection L 1-L2-L3-N	
GD1520	DIN rail, pitch 150/200mm	3
AD1096	No. 4 horz./vert. wall wiring duct metal support	1

(*) For selection of the connection according to the circuit-breaker, see page 3/15.

ArTu L modular structures

Distribution systems

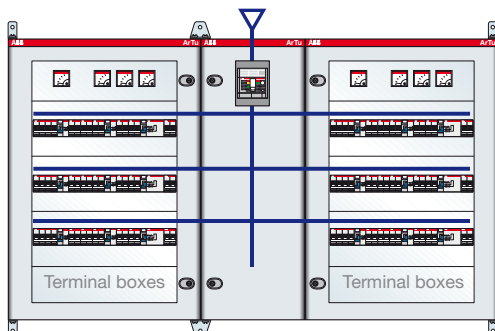

ArTu L Series dim.1000x1500x165 (1050x1770x204) mm (external hxxxd) IP43 with cable container, plate for Tmax T3, modular panels lcw 16kA complete with busbar holder, 250A busbars and Unifix L

Code	Description	Q.ty
SL1000	Back structure 1000x700x200mm (hxxxd)	2
MC1000	Blind riser h=1000mm	1
PV1000	Glass door x structure h=1000mm	2
PC2600	Plain panel 200x600mm (hxx) M, K	3
PM2624	Panel 24 mod.200x600mm (hxx) M, K	6
PS4720	Panel 4 strum.72x72 200x600mm (hxx) M, K	1
MI1000	Riser CB side-by-side structures h=1000mm	2
VC1000	Cable container h=1000mm	1
PC1002	Blind door x cable container h=1000mm	1
LK3003	Kit wall T3 vert. in cable cont.	1
PC6401	Plain panel h=600mm	1
PC1403	Plain panel h=100mm	1
AL2000	N °2 wall fixing brackets L	2
AA1000	N °2 fixing brackets wall side-by-side structures	2
GD1520	DIN rail, pitch 150/200mm	6
ED2969	4P busbar 24 modules	6
ED3132	Feeder+cable l=350mm 4P 100A	6
ED... ^(*)	Connection L 1-L2-L3-N	
TL3000	Linear crosspiece x cable container	3
BP0630	N °2 flat busbar holders 250-630A	2
BR0250	N °2 flat busbars 250A	1
AD1096	N °4 horz./vert. wall wiring duct metal support	2

(*) For selection of the connection according to the circuit-breaker, see page 3/15.

ArTu L Series dim.1000x1500x165 (1050x1770x204) mm (external hxxxd) IP43 with cable container, plate for Tmax XT3, modular panels lcw 16kA complete with busbar holder, 250A busbars and Unifix L

Code	Description	Q.ty
SL1000	Back structure 1000x700x200mm (hxxxd)	2
MC1000	Blind riser h=1000mm	1
PV1000	Glass door x structure h=1000mm	2
PC2600	Plain panel 200x600mm (hxx) M, K	3
PM2624	Panel 24 mod.200x600mm (hxx) M, K	6
PS4720	Panel 4 strum.72x72 200x600mm (hxx) M, K	1
MI1000	Riser CB side-by-side structures h=1000mm	2
VC1000	Cable container h=1000mm	1
PC1002	Blind door x cable container h=1000mm	1
LX3003	Kit XT3 3/4 P vert. in cable cont. L wall	1
PC6401	Plain panel h=600mm	1
PC1403	Plain panel h=100mm	1
AL2000	No.2 wall fixing brackets L	2
AA1000	No.2 fixing brackets wall side-by-side structures	2
GD1520	DIN rail, pitch 150/200mm	6
ED2969	4P busbar 24 modules	6
ED3132	Feeder+cable l=350mm 4P 100A	6
ED... ^(*)	Connection L 1-L2-L3-N	
TL3000	Linear crosspiece x cable container	3
BP0630	No.2 flat busbar holders 250-630A	2
BR0250	No.2 flat busbars 250A	1
AD1096	No.4 horz./vert. wall wiring duct metal support	2

(*) For selection of the connection according to the circuit-breaker, see page 3/15.

ArTu L modular structures

Examples of configuration

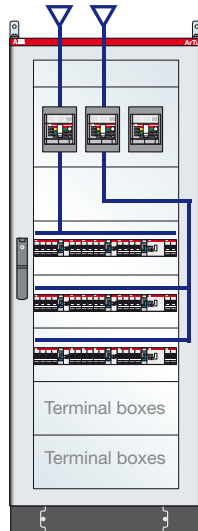

ArTu L Series dim.1600x600x195 (1750x690x240) mm (external hxwxd) IP43 with plate for n° 3 Tmax T3, modular panels, 250A divider and Unifix L

Code	Description	Q.ty
SL1600	Back structure 1600x700x240mm (hxwxd)	1
ZL1000	Base strips x structure	1
ZL1001	Structure flanges	1
MC1600	Blind riser h=1600mm	1
PV1600	Glass door x structure h=1600mm	1
LK3300	Kit floor x n °3 T3 side-by-side	1
PM2624	Panel 24 mod.200x600mm (hxw) M, K	3
PC2600	Plain panel 200x600mm (hxw) M, K	3
PC1600	Plain panel 100x600mm (hxw) M, K	1
AL2000	N °2 wall fixing brackets L	1
AD1034	Horiz. busbar Kit 250A l=600mm	1
AD1038	N °2 divider fixing brackets AD1034	1
ED2969	4P busbar 24 modules	3
ED3132	Feeder+cable l=350mm 4P 100A	1
GD1520	DIN rail, pitch 150/200mm	3
ED3090	Feeder+cable l=600mm parallel 4P 100A	2
AD1098	N °4 floor wiring duct supports	2

(*) For selection of the connection according to the circuit-breaker, see page 3/15.

ArTu L Series dim.1600x600x195 (1750x690x240) mm (external hxwxd) IP43 with plate for No. 3 Tmax XT3, modular panels, 250A divider and Unifix L

Code	Description	Q.ty
SL1600	Back structure 1600x700x240mm (hxwxd)	1
ZL1000	Base strips x structure	1
ZL1001	Structure flanges	1
MC1600	Blind riser h=1600mm	1
PV1600	Glass door x structure h=1600mm	1
LX3300	Kit No.3 XT3 side-by-side L floor	1
PM2624	Panel 24 mod.200x600mm (hxw) M, K	3
PC2600	Plain panel 200x600mm (hxw) M, K	3
PC1600	Plain panel 100x600mm (hxw) M, K	1
AL2000	No.2 wall fixing brackets L	1
AD1034	Horiz. busbar Kit 250A l=600mm	1
AD1038	No.2 divider fixing brackets AD1034	1
ED2969	4P busbar 24 modules	3
ED3132	Feeder+cable l=350mm 4P 100A	1
GD1520	DIN rail, pitch 150/200mm	3
ED3090	Feeder+cable l=600mm parallel 4P 100A	2
AD1098	No.4 floor wiring duct supports	2

(*) For selection of the connection according to the circuit-breaker, see page 3/15.

ArTu L modular structures

Examples of configuration

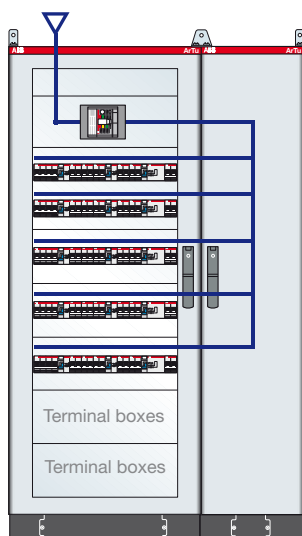

ArTu L Series dim.1600x900x195 (1750x1080x240) mm (external hxwxd) IP43 with cable container, plate for Tmax T3, modular panels lcw 25kA complete with busbar holder, 400A busbars, connections to the circuit-breaker, Unifix H and L

Code	Description	Q.ty
SL1600	Back structure 1600x700x240mm (hxwxd)	1
ZL1000	Base strips x structure	1
ZL1001	Structure flanges	1
MC1600	Blind riser h=1600mm	1
PV1600	Glass door x structure h=1600mm	1
PC1600	Plain panel 100x600mm (hxw) M, K	1
LK3000	T3 floor/wall Kit horiz.3/4P	1
PM3648	Panel 48 mod.300x600mm (hxw) M, K	1
PM2624	Panel 24 mod.200x600mm (hxw) M, K	3
PC2600	Plain panel 200x600mm (hxw) M, K	2
MI1600	Riser CB side-by-side structures h=1600mm	1
ZL3000	Base strips x side-by-side ass.	1
VC1600	Cable container h=1600mm	1
ZL2001	Cable container flanges	1
PC1602	Blind door x cable container h=1600mm	1
AL2000	N °2 wall fixing brackets L	1
AA1000	N °2 fixing brackets wall side-by-side structures	1
ED2969	4P busbar 24 modules	3
ED3132	Feeder+cable l=350mm 4P 100A	1
GD1520	DIN rail, pitch 150/200mm	3
ED3090	Feeder+cable l=600mm parallel 4P 100A	2
TL2000	Scaled crosspiece x cable container	4
PB0802	Scaled busbar holder In=800A (35 kA)	2
BA0400	Busbar In=400A	2
KB1002	Connections T3 floor/wall	1
ED2183	Frame with busbars 24 modules	1
AD1097	Unifix H fixing brackets	1
AD1064	N °12 joining screws l=27 x flat busbars up to 10mm	1
AD1098	N °4 floor wiring duct supports	2

(*) For selection of the connection according to the circuit-breaker, see page 3/15.

ArTu L Series dim.1600x900x195 (1750x1080x240) mm (external hxwxd) IP43 with cable container, plate for Tmax XT3, modular panels lcw 25kA complete with busbar holder, 400A busbars, connections to the circuit-breaker, Unifix H and L

Code	Description	Q.ty
SL1600	Back structure 1600x700x240mm (hxwxd)	1
ZL1000	Base strips x structure	1
ZL1001	Structure flanges	1
MC1600	Blind riser h=1600mm	1
PV1600	Glass door x structure h=1600mm	1
PC1600	Plain panel 100x600mm (hxw) M, K	1
LX3300	Kit No.3 XT3 side-by-side L floor	1
PM3648	Panel 48 mod.300x600mm (hxw) M, K	1
PM2624	Panel 24 mod.200x600mm (hxw) M, K	3
PC2600	Plain panel 200x600mm (hxw) M, K	2
MI1600	Riser CB side-by-side structures h=1600mm	1
ZL3000	Base strips x side-by-side ass.	1
VC1600	Cable container h=1600mm	1
ZL2001	Cable container flanges	1
PC1602	Blind door x cable container h=1600mm	1
AL2000	No.2 wall fixing brackets L	1
AA1000	No.2 fixing brackets wall side-by-side structures	1
ED2969	4P busbar 24 modules	3
ED3132	Feeder+cable l=350mm 4P 100A	1
GD1520	DIN rail, pitch 150/200mm	3
ED3090	Feeder+cable l=600mm parallel 4P 100A	2
TL2000	Scaled crosspiece x cable container	4
PB0802	Scaled busbar holder In=800A (35 kA)	2
BA0400	Busbar In=400A	2
KB1002	Connections T3 floor/wall	1
ED2183	Frame with busbars 24 modules	1
AD1097	Unifix H fixing brackets	1
AD1064	No.12 joining screws l=27 x flat busbars up to 10mm	1
AD1098	No.4 floor wiring duct supports	2

(*) For selection of the connection according to the circuit-breaker, see page 3/15.

ArTu L modular structures

Examples of configuration

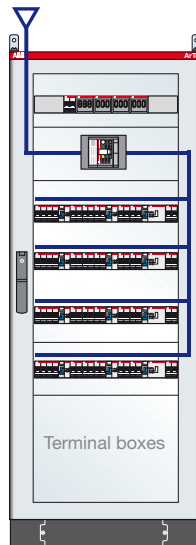

ArTu L Series dim. 1800x600x195 (1950x690x240) mm (external hxwxd) IP43 with plate for Tmax T3 and modular panels

Code	Description	Q.ty
SL1800	Back structure 1800x700x240mm (hxwxd)	1
MC1800	Blind riser h=1800mm	1
ZL1000	Base strips x structure	1
ZL1001	Structure flanges	1
PV1800	Glass door x structure h=1800mm	1
LK3000	T3 floor/wall Kit horiz. 3/4P	1
PC2600	Plain panel 200x600mm (hwx) M, K	1
PC4600	Plain panel 400x600mm (hwx) M, K	1
PM2624	Panel 24 mod. 200x600mm (hwx) M, K	2
PM6672	Panel 72 mod. 600x600mm (hwx) M, K	1
AL2000	N°2 wall fixing brackets L	1
GD1520	DIN rail, pitch 150/200mm	5
AD1098	N °4 supports for horiz./vert. floor-standing wiring duct	2

ArTu L Series dim. 1800x600x195 (1950x690x240) mm (external hxwxd) IP43 with plate for Tmax XT3 and modular panels

Code	Description	Q.ty
SL1800	Back structure 1800x700x240mm (hxwxd)	1
MC1800	Blind riser h=1800mm	1
ZL1000	Base strips x structure	1
ZL1001	Structure flanges	1
PV1800	Glass door x structure h=1800mm	1
LX3000	XT3 floor/wall Kit horiz. 3/4P	1
PC2600	Plain panel 200x600mm (hwx) M, K	1
PC4600	Plain panel 400x600mm (hwx) M, K	1
PM2624	Panel 24 mod. 200x600mm (hwx) M, K	2
PM6672	Panel 72 mod. 600x600mm (hwx) M, K	1
AL2000	No.2 wall fixing brackets L	1
GD1520	DIN rail, pitch 150/200mm	5
AD1098	No.4 supports for horiz./vert. floor-standing wiring duct	2

3

ArTu L modular structures

Distribution systems

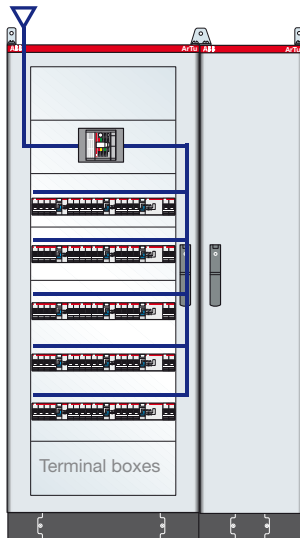

ArTu L Series dim. 1800x900x195 (1950x1080x240) mm (external hxwxd) IP43 complete with cable container l=300mm, plate for Tmax T3 and modular panels

Code	Description	Q.ty
SL1800	Back structure 1800x700x240mm (hxwxd)	1
MC1800	Blind riser h=1800mm	1
ZL1000	Base strips x structure	1
ZL1001	Structure flanges	1
PV1800	Glass door x structure h=1800mm	1
LK3000	T3 floor/wall Kit horiz. 3/4P	1
PC2600	Plain panel 200x600mm (hwx) M, K	1
PC4600	Plain panel 400x600mm (hwx) M, K	1
PM2624	Panel 24 mod. 200x600mm (hwx) M, K	2
PM6672	Panel 72 mod. 600x600mm (hwx) M, K	1
AL2000	N°2 wall fixing brackets L	1
ZL3000	Base strips x side-by-side assembly	1
ZL2001	Cable container flanges	1
VC1800	Cable container h=1800mm	1
PO1831	Blind door 1800x300mm (hwx) L, M int.	1
PC1802	Blind door x cable container h=1800mm	1
MI1800	Riser CB side-by-side structures h=1800mm	1
AA1000	N°2 fixing brackets wall side-by-side structures	1
GD1520	DIN rail, pitch 150/200mm	5
AD1098	N °4 supports for horiz./vert. floor-standing wiring duct	3

ArTu L Series dim. 1800x900x195 (1950x1080x240) mm (external hxwxd) IP43 complete with cable container l=300mm, plate for Tmax XT3 and modular panels

Code	Description	Q.ty
SL1800	Back structure 1800x700x240mm (hxwxd)	1
MC1800	Blind riser h=1800mm	1
ZL1000	Base strips x structure	1
ZL1001	Structure flanges	1
PV1800	Glass door x structure h=1800mm	1
LX3000	XT3 floor/wall Kit horiz. 3/4P	1
PC2600	Plain panel 200x600mm (hwx) M, K	1
PC4600	Plain panel 400x600mm (hwx) M, K	1
PM2624	Panel 24 mod. 200x600mm (hwx) M, K	2
PM6672	Panel 72 mod. 600x600mm (hwx) M, K	1
AL2000	No.2 wall fixing brackets L	1
ZL3000	Base strips x side-by-side assembly	1
ZL2001	Cable container flanges	1
VC1800	Cable container h=1800mm	1
PO1831	Blind door 1800x300mm (hwx) L, M int.	1
PC1802	Blind door x cable container h=1800mm	1
MI1800	Riser CB side-by-side structures h=1800mm	1
AA1000	No.2 fixing brackets wall side-by-side structures	1
GD1520	DIN rail, pitch 150/200mm	5
AD1098	No.4 supports for horiz./vert. floor-standing wiring duct	3

ArTu L modular structures

Examples of configuration

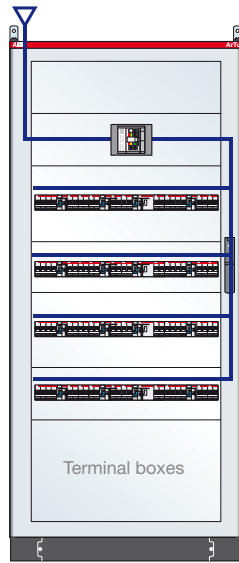

ArTu L Series dim. 1800x800x195 (1950x890x240) mm (external hxwxd) IP43 complete with internal cable container w=200mm

Code	Description	Q.ty
SL1808	Back structure 1800x800x195mm (hxwxd)	1
MC1800	Blind riser h1800	1
ZL1000	Base strips x structure	1
ZL1101	Structure flanges w=800mm	1
PV1836	Glass door x structure 1800x800mm 36mod	1
LK3110	T3 floor/wall Kit horiz. 3/4P	1
PC2800	Blind panel 200x800 (hxw)	1
PC4800	Blind panel 400x800 (hxw)	1
PM2836	Panel 36 mod. 200x800	2
PM3872	Panel mod. h=300 l=800 pitch 150mm	2
AL2000	N°2 wall fixing brackets	1
GD1530	DIN rail, pitch 150/200mm w=36 mod.DIN	4
EV1110	N°50 angled supports 1 row of terminals	1
EV1119	N°2 busbars 20x5 mm drilled and threaded M6 W=2000mm	1

ArTu L Series dim. 1800x800x195 (1950x890x240) mm (external hxwxd) IP43 complete with internal cable container w=200mm

Code	Description	Q.ty
SL1808	Back structure 1800x800x195mm (hxwxd)	1
MC1800	Blind riser h1800	1
ZL1000	Base strips x structure	1
ZL1101	Structure flanges w=800mm	1
PV1836	Glass door x structure 1800x800mm 36mod	1
LX3110	Kit floor XT3 Kit horiz. 3/4P	1
PC2800	Blind panel 200x800 (hxw)	1
PC4800	Blind panel 400x800 (hxw)	1
PM2836	Panel 36 mod. 200x800	2
PM3872	Panel mod. h=300 l=800 pitch 150mm	2
AL2000	No.2 wall fixing brackets	1
GD1530	DIN rail, pitch 150/200mm w=36 mod.DIN	4
EV1110	No.50 angled supports 1 row of terminals	1
EV1119	No.2 busbars 20x5 mm drilled and threaded M6 W=2000mm	1

3

ArTu L modular structures

Distribution systems

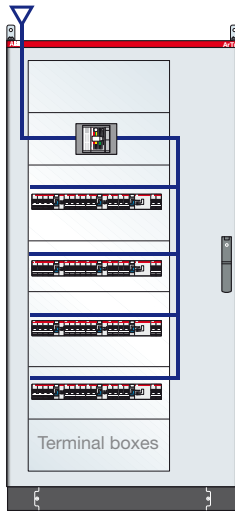

ArTu L Series dim.1600x800x195 (1750x890x240)mm (external hxwxd) IP43 complete with internal cable container w=200mm, plate for Tmax T3, and modular panels

Code	Description	Q.ty
SL1608	Back structure 1600x800x195mm (hxwxd)	1
ZL1000	Base strips x structure	1
ZL1101	Structure flanges w =800mm	1
MC1600	Blind riser h1600	1
PV1624	Glass door x structure 1600x800mm 24mod	1
VC1625	Int. cable container h=1600mm	1
LK3000	T3 floor/wall Kit horiz. 3/4P	1
PM3624	Panel 24 mod. 300x600	2
PM2624	Panel 24 mod. 200x600	2
PC2600	Blind panel 200x600	2
AL2000	N °2 wall fixing brackets	1
GD1520	DIN rail, pitch 150/200mm	4

ArTu L Series dim.1600x800x195 (1750x890x240)mm (external hxwxd) IP43 complete with internal cable container w=200mm, plate for Tmax T3, and modular panels

Code	Description	Q.ty
SL1608	Back structure 1600x800x195mm (hxwxd)	1
ZL1000	Base strips x structure	1
ZL1101	Structure flanges w =800mm	1
MC1600	Blind riser h1600	1
PV1624	Glass door x structure 1600x800mm 24mod	1
VC1625	Int. cable container h=1600mm	1
LX3000	XT3 floor/wall Kit horiz. 3/4P	1
PM3624	Panel 24 mod. 300x600	2
PM2624	Panel 24 mod. 200x600	2
PC2600	Blind panel 200x600	2
AL2000	No.2 wall fixing brackets	1
GD1520	DIN rail, pitch 150/200mm	4

ArTu L modular structures

Examples of configuration

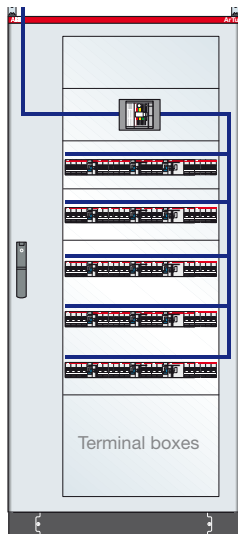

ArTu L Series dim.1800x800x195 (1950x890x240)mm (external hxwxd) IP43 complete with internal cable container w =200mm, plate for Tmax T3 and modular panels

Code	Description	Q.ty
SL1808	Back structure 1900x800x195mm (hxwxd)	1
MC1800	Blind riser h1800	1
ZL1000	Base strips x structure	1
ZL1101	Structure flanges w=800mm	1
PV1824	Glass door x structure 1800x800mm 24mod	1
LK3000	T3 floor/wall Kit horiz. 3/4P	1
PC2600	Blind panel 200x600	1
PC4600	Blind panel 400x600	1
PM2624	Panel 24 mod. 200x600	2
PM6672	Panel 74 mod. 600x600	1
AL2000	N °2 wall fixing brackets	1
VC1825	Internal cable container h=1800mm	1
GD1520	DIN rail, pitch 150/200mm	5

ArTu L Series dim.1800x800x195 (1950x890x240)mm (external hxwxd) IP43 complete with internal cable container w =200mm, plate for Tmax T3 and modular panels

Code	Description	Q.ty
SL1808	Back structure 1900x800x195mm (hxwxd)	1
MC1800	Blind riser h1800	1
ZL1000	Base strips x structure	1
ZL1101	Structure flanges w=800mm	1
PV1824	Glass door x structure 1800x800mm 24mod	1
LX3000	XT3 floor/wall Kit horiz. 3/4P	1
PC2600	Blind panel 200x600	1
PC4600	Blind panel 400x600	1
PM2624	Panel 24 mod. 200x600	2
PM6672	Panel 74 mod. 600x600	1
AL2000	No.2 wall fixing brackets	1
VC1825	Internal cable container h=1800mm	1
GD1520	DIN rail, pitch 150/200mm	5



Index

General	4/2
Selection of the structure	4/4
Kit for installing apparatus.....	4/7
Distribution systems.....	4/12
Examples of configurations.....	4/17

ArTu M monobloc structures

General

The ArTu M switchgear offers a simple and functional solution for constructing secondary and terminal distribution switchgear for uses where the degree of protection is important.

It can be wall or floor-mounted, only requiring assembly of the front door and side panels thanks to their characteristic monobloc structure.



Within the series, the wall-mounted switchgear is preset for installation of System Pro M modular apparatus and Tmax T1, T2 and T3 T series up to T3 250 A, XT series up to XT3, (fixed version with front terminals) moulded-case circuit-breakers up to 250A and the Unifix wiring system.

The wall-mounted models include two depths (150 and 200mm), a functional width of 24 DIN modules (600 mm) and four different heights (600, 800, 1000 and 1200 mm), corresponding to 3, 4, 5 and 6 DIN rows with 200 mm centre

Technical characteristics

	Wall-mounted D=115/165	Floor-mounted D=195
Compliance with Standards	CEI EN 60439-1/IEC 61439-1-2	
Rated service voltage U_e	up to 690 V	
Rated insulation voltage U_i	up to 1000 V	
Frequenza nominale	50-60 Hz	
Rated impulse withstand voltage U_{imp}	6 kV	8 kV
Rated current I_n	up to 250 A	up to 630 A
Rated short-time short-circuit withstand current I_{cw}	up to 25 kA	up to 35 kA
Rated peak short-circuit current I_{pk}	up to 52,5 kA	up to 74 kA
Degree of protection IP	65 with door	31 without door 65 with door

ArTu M monobloc structures

General

distance.

It is also possible to use the 150 mm centre distance, thereby considerably increasing the internal capacity, which reaches 4, 5, 6 and 8 DIN rows respectively.

The floor-mounted switchgear, on the other hand, has a depth of 250 mm and is available in two functional widths (600 mm 24 DIN modules and 800 mm 36 DIN modules or 24 DIN modules plus cable riser) in four heights (1400, 1600, 1800 and 2000 mm), corresponding to 7, 8, 9 and 10 DIN rows respectively, with 200 mm centre distance. Again in this case it is possible to use the 150 mm centre distance to increase the internal capacity, taking this to 9, 10, 12 and 13 DIN rows respectively.

The modular System Pro M, and the Tmax up to T6 T serie up to T6 800 A, XT series up to XT4, (fixed version with front terminals) moulded-case circuit-breakers in the fixed version with front terminals are found within the floor-mounted version. The busbar systems with shaped section up to 800A, flat up to 630A and the Unifix cabling system can be used. The sides of the M series floor-mounted switchgear consist of two removable side panels, which allow lateral coupling of the structures or cable containers with useful width of 300mm.

The front door, available either made of transparent tempered glass applied from the inside, or of plain steel sheet, can be replaced according to the different application requirements by finishing frames with IP 31 degree of protection. It is also possible to carry out fixing to the wall using dedicated brackets for the floor-mounted versions.

The 100 mm high base strip, complete with removable flanges, is already mounted on the structure, and allows easy handling with transpallets. Removable flanges for conductor inlet are also provided in the top and bottom area.

The maximum rated current is 630 A and the degree of protection varies from IP31 (without front door) to IP65 (with front door).

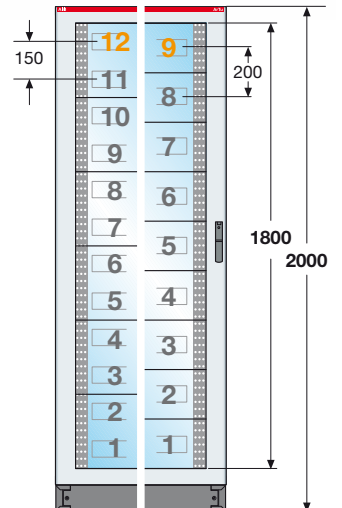

ArTu M monobloc structures

Selection of the structure

Structure

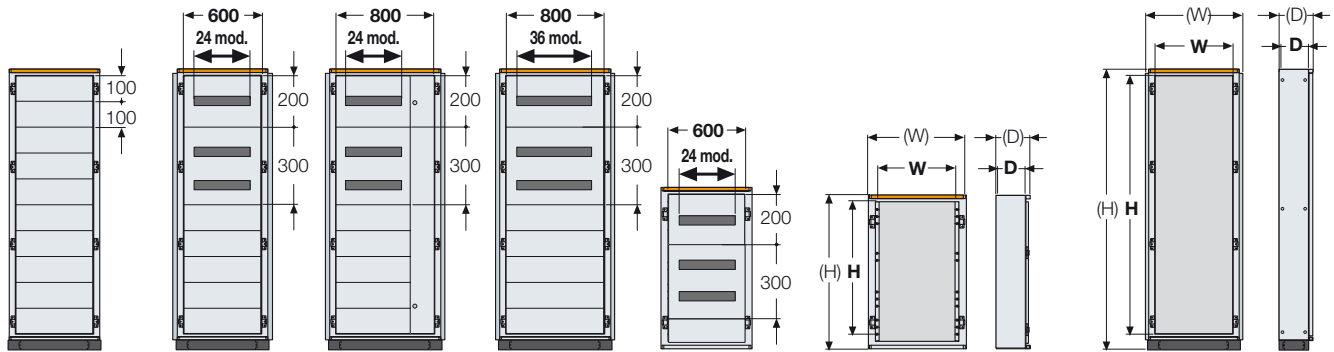

N° vert. mod. H=100mm	N° of DIN mod. which can be installed		Overall external dimensions ⁽¹⁾			Functional dimensions ⁽²⁾			Wall structures	Floor structures
	DIN panel 150 mm centre dist.	DIN panel 200 mm centre dist.	(H) mm	(W) mm	(D) ⁽³⁾ mm	H mm	W mm	D ⁽³⁾ mm	Basic version	
6	96 (24x4)	72 (24x3)	700	700	150	600	600	115	SM6061	-
8	120 (24x5)	96 (24x4)	900	700	150	800	600	115	SM8061	-
				700	200		600	165	SM8062	-
10	144 (24x6)	120 (24x5)	1100	700	200	1000	600	165	SM1062	-
12	192 (24x8)	144 (24x6)	1300	700	200	1200	600	165	SM1262	-
14	216 (24x9)	168 (24x7)	1596	724	250	1400	600	195	-	SM1462
16	240 (24x10)	192 (24x8)	1796	724	250	1600	600	195	-	SM1662
	360 (36x10)	288 (36x8)		924	250		800		195	-
18	288 (24x12)	216 (24x9)	1996	724	250	1800	600	195	-	SM1862
	432 (36x12)	324 (36x9)		924	250		800		195	-
20	313 (24x13)	240 (24x10)	2196	724	250	2000	600	195	-	SM2062
	468 (36x13)	360 (36x10)		924	250		800		195	-

The cable container, placed at the side of the structure with the special kit (AD1012), keeps the IP65 degree of protection when installed with an external door.

The external doors are used on the additional cable container to be placed side by side with an ArTu structure with door (IP65). The internal doors are used on the additional cable container placed side by side with an ArTu structure in the IP31 version (i.e. without door and with finishing profiles). This ensures uniformity of appearance between the structure and additional cable container.

Furthermore, the internal doors can be used as internal segregations of the cable container: should a segregation with door of the additional cable container open be requested, it is possible to mount both the internal and external door at the same time.

Additional cable container W = 300mm

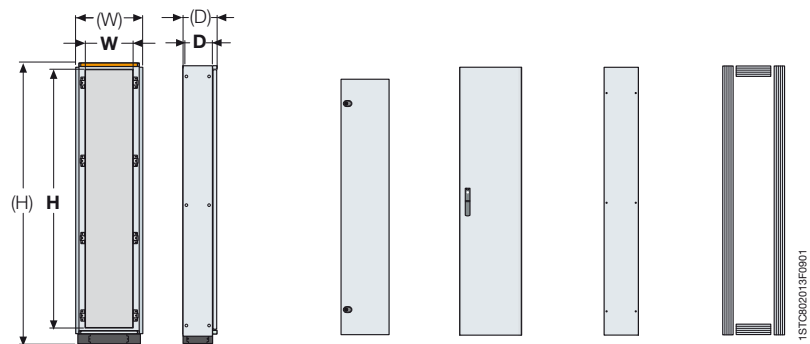

Overall external dimensions ⁽¹⁾			Functional dimensions ⁽²⁾			Structure	Internal door front IP31	External door front IP65	Side panel	Finishing section IP31
(H) mm	(W) mm	(D) ⁽³⁾ mm	H mm	W mm	D ⁽³⁾ mm					
1796	424	250	1600	300	195	VC1632	PO1631	PO1630	LF1625	See page 9/35
1996	424	250	1800	300	195	VC1832	PO1831	PO1830	LF1825	
2196	424	250	2000	300	195	VC2032	PO2031	PO2030	LF2025	

ArTu M monobloc structures

Selection of the structure

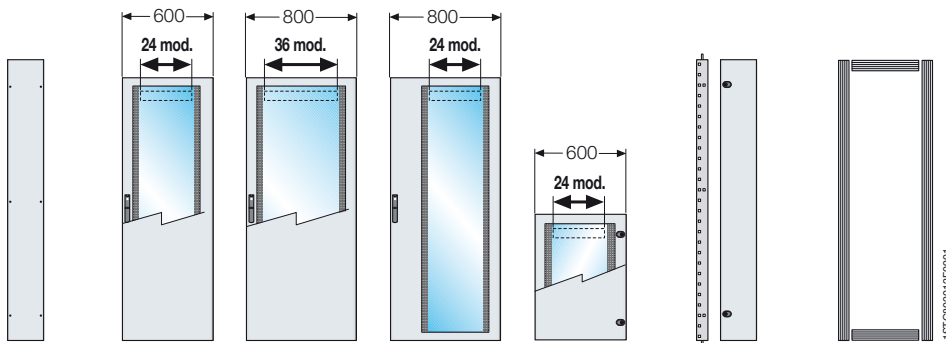

- (1) The overall dimensions of the ArTu M switchgear starting from the 1400mm (1596mm) height include the base strip h=100mm and the side panels.
- (2) The functional dimensions represent the useful space for installing the apparatus.
- (3) In this catalogue, reference is always made to the 150/200/250mm depths corresponding to the external overall dimensions with front door. The useful dimensions between panel and bottom of the structure are 115/165/195 mm.

Side covering IP65	Front doors IP65		Internal cable container	Finishing section IP31
Side panel	Glass door 24/36 mod.	Glass door 24 mod.+ int cable container	Blind door 24/36 mod.	
-	PV6060	-	PO6060	-
-	PV8060	-	PO8060	-
-	PV8060	-	PO8060	-
-	PV1060	-	PO1060	-
-	PV1260	-	PO1260	-
LF1425	PV1460	-	PO1460	-
LF1625	PV1660	-	PO1660	-
LF1625	PV1688	PV1680	PO1680	VC1622
LF1825	PV1860	-	PO1860	-
LF1825	PV1888	PV1880	PO1880	VC1822
LF2025	PV2060	-	PO2060	-
LF2025	PV2088	PV2080	PO2080	VC2022

- (4) The QSO switchgear for operating theatres is complete with brackets (AD1009 n° 4 pieces) for installation of the wiring duct, two DIN rail kits (GD6001 and PM2624 n° 2 pieces) and relative brackets for wall fixing (4 pieces). The switchgear can be fitted with the Yale type key box with unique numbering (AA8002).

4

Structure for constructing IP40 switchgear for operating theatres

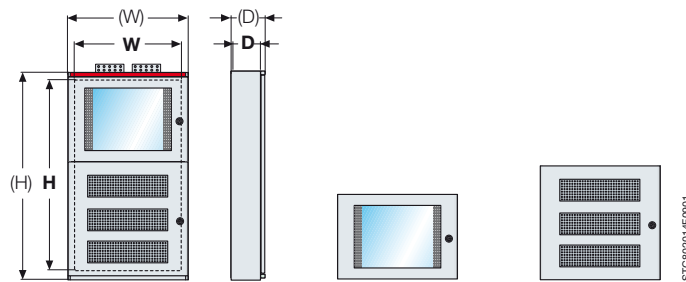

Overall external dimensions ⁽¹⁾			Functional dimensions ⁽²⁾			Complete structure ⁽⁴⁾	Spare parts	
(H) mm	(W) mm	(D) ⁽³⁾ mm	H mm	W mm	D ⁽³⁾ mm		Glass door	Blind door
1100	700	200	1000	600	165	SM1069	PV4060	PO6069

ArTu M monobloc structures

Selection of the structure

Solutions recommended for installation of the apparatus

Apparatus	Type of structure/Installation					
	Wall-mounted structures			Floor-mounted structures		
	Vertical on DIN rail	Vertical	Horizontal	Vertical on DIN rail	Vertical	Horizontal
System Pro M modular apparatus	•			•		
OT				•	•	
OESA					•	
OETL					•	
Tmax T1 3/4 poles - fixed / front terminals	•			•		•
Tmax T1 4 poles - fixed / front terminals +diff. mod.	• ⁽¹⁾			•		
Tmax T2 3/4 poles - fixed / front terminals	•			•		•
Tmax T2 4 poles - fixed / front terminals +diff. mod.	• ⁽¹⁾			•		
Tmax T3 3/4 poles - fixed / front terminals	•		•	•		•
Tmax T3 4 poles - fixed / front terminals +diff. mod.	• ⁽¹⁾			•	•	•
Tmax T4 3/4 poles - fixed / front terminals					•	•
Tmax T4 4 poles - fixed / front terminals +diff. mod.					•	•
Tmax T5 3/4 poles - fixed / front terminals					•	•
Tmax T5 4 poles - fixed / front terminals +diff. mod.					•	•
Tmax T6 3/4 poles - fixed / front terminals					•	•
Busbar with shaped section Linear busbar holder					(◉)	
Flat busbar Scaled busbar holder					(■)	
Unifix L Linear busbar holder					•	
Unifix H			(◉)			(◉)
Tmax XT1 3/4 poles - fixed / front terminals	•			•	•	•
Tmax XT1 4 poles - fixed / front terminals + diff. mod.	• ⁽¹⁾			•	•	•
Tmax XT2 3/4 poles - fixed / front terminals						•
Tmax XT2 4 poles - fixed / front terminals + diff. mod.						•
Tmax XT3 3/4 poles - fixed / front terminals	•		•	•	•	•
Tmax XT3 4 poles - fixed / front terminals + diff. mod.	• ⁽¹⁾			•	•	•
Tmax XT4 3/4 poles - fixed / front terminals					•	•
Tmax XT4 4 poles - fixed / front terminals + diff. mod.					•	•
Side-by-side Tmax XT kits					•	

⁽¹⁾ Only for structures D=200mm.

(◉) Can only be installed in the structure.

(■) Can only be installed in the cable container.

Wall-mounted ArTu

Assembly solution

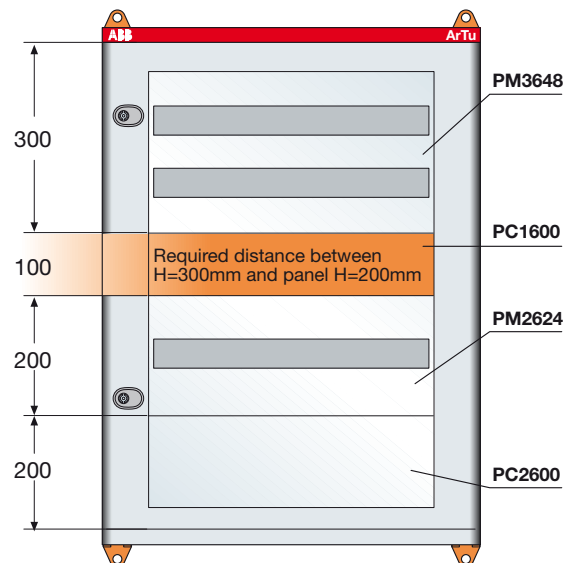
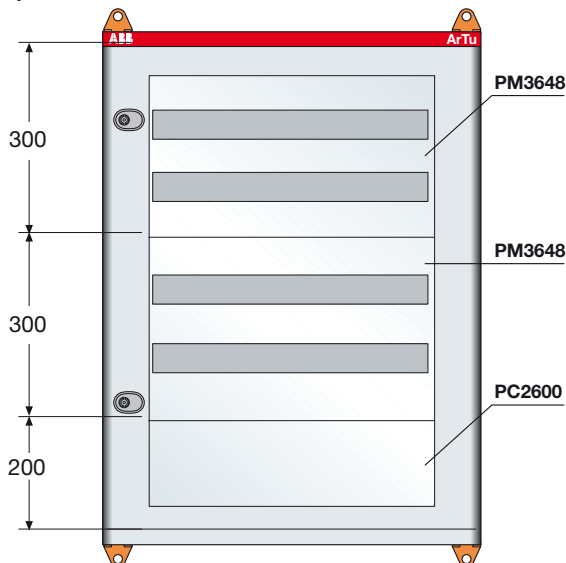

Side-by-side assembly between a H=300mm and a H=200mm modular panels is not allowed

ArTu M monobloc structures

Kit for installing apparatus

System Pro M modular apparatus, Tmax T1-T2-T3, XT1 and XT3, OT_≤ 160 and supports for Unifix H

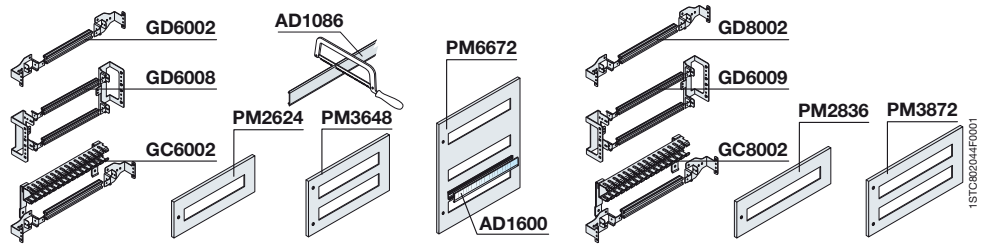

H (mm)	W=600mm				W=800mm		
	DIN rail kit 24 DIN mod.	Panel 1 DIN row 24 DIN mod.	Panel 2 DIN rows 48 DIN mod.	Panel 3 DIN rows 72 DIN mod.	DIN rail kit 36 DIN mod.	Panel 1 DIN row 36 DIN mod.	Panel 2 DIN rows 72 DIN mod.
Standard aluminium version							
200	GD6002	PM2624			GD8002	PM2836	
300⁽¹⁾	GD6002	PM2312			GD8002	PM2315	
300	GD6008		PM3648		GD6009		PM3872
600	3x GD6002			PM6672			
Version fitted with accessories (complete with 60x80 wiring duct and AD 1037 supports)							
200	GC6002	PM2624			GC8002	PM2836	
Reinforced version for Tmax and Tmax differential RC 222/1 mod. 200mm							
200	GD6010 ⁽¹⁾	PM2624			GD8010	PM2836	
Reinforced version Tmax + differential module⁽²⁾							
300	GD6010 ⁽¹⁾	PM2312			GD8010	PM2315	
Unifix H fixing brackets							
300	AD1061	PM3624			AD1061	PM3836	

⁽¹⁾ Cannot be installed on wall-mounted version.
⁽²⁾ Version for Tmax with differential module underplaced RC 221/222.

Completion items for installation on DIN rail

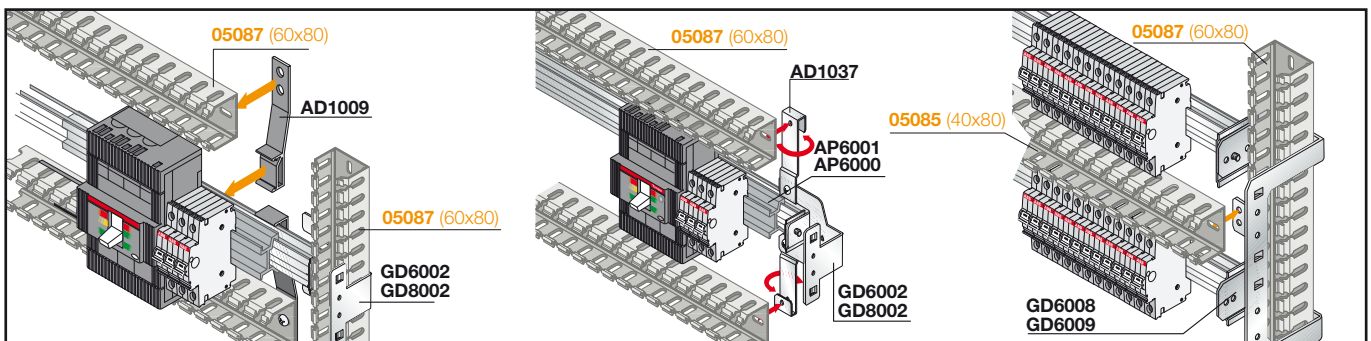

Supports for horizontal wiring duct

Code	Description
AD1009	Horizontal wiring duct (plastic) supports
AD1037	Horizontal wiring duct (metal) supports

Allows assembly of the cabling wiring duct horizontally up to 60x80mm. The AD1009 plastic model can be positioned on the rear of the DIN rail, whereas the AD1037 metal version is fixed onto the brackets of DIN rail GD6002/ GD8002, and allows adjustment of the wiring duct depth.

Depth adapter

Code	Description
AP6000	N°1 depth adapter for Tmax T1-T2-T3-XT1-XT3 W=600mm floor-standing
AP6001	N°1 depth adapter for Tmax T1-T2-T3-XT1-XT3 W=600mm wall-mounting

DIN window hole covers

Code	Description
AD1086	DIN L=2000mm hole cover strip - grey RAL 7035
AD1088	DIN 24 modules hole cover strip - grey RAL 7035
AD1089	DIN 36 modules hole cover strip - grey RAL 7035

Tmax XT Flanges for DIN-Rail mounting

Code	Description
AD3301	XT1 3P Flange for DIN-Rail mounting
AD3302	XT1 4P Flange for DIN-Rail mounting
AD3303	XT3 3P Flange for DIN-Rail mounting
AD3304	XT3 4P Flange for DIN-Rail mounting

Already supplied in the DIN-Rail mounting kit for breakers in MCCBs catalogue 1SDC210033D0901

For Isomax kits, please see page 9/83.

ArTu M monobloc structures

Kit for installing apparatus

Horizontal installation

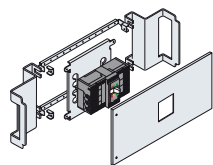

Circuit-breaker front terminals	N° poles	Dimensions H (mm)	Fixed		Fixed + diff. mod. underneath	
			24 DIN mod. W=600mm	36 DIN mod. W=800mm	24 DIN mod. W=600mm	36 DIN mod. W=800mm
Tmax T1	3-4	200	KT1117			
Tmax T1	4	200			KT1102⁽¹⁾	
Tmax T2	3-4	200	KT2117			
Tmax T2	4	200			KT2102	KL2103
Tmax T3	3-4	200	KT3112	KL3113		
Tmax T3	4	300			KT3102	KL3103
Tmax T3	3-4	200	KT3118⁽¹⁾			
Tmax T4	3-4	200	KT4112	KL4115		
Tmax T4	4	200			KT4110	KL4116
Tmax T5	3-4	300	KT5112	KL5114		
Tmax T5	4	300			KT5110	KL5116
Tmax T6	3-4	500	KT6113	KL6113		
Tmax XT1	3 ⁽²⁾ /4	200	KX1617			
Tmax XT1 CB + diff. mod.	4	200			KX1602	
Tmax XT2	3 ⁽²⁾ /4	200	KX2619			
Tmax XT2 CB + diff. mod.	4	200			KX2602	
Tmax XT3	3 ⁽²⁾ /4	200	KX3612	KL3613		
Tmax XT3	3 ⁽²⁾ /4	200	KX3618 (1)			
Tmax XT3 CB + diff. mod.	4	300			KX3602	KX3603
Tmax XT4	3 ⁽²⁾ /4	200	KX4612	KX4615		
Tmax XT4 CB + diff. mod.	4	200			KX4610	

⁽¹⁾ Version for Tmax with differential module underplaced RC 221/222

⁽²⁾ For 3 poles breakers please order accessory flange codes: **AD3305** XT1 3P Flange for plate-mounting - **AD3306** XT2 3P Flange for plate-mounting - **AD3307** XT3 3P Flange for plate-mounting - **AD3308** XT4 3P Flange for plate-mounting

Vertical installation

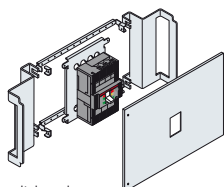

Circuit-breaker front terminals	N° poles	Dimensions H (mm)	Fixed		Fixed + diff. mod. underneath	
			24 DIN mod. W=600mm	36 DIN mod. W=800mm	24 DIN mod. W=600mm	36 DIN mod. W=800mm
Tmax T1-T2-T3 on DIN 35 rail		200	(see page 4/7)			
Tmax T3	3-4	300	KT3212			
Tmax T4	3-4	400	KT4212			
Tmax T4	4	500			KT4102	
Tmax T5	3-4	400	KT5212	KL5212		
Tmax T5	3-4	500			KT5102	KL5102
Tmax T6	3-4	500	KT6213	KL6213		
Tmax XT1	3 ⁽²⁾ /4	200	KX1618			
Tmax XT1 CB + diff. mod.	4	300			KX1603	
Tmax XT1 N 3 CBs side by side	3 ⁽²⁾ /4	200	KX1604			
Tmax XT3	3 ⁽²⁾ /4	300	KX3614			
Tmax XT3 CB + diff. mod.	4	300			KX3609	
Tmax XT4	3 ⁽²⁾ /4	300	KX4614			
Tmax XT4 CB + diff. mod.	4	400			KX4602	

Hole cover W=2000mm Article AD1086, 24 DIN modules AD1088, 36 DIN modules AD1088, colour grey RAL 7035.

⁽¹⁾ Kit for wall-mounted ArTu M D=200mm.

⁽²⁾ For 3 poles breakers please order accessory flange codes: **AD3305** XT1 3P Flange for plate-mounting - **AD3306** XT2 3P Flange for plate-mounting - **AD3307** XT3 3P Flange for plate-mounting - **AD3308** XT4 3P Flange for plate-mounting

For Isomax kits, please see page 9/83.

Selection by componentspage 9/12

In-depth technical informationpage 6/10

Overall dimensionspage 8/10

ArTu M monobloc structures

Kit for installing apparatus

Plain back plates, plain and ventilated panels

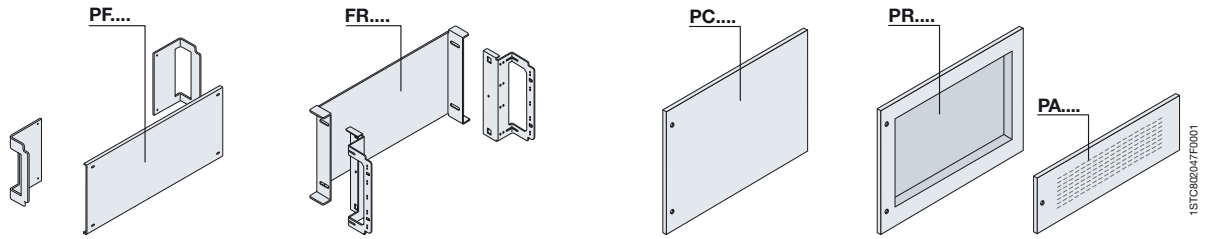

H (mm)	Back plates				Panels					
	Plain flat		Plain recessed		Plain flat		Plain recessed		Ventilated	
	24 DIN mod. W=600mm	36 DIN mod. W=800mm	24 DIN mod. W=600mm	36 DIN mod. W=800mm	24 DIN mod. W=600mm	36 DIN mod. W=800mm	24 DIN mod. W=600mm	36 DIN mod. W=800mm	24 DIN mod. W=600mm	
100					PC1600	PC1800			PA1600	
200	PF2610 ⁽¹⁾	PF2810	FR2601	FR2801	PC2600	PC2800	PR2600	PR2800	PA2600	
300					PC3600	PC3800				
400	PF4610	PF4810	FR4601	FR4801	PC4600	PC4800	PR4600	PR4800		
600					PC6600	PC6800	PR6600	PR6800		
800					PC8600	PC8800				
1600					PC1660	PC1680				
1800					PC1860	PC1880				
2000					PC2060	PC2080				

⁽¹⁾ Can also be installed on wall-mounted Artu M version. Can be used to mount all the non-modular apparatus. For useful dimensions, please see page 8/20.

Kit for OT200/250/315/400

vertical installation

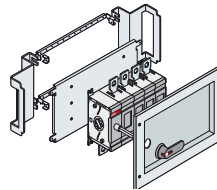

horizontal installation

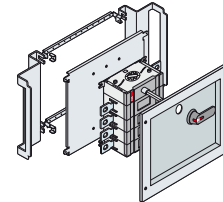

H (mm)	Width structure (mm)	OT200/250 OT315/400	OT125/160	OT200/250 OT315/400
300	600	KO2260	KO1201	KO2261
300	800	KO2280		KO2281

Useful internal space

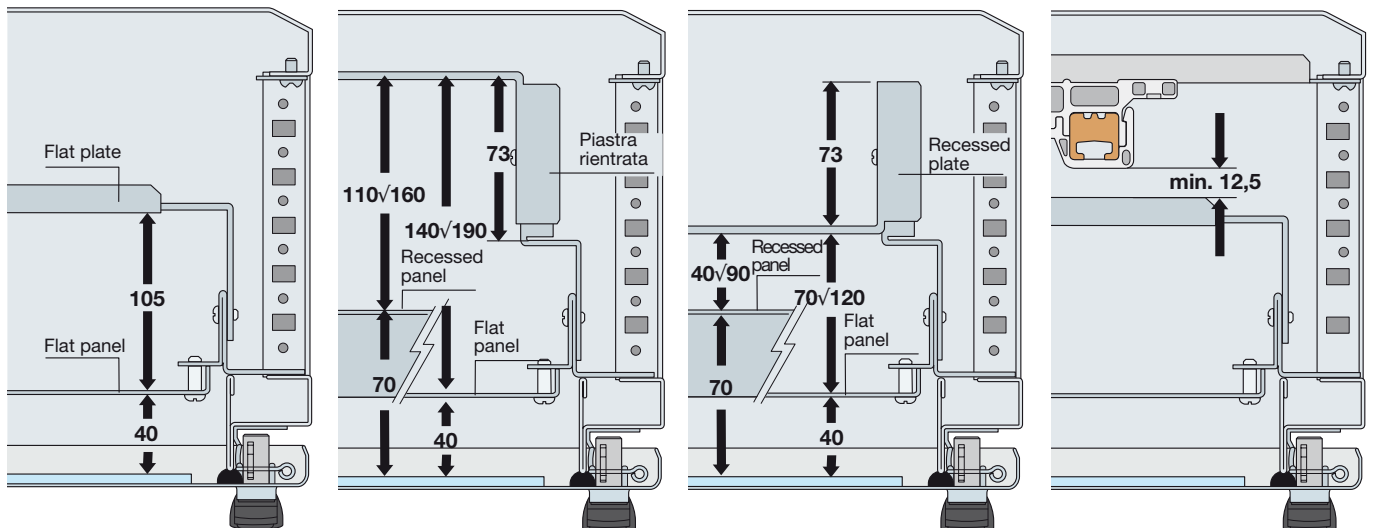

ArTu M monobloc structures

Kit for installing apparatus

Panels for square measuring instruments

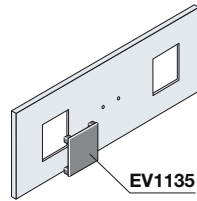

2-instrument panel

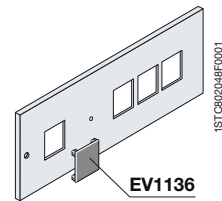

4-instrument panel

H (mm)	72x72mm		96x96mm		72x72mm		96x96mm	
	24 DIN mod. W=600mm	36 DIN mod. W=800mm	24 DIN mod. W=600mm	36 DIN mod. W=800mm	24 DIN mod. W=600mm	36 DIN mod. W=800mm	24 DIN mod. W=600mm	36 DIN mod. W=800mm
200	PS2720	PS2728	PS2960	PS2968	PS4720	PS4728	PS4960	PS4968

These allow installation of measuring instruments and relative changeover switches.

Square instrument hole covers

Code	Description
EV1135	Hole cover of 72x72mm instrument black RAL 9005
EV1136	Hole cover of 96x96mm instrument black RAL 9005

Installation of terminal boxes on DIN rail

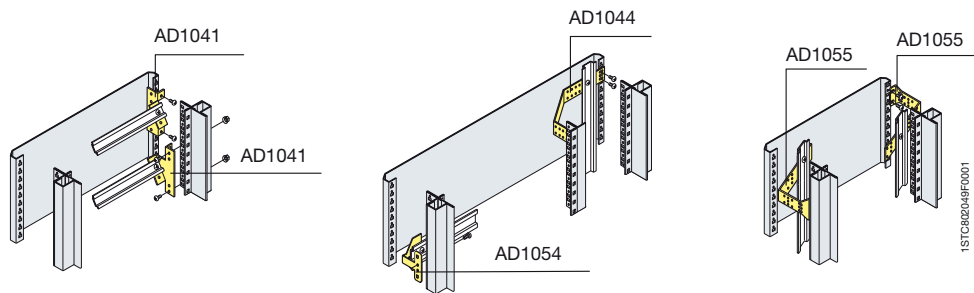

Terminal box mounting position

Installation on DIN rail

Horizontal
Horizontal angled 45°
Vertical

Structure	Internal cable container	External cable container
AD1054		
AD1041		
	AD1044	AD1055

The ArTu switchgear is preset for assembly of terminal boxes with the sole exception of the models in the M wall-mounted series with 150mm depth.

Installation of terminal boxes on DIN rail and earthing busbar

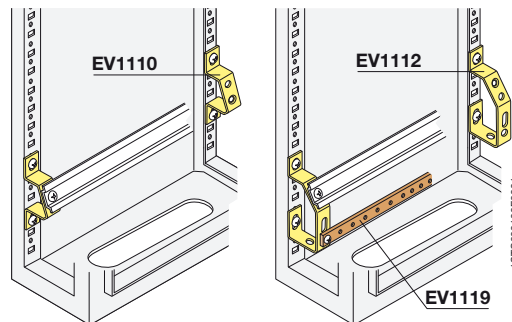

Angled supports for terminal boxes and earthing busbar

Code	Description
EV1110	Angled supports 1 row of terminals
EV1112	Angled supports 1 row of terminals + earth

ArTu M monobloc structures

Distribution systems

Modular dividers

Single-pole

Three-poles

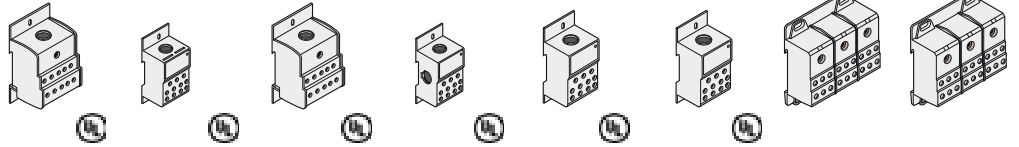

Code	AD1076	AD1080 ⁽¹⁾	AD1007	AD1081 ⁽²⁾	AD1030	AD1031	AD1075	AD1006
In (A)	125	125	160	160	250	400	125	160
Icw (kA)	4.2	4.2	11	11	21	21	11	4.2
Version poli	1	1	1	1	1	1	3	3
Installation	DIN35/plate	DIN35/plate	DIN35/plate	DIN35/plate	DIN35/plate	DIN35/plate	DIN35/plate	DIN35/plate
Power supply Ø cable (mm²)	min. 10 max. 35	min. 6 max. 35	min. 16 max. 70	min. 10 max. 70	min. 35 max. 120	min. 95 max. 185	min. 10 max. 35	min. 16 max. 70
N°outgoing feeder Ø cable (mm²)	2,5÷10 2,5÷16 2,5÷25 2,5÷35	10 6	10	6	4 5 2	4 5 2	6	6
Dimensions HxWxD (mm)	71x45x42,5	75x25x47	71x45x42,5	92x35x49	96x45x49	96x45x49	80x71,5x42,5	80x71,5x42,5
N° DIN modules	2,5	1,5	2,5	2	3	3	4,5	4,5
Rated service voltage Ue (V)	690	500	690	500	500	500	690	690
Degree of protection IP	20	20	20	20	20	20	20	20

Four-poles

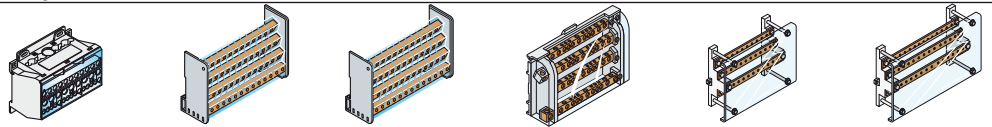

Code	AD1004	AD1028	AD1029	AD1027	AD1034	AD1053
In (A)	125	125	125	160	250	250
Icw (kA)	4.2	4.2	4.2	6.2	15	15
Version poles	4	4	4	4	4	4
Installation	DIN35/plate	DIN35/plate	DIN35/plate	DIN35	with AD1038 brackets	with AD1038 brackets
Power supply Ø cable (mm²)	min. 6 max. 35	min. 6 max. 25 with cable terminal 35 without cable terminal	min. 6 max. 25 with cable terminal 35 without cable terminal	min. 10 max. 50		
N°outgoing feeder Ø cable (mm²)	5 holes/phase Ø1÷6 2 holes/phase Ø1,5÷16 6 holes/neutral Ø1,5÷16 4 holes/neutral Ø1,5÷6 ²	2xØ6÷25 + cable terminal 2xØ6÷35 no cable terminal 9xØ6÷10	2xØ6÷25 + cable terminal 2xØ6÷35 no cable terminal 2xØ6÷16 9xØ6÷10	8xØ2,5÷16 3xØ6÷35	N°22 holes M5 with 17,5mm pitch per phase (threaded busb. 20x5mm)	N°32 holes M5 with 17,5mm pitch per phase (threaded busb. 20x5mm)
Dimensions HxWxD (mm)	45x75x98	89x93x48	126x93x48	90x160x50	150x600x70	150x800x70
N° DIN modules	5,5	5	7	9	24	36
Rated service voltage Ue (V)	500	690	690	500	500	500
Degree of protection IP	20	20	20	20		

⁽¹⁾ possibility of putting in parallel with AD1083 connections.

⁽²⁾ possibility of putting in parallel with comb type connection (not supplied).

Flexible busbars

Cross-section	In (A)	Code	N° busbar/phase	IP31	capacity (A) IP41	IP65	WxW (mm)	Section dimensions (mm²)	Lenght (mm)	Weight (kg)
	250	BF1602	1	395	323	250	20x3	60	2000	1,42
	400	BF2502	1	498	460	400	20x5	100	2000	2,15
	500	BF4002	1	660	620	500	24x6	144	2000	3
	630	BF4012⁽¹⁾	1	758	702	630	32x5	160	2000	3,36

ArTu M monobloc structures

Distribution systems

Busbar holders and crosspieces

Vertical installation

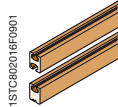
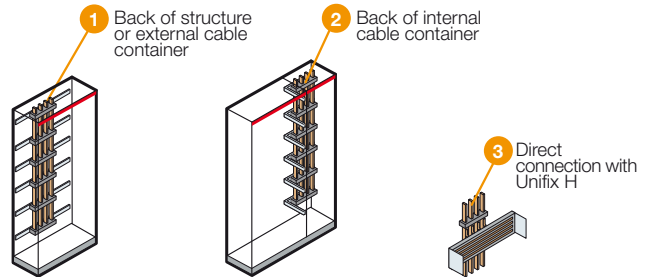

Busbar holder

Busbars with shaped section

Crosspieces for fixing to structure

Type	In ≤ 400÷800A	Installation	Structure 24/36 DIN modules	Internal cable container	Additional cable container
Scaled up to 800A PB0802	BA0400 BA0800	1			TR3001 (W=300mm)
		2		TV2000 (W=200mm)	
Linear up to 800A PB0803	BA0400 BA0800	1	TV6200 (W=600mm) TV8200 (W=800mm)		
		3	TV6200 (W=600mm) TV8200 (W=800mm)		

Busbars with shaped section for applications up to 800A

Cross-section	In (A)	Code	N° busbar/phase	capacity (A)		Icw max (kA)	WxW (mm)	Section dimensions (mm²)	Length (mm)	Weight (kg)
				IP31	IP65					
	400	BA0400	1	630	400	35	20x20	200	1730	4
	800	BA0800	1	970	800	35	20x20	283	1730	4,4

Selection and assembly of busbars with shaped section and busbar holders

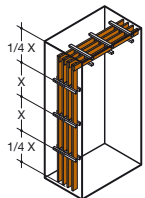

The distance between the first busbar holder and the end of the busbar must not exceed $\frac{1}{4}$ of "X".

max X = maximum distance not to be exceeded between two consecutive busbar holders

N° of busbar holders according to the max. I_{cc}

Busbar code	capacity	Busbar holder code	N° busbars per phase	25 kA		35 kA		50 kA		65 kA		75 kA		85 kA		100 kA	
				X max (mm)	X max (mm)	X max (mm)	X max (mm)	X max (mm)	X max (mm)	X max (mm)	X max (mm)						
Linear																	
BA0400	400A	PB0803	1	4	550	5	425	-	-	-	-	-	-	-	-	-	-
BA0800	800A	PB0803	1	4	550	4	550	-	-	-	-	-	-	-	-	-	-
Scaled																	
BA0400	400A	PB0802	1	4	550	4	550	-	-	-	-	-	-	-	-	-	-
BA0800	800A	PB0802	1	4	550	4	550	-	-	-	-	-	-	-	-	-	-

Using the correct number of busbar holders ensures resistance to electrodynamic forces in the case of a short-circuit. Assess the maximum distance (max X) which must not be exceeded between two consecutive busbar holders according to the max. I_{cc}.

ArTu M monobloc structures

Distribution systems

Busbar holders and crosspieces

Installazione verticale

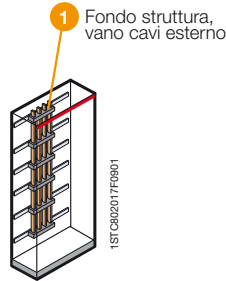

Busbar holder	Busbars with shaped section			Installation	Crosspieces for fixing to structure	
Type	In=250A	In=400A	In=630A		Structure	Additional cable container
Linear up to 630A BP0630 (1)	BR0250	BR0400	BR0630	1	TV6200 (W=600mm) TV8200 (W=800mm)	TR3001 (W=300mm)

(1) The busbar terminal protection covers must be ordered separately **BP0632**.

Flat busbars for distribution up to 630A

Cross-section	In (A)	Code	N° busbar/phase	capacity (A)		Icw max (kA)	WxW (mm)	Lenght (mm)	Weight (kg)
				IP31	IP65				
	250	BR0250	1	290	250	23	15x5	1750	1,35
	400	BR0400	1	475	400	23	25x5	1750	1,8
	630	BR0630	1	750	630	32	30x10	1750	4,4

ArTu M monobloc structures

Distribution systems

Selection and assembly of flat busbars and busbar holders

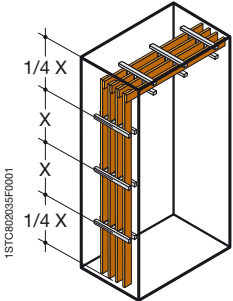

The distance between the first busbar holder and the end of the busbar must not exceed $\frac{1}{4}$ of "X".

N° of busbar holders according to the max. I_{cc}

Busbar code	capacity	Busbar holder code	N° busbars per phase	16 kA		20 kA		23 kA		32 kA	
				X max (mm)	X max (mm)	X max (mm)	X max (mm)	X max (mm)	X max (mm)		
BR0250	250A	BP0630	1	4	500	6	350	10	200	-	-
BR0400	400A		1	4	500	6	350	10	200	-	-
BR0630	630A		1	-	-	4	600	4	600	9	210

max X = maximum distance not to be exceeded between two consecutive busbar holders

Using the correct number of busbar holders ensures resistance to electrodynamic forces in the case of a short-circuit. Assess the maximum distance (max X) which must not be exceeded between two consecutive busbar holders according to the max. I_{cc} .

Flat drilled and threaded busbars for earthing connection

Cross-section	Code	Threading	Pitch	WxW (mm)	Length (mm)	AxB (mm)
	EV1119	6 MA	20	20x5	2000	
	EV1120	6 MA	20	25x5	2000	
	EV1121	6MA	25	50x5	2000	
	EV1122	6MA				34x30
	EV1123	8MA				34x30
	EV1124	6MA				40x50
	EV1125	8MA				40x50

ArTu M monobloc structures

Distribution systems

Technical characteristics

Technical characteristics	Unifix H	Unifix L
Rated service voltage (U_n)	690V AC	400V AC
Rated insulation voltage (U)	1000V AC	500V AC
Rated impulse withstand voltage (U_{imp})	8kV	6kV
Rated frequency	50/60Hz	50/60Hz
Rated current (I_n)	central power supply 400A lateral power supply 320A	100A 80A
Rated short-time withstand current (I_{sw})	25kA	
Maximum peak current (I_{pk})	52,5kA-400V	
Maximum installable circuit-breaker size	250A	100A
Conditioned short-circuit current (I_{cc})	Tmax T1 36kA-400V Tmax T2 N, S ⁽¹⁾ 50kA-400V Tmax T3 50kA-400V Tmax XT1 50kA-400V Tmax XT3 50kA-400V	
With circuit-breaker	S200 S200 M S200 P	6kA-400V 10kA-400V 25kA-400V
Degree of protection	IP20 with accessory	IP20
Characteristics of the insulating material	Self-extinguishing thermoplastic V1 (UL94)	Self-extinguishing thermoplastic V1 (UL94)
Characteristics of the conductor material	Electrolytic copper	Electrolytic copper
Width (No. modules/mm)	24/600 36/800	12/400 24/600 36/800

Installation of Unifix system

Frame for Tmax T and Tmax XT series	300x600mm (hxl) 300x800mm (hxl)	ED2183 ED2191	
Fixing brackets H=300mm		AD1097	
Crosspiece for direct connection to the rear busbars with shaped section with PB0803	W=600mm W=800mm	TL1000 TL1100	
Busbar 2P	12 mod. 18 mod. 24 mod. 36 mod.		ED2993 ED3009 ED3017 ED3025
Busbar 4P	12 mod. 18 mod. 24 mod. 36 mod.		ED2944 ED2951 ED2969 ED2977
Fixing support	24 mod. 36 mod.		GD1520 GD1530

⁽¹⁾ Select circuit-breakers in version with front terminals for copper cables.

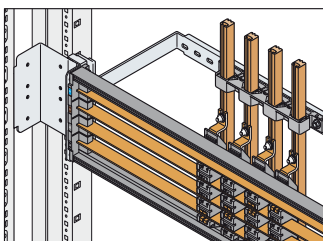

Direct connection with the 400/800A system of busbars with shaped section.

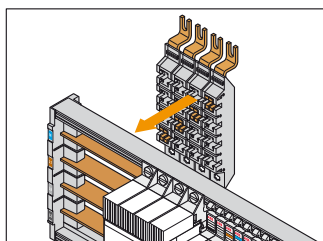

Feeder module for 400A frame (L1-L2-L3-N).

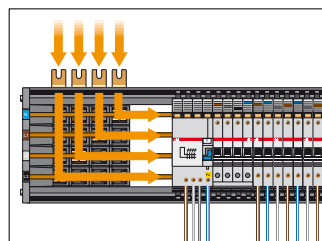

Direct power supply of the bases by means of feeder module ED2209.

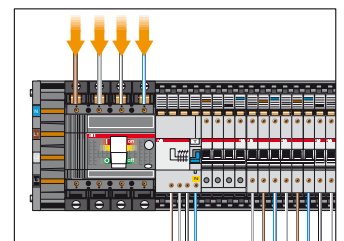

Power supply by means of general row circuit-breaker.

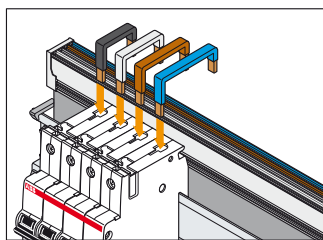

Connections (L1-L2-L3-N) for System Pro M modular apparatus.

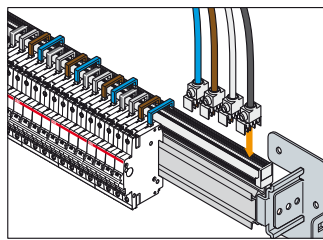

Power supply of the busbar with 100A feeder module without cable. Terminal capacity 35mm².

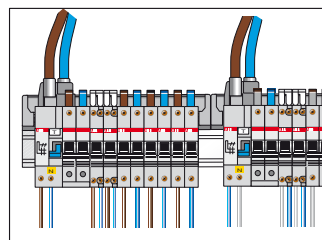

Direct power supply of the busbars by means of feeder module.

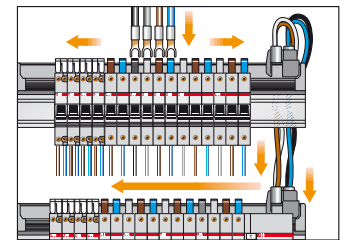

Power supply by means of modules and cables in parallel.

Selection by componentspage 9/12

In-depth technical informationpage 6/10

Overall dimensionspage 8/10

ArTu M monobloc structures

Distribution systems

Table for selecting connections according to the circuit-breaker

Circuit-breaker series	Unifix H	Unifix L
S941 - S951 - S971 DS941 - DS951 - DS971	(top power supply) ED2654 L1/N 40A ED2662 L2/N 40A ED2670 L3/N 40A	ED3272 L1/N 40A ED3280 L2/N 40A ED3298 L3/N 40A
S200 - DS 200 F200 ≤ 63 A (Unifix L)	(top power supply) (bottom power supply) ED2531 L1 63A ED2572 L1 63A ED2549 L2 63A ED2590 L2 63A ED2556 L3 63A ED2598 L3 63A ED2564 N 63A ED2606 N 63A ED2845 False pole module	ED3033 L1 100A ED3041 L2 100A ED3058 L3 100A ED3066 N 100A
S800	(top power supply) ED2557 L1 ≤32A ED2558 L2 ≤32A ED2559 L3 ≤32A ED2560 N ≤32A ED2551 L1 125A ED2552 L2 125A ED2553 L3 125A ED2554 N 125A ED2550 False pole module	
F660 - F670 - S280 (80-100A) E200 up to 100A - RS370 - F200 800-100A (Unifix H)	(bottom power supply) ED2720 L1 100A ED2738 L2 100A ED2746 L3 100A ED2753 N 100A	ED3132 L1/L2/L3/N pow. supply - 350mm ED0026 L1/L2/L3/N pow. supp.- 1500mm ED0025 L1/L2/L3/N pow. supp. - 2500mm
MDRC - Various apparatus	(bottom power supply) (bottom power supply) ED2894 L1/N 16A ED2910 L1/N 16A ED2902 L1/L2 16A ED2928 L1/L2 16A	ED3108 Power supply 2 cab. L1/N 16A ED3116 Pow. supply 3 cab. L1/L2/L3 16A ED3124 Pow. supp. 4 cab. L1/L2/L3/N 16A ED3355 Power supply 2 cab. L1/N 40A ED3363 Pow. supply 3 cab. L1/L2/L3 40A ED3371 Pow. supp. 4 cab. L1/L2/L3/N 71A
Tmax T1 Tmax XT1	Circuit-breaker Residual current Solenoid operator	(top/bottom power supply) ED2217 L1 Top/L2 Bottom ED2225 L2 Top/L1 Bottom ED2233 L3 Top/N Bottom ED2241 N Top/L3 Bottom ED2373 False pole module ED2381 False pole module
Tmax T2	Circuit-breaker Residual current Solenoid operator	(top/bottom power supply) ED2258 L1 Top/L2 Bottom ED2266 L2 Top/L1 Bottom ED2274 L3 Top/N Bottom ED2282 N Top/L3 Bottom ED2373 False pole module ED2399 False pole module
Tmax T3 Tmax XT3	Circuit-breaker Residual current	(top power supply) (bottom power supply) ED2290 L1 ED2332 L1 ED2308 L2 ED2340 L2 ED2316 L3 ED2357 L3 ED2324 N ED2365 N ED2373 False pole module

For the DDA locks, order the false module **ED2845** codes separately according to the size of the residual current lock.

ArTu M monobloc structures

Examples of configurations

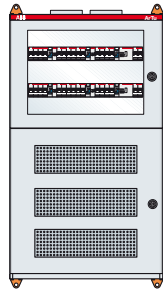

ArTu M Series dim. 1100x600x200 (1130x700x200)mm (external hxwxd) IP65 with modular panels

Code	Description	Q.ty
SM1069	ArTu M structure 1000x600x200mm (hxwxd) QSO + acc.	1

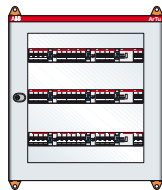

ArTu M Series dim. 600x600x150 (700x700x150) mm (external hxwxd) IP65 with modular panels

Code	Description	Q.ty
SM6061	ArTu M structure 600x600x150mm (hxwxd)	1
PM6672	Panel 72 mod.600x600mm (hxw) M, K	1
GD6002	DIN rail kit not segregated 24 mod. w=600mm, K	3
PV6060	Glass door 600x600mm (hxw) M	1
AA1206	N °4 wall fixing brackets M	1

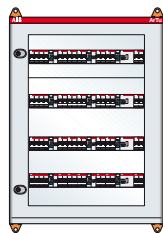

ArTu M Series dim. 800x600x150 (900x700x150) mm (external hxwxd) IP65 with modular panels

Code	Description	Q.ty
SM8061	ArTu M structure 800x600x150mm (hxwxd)	1
PM2624	Panel 24 mod.200x600mm (hxw) M, K	1
PM6672	Panel 72 mod.600x600mm (hxw) M, K	1
GD6002	DIN rail kit not segregated 24 mod. w=600mm, K	4
PV8060	Glass door 800x600mm (hxw) M	1
AA1206	N °4 wall fixing brackets M	1

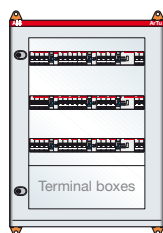

ArTu M Series dim. 800x600x200 (900x700x200) mm (external hxwxd) IP65 with modular panels

Code	Description	Q.ty
SM8062	ArTu M structure 800x600x200mm (hxwxd)	1
PC2600	Panel 24 mod.200x600mm (hxw) M, K	1
PM6672	Panel 72 mod.600x600mm (hxw) M, K	1
GD6002	DIN rail kit not segregated 24 mod. w=600mm, K	3
PV8060	Glass door 800x600mm (hxw) M	1
AA1206	N °4 wall fixing brackets M	1

ArTu M monobloc structures

Examples of configurations

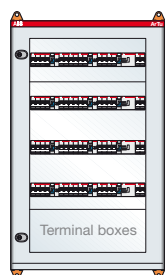

ArTu M Series dim. 1000x600x200 (1000x700x200) mm (external hxwxd) IP65 with modular panels

Code	Description	Q.ty
SM1062	ArTu M structure 1000x600x200mm (hxwxd)	1
PC2600	Blind panel 200x600mm (hwx) M, K	1
PM2624	Panel 24 mod.200x600mm (hwx) M, K	1
PM6672	Panel 72 mod.600x600mm (hwx) M, K	1
GD6002	DIN rail kit not segregated 24 mod. w=600mm, K	4
PV1060	Glass door 1000x600mm (hwx) M	1
AA1206	N °4 wall fixing brackets M	1

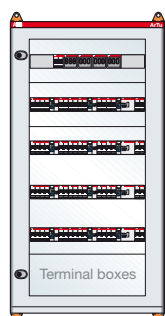

ArTu M Series dim. 1200x600x200 (1300x700x200) mm (external hxwxd) IP65 with modular panels

Code	Description	Q.ty
SM1262	ArTu M structure 1200x600x200mm (hxwxd)	1
PC2600	Blind panel 200x600mm (hwx) M, K	1
PM2624	Panel 24 mod.200x600mm (hwx) M, K	2
PM6672	Panel 72 mod.600x600mm (hwx) M, K	1
GD6002	DIN rail kit not segregated 24 mod. w=600mm, K	5
PV1260	Glass door 1200x600mm (hwx) M	1
AA1206	N °4 wall fixing brackets M	1

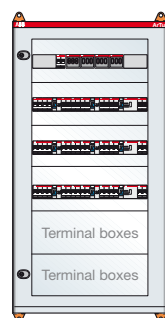

ArTu M Series dim. 1200x600x200 (1300x700x200) mm (external hxwxd) IP65 with modular panels

Code	Description	Q.ty
SM1262	ArTu M structure 1200x600x200mm (hxwxd)	1
PC2600	Blind panel 200x600mm (hwx) M, K	2
PM2624	Panel 24 mod.200x600mm (hwx) M, K	4
GD6002	DIN rail kit not segregated 24 mod. w=600mm, K	4
PV1260	Glass door 1200x600mm (hwx) M	1
AA1206	N °4 wall fixing brackets M	1

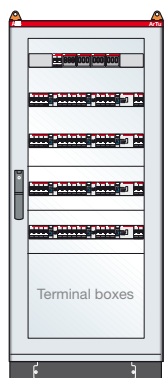

ArTu M Series dim. 1400x600x250 (1596x724x250) mm (external hxwxd) IP65 with modular panels

Code	Description	Q.ty
SM1462	ArTu M structure 1400x600x250mm (hxwxd)	1
PC4600	Blind panel 400x600mm (hwx) M, K	1
PM2624	Panel 24 mod.200x600mm (hwx) M, K	2
PM6672	Panel 72 mod.600x600mm (hwx) M, K	1
GD6002	DIN rail kit not segregated 24 mod. w=600mm, K	5
PV1460	Glass door 1400x600mm (hwx) M	1
LF1425	N° 2 side panels 1400x250mm (hxd) M	1
AA1206	N °4 wall fixing brackets M	1

ArTu M monobloc structures

Examples of configurations

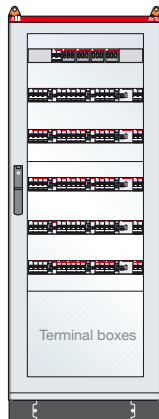

ArTu M Series dim. 1600x600x250 (1796x724x250) mm (external hxwxd) IP65 with modular panels

Code	Description	Q.ty
SM1662	ArTu M structure 1600x600x250mm (hxwxd)	1
PC4600	Blind panel 400x600mm (hxw) M, K	1
PM6672	Panel 72 mod.600x600mm (hxw) M, K	2
GD6002	DIN rail kit not segregated 24 mod. w=600mm, K	6
PV1660	Glass door 1600x600mm (hxw) M	1
LF1625	N° 2 side panels 1600x250mm (hxd) M	1
AA1206	N °4 wall fixing brackets M	1

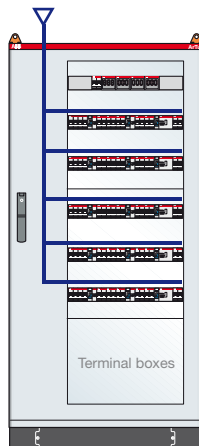

ArTu M Series dim. 1600x800x250 (1796x924x250) mm (external hxwxd) IP65 with modular panels

Code	Description	Q.ty
SM1682	ArTu M structure 1600x800x250mm (hxwxd)	1
PC4600	Blind panel 400x600mm (hxw) M, K	1
PM6672	72 mod. Panel 600x600mm (hxw) M, K	2
GD6002	DIN rail kit not segregated 24 mod. w=600mm, K	6
PV1680	Glass door 1600x800mm (hxl) M	1
VC1622	Internal cable container 1600x200x250mm M	1
LF1625	N°2 side panels 1600x250mm (hxd) M	1
AA1206	N °4 wall fixing brackets M	1

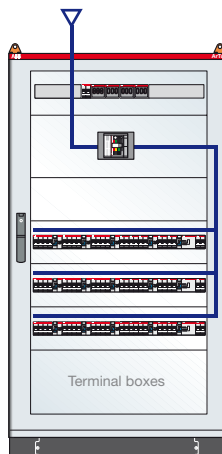

ArTu M Series dim. 1600x800x250 (1796x924x250) mm (external hxwxd) IP65 with plate for Tmax T5 and modular panels

Code	Description	Q.ty
SM1682	ArTu M structure 1600x800x250mm (hxwxd)	1
PC2800	Blind panel 200x800mm (hxw) M, K	1
PC3800	Blind panel 300x800mm (hxw) M, K	1
KL5114	T5 horiz. fixed kit 300x800mm (hxw), M, K	1
PM2836	Panel 36 mod.200x800mm (hxw) M, K	4
GD8002	DIN rail kit not segregated 36 mod. w=800mm, K	4
PV1688	Glass door 36 mod. 1600x800mm (hxw) M	1
LF1625	N° 2 side panels 1600x250mm (hxd) M	1
AA1206	N °4 wall fixing brackets M	1

ArTu M monobloc structures

Examples of configurations

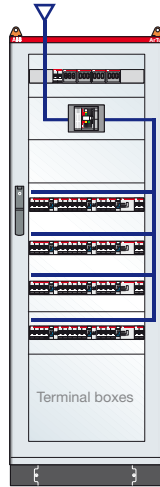

ArTu M Series dim. 1800x600x250 (1996x724x250) mm (external hxwxd) IP65 with plate for Tmax T3 and modular panels, complete with 400A vertical busbars on back of structure - max. Icw 35kA

Code	Description	Q.ty
SM1862	ArTu M structure 1800x600x250mm (hxwxd)	1
KT3112	T3 3/4P horiz. fixed kit not segregated M, K250	1
PC2600	Blind panel 200x600mm (hxw) M, K	1
PC4600	Blind panel 400x600mm (hxw) M, K	1
PM2624	Panel 24 mod.200x600mm (hxw) M, K	2
PM6672	Panel 72 mod.600x600mm (hxw) M, K	1
GD6002	DIN rail kit not segregated 24 mod. w=600mm, K	5
PV1860	Glass door 1800x600mm (hxw) M	1
LF1825	N° 2 side panels 1800x250mm (hxd) M	1
AA1206	N° 4 wall fixing brackets M	1
PB0803	Linear busbar holder In=800A (35kA)	5
BA0400	Busbar In=400A	4
TV6200	N° 2 rear crosspieces w=600mm	3
AD1064	N°12 joining screw M8 W=27mm flat busbars up to10mm	1

ArTu M Series dim. 1800x600x250 (1996x724x250) mm (external hxwxd) IP65 with plate for Tmax XT3 and modular panels, complete with 400A vertical busbars on back of structure - max. Icw 35kA

Code	Description	Q.ty
SM1862	ArTu M structure 1800x600x250mm (hxwxd)	1
KX3612	XT3 3/4P horiz. fixed kit not segregated M, K250	1
PC2600	Blind panel 200x600mm (hxw) M, K	1
PC4600	Blind panel 400x600mm (hxw) M, K	1
PM2624	Panel 24 mod.200x600mm (hxw) M, K	2
PM6672	Panel 72 mod.600x600mm (hxw) M, K	1
GD6002	DIN rail kit not segregated 24 mod. w=600mm, K	5
PV1860	Glass door 1800x600mm (hxw) M	1
LF1825	N° 2 side panels 1800x250mm (hxd) M	1
AA1206	N° 4 wall fixing brackets M	1
PB0803	Linear busbar holder In=800A (35kA)	5
BA0400	Busbar In=400A	4
TV6200	N° 2 rear crosspieces w=600mm	3
AD1064	N°12 joining screw M8 W=27mm flat busbars up to10mm	1

ArTu M monobloc structures

Examples of configurations

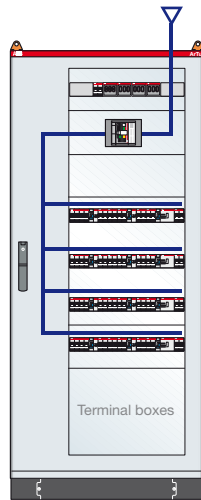

ArTu M Series dim. 1800x800x250 (1996x924x250) mm (external hwxwd) IP65 with plate for Tmax T3 and modular panels, complete with 800A vertical busbars on back of internal cable container - max. I_{cw} 35kA

Code	Description	Q.ty
SM1882	ArTu M structure 1800x800x250mm (hwxwd)	1
KT3112	T3 3/4P horiz. fixed kit not segregated M, K250	1
PC2600	Blind panel 200x600mm (hwx) M, K	1
PC4600	Blind panel 400x600mm (hwx) M, K	1
PM2624	Panel 24 mod.200x600mm (hwx) M, K	2
PM6672	Panel 72 mod.600x600mm (hwx) M, K	1
GD6002	DIN rail kit not segregated 24 mod. w=600mm, K	5
PV1880	Glass door 1800x800mm (hwx) M	1
LF1825	N° 2 side panels 1800x250mm (hxd) M	1
VC1822	Int. cable container 1800x200x250mm M	1
AA1206	N° 4 wall fixing brackets M	1
PB0802	Scaled busbar holder In=800A (35kA)	5
BA0800	Busbar In=800A	4
TV2000	N° 2 rear crosspieces w=200mm	3
AD1064	N°12 joining screw M8 W=27mm flat busbars up to10mm	1

ArTu M Series dim. 1800x800x250 (1996x924x250) mm (external hwxwd) IP65 with plate for Tmax XT3 and modular panels, complete with 800A vertical busbars on back of internal cable container - max. I_{cw} 35kA

Code	Description	Q.ty
SM1882	ArTu M structure 1800x800x250mm (hwxwd)	1
KX3612	XT3 3/4P horiz. fixed kit not segregated M, K250	1
PC2600	Blind panel 200x600mm (hwx) M, K	1
PC4600	Blind panel 400x600mm (hwx) M, K	1
PM2624	Panel 24 mod.200x600mm (hwx) M, K	2
PM6672	Panel 72 mod.600x600mm (hwx) M, K	1
GD6002	DIN rail kit not segregated 24 mod. w=600mm, K	5
PV1880	Glass door 1800x800mm (hwx) M	1
LF1825	N° 2 side panels 1800x250mm (hxd) M	1
VC1822	Int. cable container 1800x200x250mm M	1
AA1206	N° 4 wall fixing brackets M	1
PB0802	Scaled busbar holder In=800A (35kA)	5
BA0800	Busbar In=800A	4
TV2000	N° 2 rear crosspieces w=200mm	3
AD1064	N°12 joining screw M8 W=27mm flat busbars up to10mm	1

4

ArTu M monobloc structures

Examples of configurations

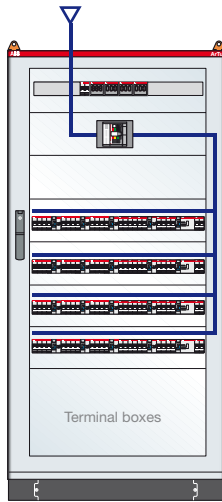

ArTu M Series dim. 1800x800x250 (1996x924x250) mm (external hxwxd) IP65 with plate for Tmax T3 and modular panels, complete with 800A vertical busbars on back of structure - max. Icw 35kA

Code	Description	Q.ty
SM1882	ArTu M structure 1800x800x250mm (hxwxd)	1
PC2800	Blind panel 200x800mm (hxw) M, K	1
PC4800	Blind panel 400x800mm (hxw) M, K	1
KL3113	T3 3/4P horiz. fixed kit not segregated M, K250	1
PM2836	Panel 36 mod.200x800mm (hxw) M, K	5
GD8002	DIN rail kit not segregated 36 mod. w=800mm, K	5
PV1888	Glass door 36 mod. 1800x800mm (hxw) M	1
LF1825	N° 2 side panels 1800x250mm (hxd) M	1
AA1206	N° 4 wall fixing brackets M	1
PB0803	Linear busbar holder In=800A (35kA)	5
BA0800	Busbar In=800A	4
TV8200	N° 2 rear crosspieces w=800mm	3
AD1064	N°12 joining screw M8 W=27mm flat busbars up to10mm	1

ArTu M Series dim. 1800x800x250 (1996x924x250) mm (external hxwxd) IP65 with plate for Tmax XT3 and modular panels, complete with 800A vertical busbars on back of structure - max. Icw 35kA

Code	Description	Q.ty
SM1882	ArTu M structure 1800x800x250mm (hxwxd)	1
PC2800	Blind panel 200x800mm (hxw) M, K	1
PC4800	Blind panel 400x800mm (hxw) M, K	1
KL3613	XT3 3/4P horiz. fixed kit not segregated M, K250	1
PM2836	Panel 36 mod.200x800mm (hxw) M, K	5
GD8002	DIN rail kit not segregated 36 mod. w=800mm, K	5
PV1888	Glass door 36 mod. 1800x800mm (hxw) M	1
LF1825	N° 2 side panels 1800x250mm (hxd) M	1
AA1206	N° 4 wall fixing brackets M	1
PB0803	Linear busbar holder In=800A (35kA)	5
BA0800	Busbar In=800A	4
TV8200	N° 2 rear crosspieces w=800mm	3
AD1064	N°12 joining screw M8 W=27mm flat busbars up to10mm	1

ArTu M monobloc structures

Examples of configurations

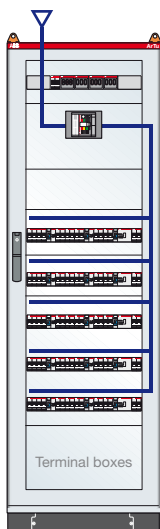

ArTu M Series dim. 2000x600x250 (2196x724x250) mm (external hxwxd) IP65 with plate for Tmax T5 and modular panels, complete with 400A vertical busbars on back of structure - max. Icw 35kA

Code	Description	Q.ty
SM2062	ArTu M structure 2000x600x250mm (hxwxd)	1
KT5112	T5 horiz. fixed kit 300x600mm (hxw) M, K	1
PC2600	Blind panel 200x600mm (hxw) M, K	1
PC3600	Blind panel 300x600mm (hxw) M, K	1
PM2624	Panel 24 mod.200x600mm (hxw) M, K	3
PM6672	Panel 72 mod.600x600mm (hxw) M, K	1
GD6002	DIN rail kit not segregated 24 mod. w=600mm, K	6
PV2060	Glass door 2000x600mm (hxw) M	1
LF2025	N° 2 side panels 2000x250mm (hxd) M	1
AA1206	N° 4 wall fixing brackets M	1
PB0803	Linear busbar holder In=800A (35kA)	5
BA0800	Busbar In=800A	4
TV6200	N° 2 rear crosspieces w=600mm	3
AD1064	N°12 joining screw M8 W=27mm flat busbars up to10mm	1

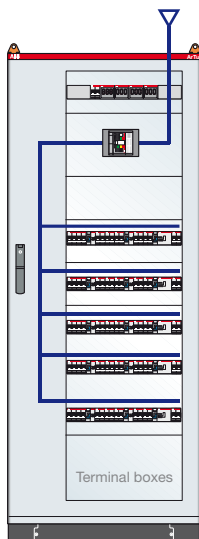

ArTu M Series dim. 2000x800x250 (2196x924x250) mm (external hxwxd) IP65 with plate for Tmax T5 and modular panels, complete with 800A vertical busbars on back of internal cable container - max. Icw 35kA

Code	Description	Q.ty
SM2082	ArTu M structure 2000x800x250mm (hxwxd)	1
KT5112	T5 horiz. fixed kit 300x800mm (hxw) M, K	1
PC2600	Blind panel 200x600mm (hxw) M, K	1
PC3600	Blind panel 300x600mm (hxw) M, K	1
PM2624	Panel 24 mod.200x600mm (hxw) M, K	3
PM6672	Panel 72 mod.600x600mm (hxw) M, K	1
GD6002	DIN rail kit not segregated 24 mod. w=600mm, K	6
PV2080	Glass door 2000x800mm (hxw) M	1
LF2025	N° 2 side panels 2000x250mm (hxd) M	1
VC2022	Int. cable container 2000x200x250mm M	1
AA1206	N° 4 wall fixing brackets M	1
PB0802	Scaled busbar holder In=800A (35kA)	5
BA0800	Busbar In=800A	4
TV2000	N° 2 rear crosspieces w=200mm	3
AD1064	N°12 joining screw M8 W=27mm flat busbars up to10mm	1

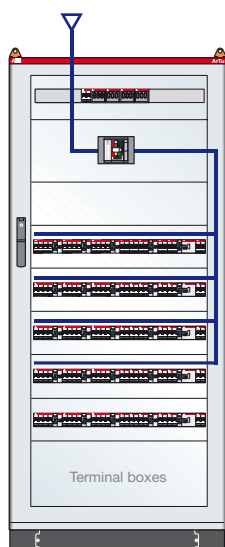

ArTu M Series dim. 2000x800x250 (2196x924x250)mm (external hxwxd) IP65 with plate for Tmax T5 and modular panels, complete with 800A vertical busbars on back of structure- max. Icw 35kA

Code	Description	Q.ty
SM2082	ArTu M structure 2000x800x250mm (hxwxd)	1
PC2800	Blind panel 200x800mm (hxw) M, K	1
PC3800	Blind panel 300x800mm (hxw) M, K	1
KL5114	T5 horiz. fixed kit 300x800mm (hxw) M, K	1
PM2836	Panel 36 mod.200x800mm (hxw) M, K	6
GD8002	DIN rail kit not segregated 36 mod. w=800mm, K	6
PV2088	Glass door 36 mod. 2000x800mm (hxw) M	1
LF2025	N° 2 side panels 2000x250mm (hxd) M	1
AA1206	N° 4 wall fixing brackets M	1
PB0803	Linear busbar holder In=800A (35kA)	5
BA0800	Busbar In=800A	4
TV8200	N° 2 rear crosspieces w=800mm	3
AD1064	N°12 joining screw M8 W=27mm flat busbars up to10mm	1



Index

General	5/2
Selection of the structure	5/4
Kit for installing apparatus.....	5/12
Distribution systems.....	5/30
Examples of configurations.....	5/38

ArTu K Modular Structures

General

The K series of ArTu switchgear consists of a series of components for configuration of floor-standing kit switchgear, with the following dimensions:

- three heights (useful)
- 1600 mm (16 modules of 100 mm), 1800 mm (18 modules of 100 mm) and 2000 mm (20 modules of 100 mm) to which the h=100mm base strip measurement fitted with removable flanges must always be added;
- three widths (useful)
- 390mm (12 DIN modules), 600 mm (24 DIN modules) and 800 mm (36 or 24 DIN modules + cable riser);
- five depths (useful)
150 mm (for Tmax T6 up to fixed 630A S6) 225mm (for Tmax up to fixed 800A S6), 300mm (for Tmax T7 1600A), 500 mm (for Tmax to fixed T71600A), 700mm (for Emax up to withdrawable E3 3200A) and 900mm (for Emax up to withdrawable E4 4000A).

Tmax XT series can be installed in each one of the above-mentioned depths.

The structure is made entirely of hot galvanised steel sheet, which guarantees the equipotentiality of the switchgear.



1STC062258F 0001



1STC062258F 0001

Base and top are supplied pre-mounted by means of a three-way joint, which is able to provide considerable structural rigidity. The base is fitted with removable flanges which allow entry into the areas reserved for the cables and a pre-mounted (H=100mm) base strip, consisting of four angle irons with removable over the whole perimeter.

The four uprights are fitted with a multi-purpose hinge used to assemble the door and to couple the structures, both laterally and at the rear.

The structure is completed with two types of functional frames, fitted with reference nicks (at 100 mm pitch) to avoid annoying nicks during assembly of the apparatus kits:

- open functional frame (can be used in switchgear where no form of segregation is required);
- closed functional frame (can be used in switchgear where forms 2-3 and 4 segregation are required).

Technical characteristics

Compliance with Standards	CEI EN 60439-1/IEC 61439-1-2
Rated insulation voltage Ui	up to 1000 V
Rated frequency	50-60 Hz
Rated impulse withstand voltage Uimp	8 kV
Rated current In	up to 4000 A
Rated short-time short-circuit withstand current Icw	up to 105 kA
Rated peak short-circuit current Ipk	up to 254 kA
Degree of protection IP	31 without door
	41 with accessories
	65 with door and blind panel

ArTu K Modular Structures

General

The switchgear is completed with:

- blind (IP65) and ventilated (IP41) type side panels;
- blind and transparent doors, fitted with safety glass which can be mounted on all sides (IP65).
- kit for installing the apparatus, designed to integrate enclosure structures and circuit-breaker perfectly .

The mounting positions are established previously so as to guarantee the insulation distances and perfect alignment of the apparatus on the front panel. Furthermore, the kit plates are of the self-centring type and are fitted with threaded bushings to provide easy assembly of the apparatus from the front.

- DIN rail kit consisting of a drawn piece of aluminium able to resist the load of the circuit-breakers fitted with fixing brackets (patented), preset to house the vertical and horizontal cabling duct.



The aluminium DIN rail has three established mounting positions, corresponding respectively to the, T and XT series depths of the System Pro M, Tmax and Isomax circuit-breakers. It is fitted with double DIN 35 section (front and rear), and the rear part can be used to support the duct, up to 60x80mm;

- kit for air circuit-breakers consisting of sturdy supporting crosspieces and of the front panel;
- universal kits, consisting of back plates and blind front panels, which allow assembly of generic apparatus.

The panels have vertical 100mm modularity and are fitted with an invisible hinge on the outside, which can be mounted either on the right or on the left, and which guarantees panel earthing, making the equipotential connection superfluous. The DIN panels are also available in the versions for one, two or three rows, corresponding to heights of 200, 300 and 600mm respectively and can have 150/200mm centre distance between the rows.

In the case of modular and moulded-case circuit-breakers placed side by side in the same row, the special section must be used which allows the assembly position of the circuit-breakers to be adapted correctly so that the same modular panel can be used. When the circuit-breakers do not take up the whole window of the panel, the spaces can be closed using the hole covers.

Within the K series of ArTu switchgear with 500, 700 and 900mm depths, segregation compartments of Form 2, 3 and 4 can be made in conformity with the IEC 60439-1 Standard, for the whole range of moulded-case circuit-breakers with rear terminals, simply by using the closed functional frame, the installation kits in the segregated version and the special segregations.

The distribution systems, which can be used inside the ArTu switchgear, consist of:

- shaped section busbars up to 3200A;
- flat busbars up to 4000A;
- flexible busbars;
- Unifix cabling system, structured up to 400A;
- dividers up to 400A.

The extremely compact dimensions of the system allow the busbars to be mounted directly inside the switchgear, positioning them horizontally or vertically, on the back or on the side of the structure, keeping front access, also thanks to the practicality of the scaled type busbar holder.

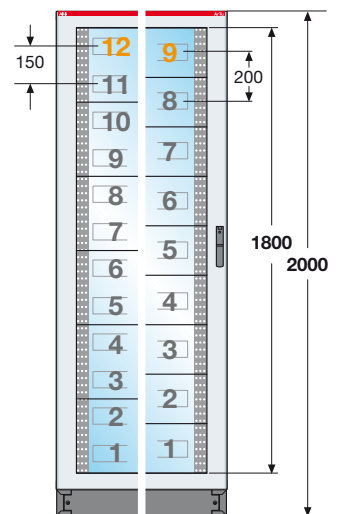

ArTu K Modular Structures

Selection of the structure

Structure

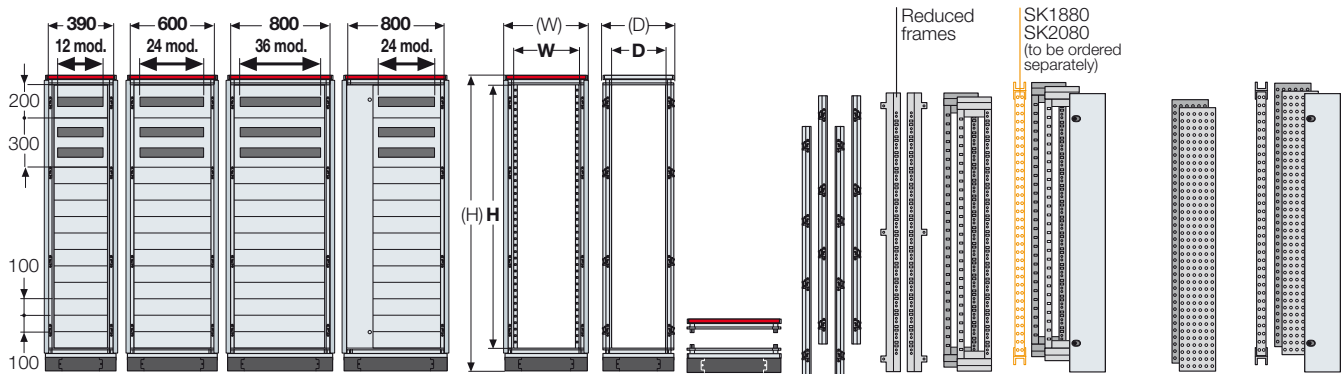

N° vert. mod. H=100mm	N°DIN modules installable		External overall dimensions ⁽¹⁾			Functional dimensions ⁽²⁾			(*)Base Top Base strip	Side flanges base strip	Uprights	Functional frames for switchgear without segregation		Functional frames for segregated switchgear			
	DIN panel 150 mm centre dist.	DIN panel 200 mm centre dist.	(H) mm	(W) mm	(D) ⁽³⁾ mm	H mm	W mm	D ⁽³⁾ mm				Solution 1	Solution 2 ⁽⁴⁾	Solution 1	Solution 2 ⁽⁴⁾		
16	240 (24x10)	192 (24x8)	1831	748	287	1600	600	150	SK6025	ZD1015	SK1600	SK1604 ⁽⁵⁾	-	-	-		
				948	287		800	SK8025	ZD1015	SK1604 ⁽⁵⁾		VC1624 ⁽⁵⁾	-	-			
	360 (36x10)	236 (36x8)	538	362	390	225	SK4040	ZD1025	SK1804 ⁽⁶⁾	-		-	-				
			538	437	390	300	SK4050	ZD1030	SK1804 ⁽⁶⁾	-		-	-				
	144 (12x12)	108 (12x9)	538	637	390	500	SK4060	ZD1050	SK1803	-		SK1802	-				
			538	837	390	700	SK4080	ZD1070	SK1803	-		SK1802	-				
			538	1037	390	900	SK4010	ZD1090	SK1803	-		SK1802	-				
			748	287	600	150	SK6025	ZD1015	SK1804 ⁽⁵⁾	-		-	-				
			748	362	600	225	SK6040	ZD1025	SK1804 ⁽⁶⁾	-		-	-				
			748	437	600	300	SK6050	ZD1030	SK1804 ⁽⁶⁾	-		-	-				
	18	288 (24x12)	216 (24x9)	2031	748	637	1800	600	500	SK6060		ZD1050	SK1800	SK1803	-	SK1802	-
					748	837		600	700	SK6080		ZD1070		SK1803	-	SK1802	-
748					1037	600		900	SK6010	ZD1090	SK1803	-		SK1802	-		
948					287	800		150	SK8025	ZD1015	SK1804 ⁽⁵⁾	VC1824 ⁽⁵⁾		-	-		
948					362	800		225	SK8040	ZD1025	SK1804 ⁽⁶⁾	VC1824 ⁽⁶⁾		-	-		
948					437	800		300	SK8050	ZD1030	SK1804 ⁽⁶⁾	VC1824 ⁽⁶⁾		-	-		
432 (36x12)		324 (36x9)	948	637	800	500	SK8060	ZD1050	SK1803	VC1823	SK1802	VC1820					
			948	837	800	700	SK8080	ZD1070	SK1803	VC1823	SK1802	VC1820					
			948	1037	800	900	SK8010	ZD1090	SK1803	VC1823	SK1802	VC1820					
			538	362	390	225	SK4040	ZD1025	SK2004 ⁽⁵⁾	-	-	-					
			538	437	390	300	SK4050	ZD1030	SK2004 ⁽⁶⁾	-	-	-					
			538	637	390	500	SK4060	ZD1050	SK2003	-	SK2002	-					
20	312 (24x13)	240 (24x10)	2231	538	837	2000	390	700	SK4080	ZD1070	SK2000	SK2003	-	SK2002	-		
				538	1037		390	900	SK4010	ZD1090		SK2003	-	SK2002	-		
				748	287		600	150	SK6025	ZD1015		SK2003	-	SK2002	-		
				748	362		600	225	SK6040	ZD1025		SK2004 ⁽⁵⁾	VC2024 ⁽⁵⁾	-	-		
				748	437		600	300	SK6050	ZD1030		SK2004 ⁽⁶⁾	VC2024 ⁽⁶⁾	-	-		
				948	637		800	500	SK6060	ZD1050		SK2003	-	SK2002	-		
	468 (36x13)	360 (36x10)	948	837	800	700	SK6080	ZD1070	SK2003	VC2023		SK2002	VC2020				
			948	1037	800	900	SK6010	ZD1090	SK2003	VC2023		SK2002	VC2020				
			948	287	800	150	SK8025	ZD1015	SK2004 ⁽⁵⁾	VC2024 ⁽⁵⁾		-	-				
			948	362	800	225	SK8040	ZD1025	SK2004 ⁽⁶⁾	VC2024 ⁽⁶⁾		-	-				
			948	437	800	300	SK8050	ZD1030	SK2004 ⁽⁶⁾	VC2024 ⁽⁶⁾		-	-				
			948	637	800	500	SK8060	ZD1050	SK2003	VC2023		SK2002	VC2020				

⁽¹⁾ The side flanges of the base strip should be ordered separately.

The positioning of two structures or a structure and a cable container side-by-side is realized by the AD1014 kit.

When selecting the components, the characteristics of the apparatus to be mounted inside the switchgear must be taken into consideration, opting for the open frame and cable container when no form of segregation is required and, on the contrary, for the closed frame and cable container when forms of segregation from 2 to 4 are required. According to the type of covering selected, the degree of protection varies from IP31/41 (switchgear without front door) to IP65 (switchgear with front door and blind side panels).

ArTu K Modular Structures

Selection of the structure

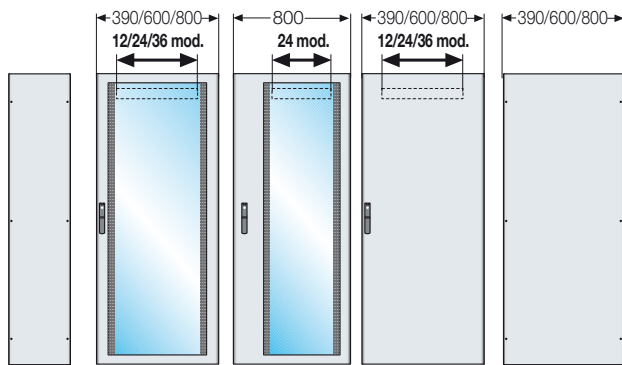

- The overall external dimensions of the ArTu K switchgear include the base strip h=100mm and the side panels, each 14mm wide.
- The functional dimensions represent the useful space for installing the apparatus.
- In this catalogue, reference is always made to the following depths:
functional
 150/225/300/500/700/900 mm
external
 287/362/437/637/837/1037 mm.
- The VC.... code is already complete with the functional frame, therefore it is not necessary to order other open or closed functional frames. Furthermore, the internal cable container is only built with 800mm wide structures. The rear intermediate upright SK 1880 (H=1800mm) or SK 2080 (H=2000mm) in switchgear without segregation must be ordered separately if necessary for fixing onto the back of crosspieces, accessories, busbars, etc.
- Reduced functional frame, only for fixed Tmax T and XT series breakers ≤T6
- With the reduced functional frame for fixed Tmax T and XT series circuit-breakers ≤ T6 or with standard functional frame for all the circuit-breakers.

Side coverings, front and rear coverings IP65

Side panel	Glass door 12/24/36 mod.	Glass door 24 mod. + int. cable cont.	Blind door 12/24/36 mod.	Rear panel
LF1626	PV1661	-	PO1661	RF1660
LF1626	PV1682	PV1681	PO1681	RF1680
LF1840	PV1841	-	PO1841	RF1840
LF1850	PV1841	-	PO1841	RF1840
LF1860	PV1841	-	PO1841	RF1840
LF1880	PV1841	-	PO1841	RF1840
LF1810	PV1841	-	PO1841	RF1840
LF1826	PV1861	-	PO1861	RF1860
LF1840	PV1861	-	PO1861	RF1860
LF1850	PV1861	-	PO1861	RF1860
LF1860	PV1861	-	PO1861	RF1860
LF1880	PV1861	-	PO1861	RF1860
LF1810	PV1861	-	PO1861	RF1860
LF1826	PV1882	PV1881	PO1881	RF1880
LF1840	PV1882	PV1881	PO1881	RF1880
LF1850	PV1882	PV1881	PO1881	RF1880
LF1860	PV1882	PV1881	PO1881	RF1880
LF1880	PV1882	PV1881	PO1881	RF1880
LF1810	PV1882	PV1881	PO1881	RF1880
LF2040	PV2041	-	PO2041	RF2040
LF2050	PV2041	-	PO2041	RF2040
LF2060	PV2041	-	PO2041	RF2040
LF2080	PV2041	-	PO2041	RF2040
LF2010	PV2041	-	PO2041	RF2040
LF2026	PV2061	-	PO2061	RF2060
LF2040	PV2061	-	PO2061	RF2060
LF2050	PV2061	-	PO2061	RF2060
LF2060	PV2061	-	PO2061	RF2060
LF2080	PV2061	-	PO2061	RF2060
LF2010	PV2061	-	PO2061	RF2060
LF2026	PV2082	PV2081	PO2081	RF2080
LF2040	PV2082	PV2081	PO2081	RF2080
LF2050	PV2082	PV2081	PO2081	RF2080
LF2060	PV2082	PV2081	PO2081	RF2080
LF2080	PV2082	PV2081	PO2081	RF2080
LF2010	PV2082	PV2081	PO2081	RF2080

To complete the structure

Switchgears without segregation

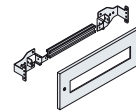

DIN rail and panels Page 5/12

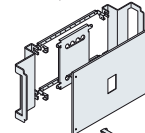

Tmax kits for ArTu
D=150-225-300mm Page 5/13

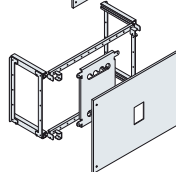

Tmax/Emax kits for ArTu D ≥ 225mm Page 5/14

Segregated switchgears

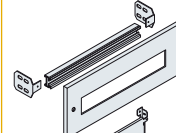

DIN rail and panels Page 5/20

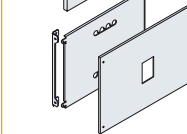

Tmax/Emax kits Page 5/21

Distribution System

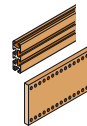

Busbars with shaped section Page 5/32

Flat busbars Page 5/34

IP31/IP41 finishing section Page 9/54

The functional frames of ArTu K switchgear are available in two versions:

- **switchgear without segregation** (open frame) in cases where no form of segregation is required;
- **segregated switchgear** (closed frame) in cases where forms 2-3 and 4 segregation are required

ArTu K Modular Structures

Selection of the structure

Additional cable container

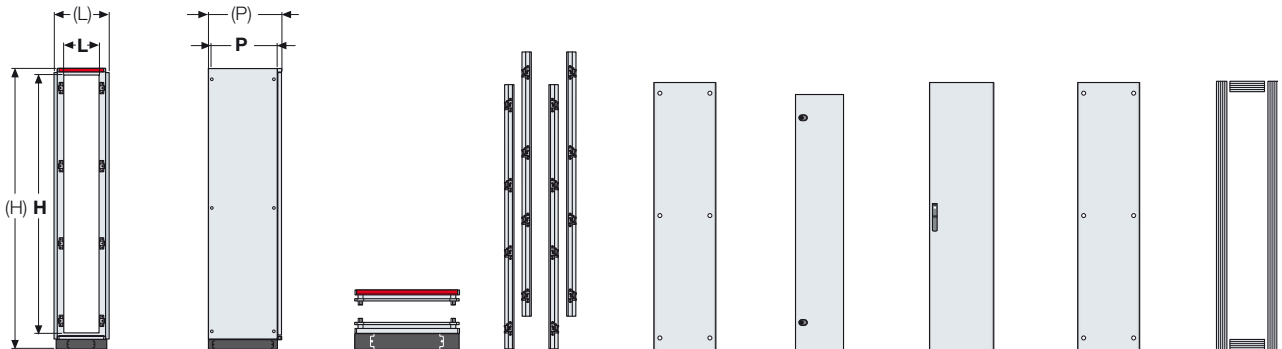

1ST CAD2019F0001

Overall external dimensions ⁽¹⁾			Functional dimensions ⁽²⁾			(*) Base Top Base strip	Side flanges for base strip	Uprights	Side covers, front and rear covers				Finishing section IP31/41
(H)	(W)	(D) ⁽³⁾	H	W	D ⁽³⁾				Blind side door IP65	Internal front door IP31	External front door IP65	Rear panel IP65	
mm	mm	mm	mm	mm	mm								
1831	448	287	1600	300	150	VC3025	ZD1015	SK1600	LF1626	PO1631	PO1633	RF1630	
		287			150	VC3025	ZD1015		LF1826				
		362			225	VC3040	ZD1025		LF1840				
		437			300	VC3050	ZD1030		LF1850				
2031	448	637	1800	300	500	VC3060	ZD1050	SK1800	LF1860	PO1831	PO1833	RF1830	See page 9/54
		837			700	VC3080	ZD1070		LF1880				
		1037			900	VC3010	ZD1090		LF1810				
		287			150	VC3025	ZD1015		LF2026				
		362			225	VC3040	ZD1025		LF2040				
		437			300	VC3050	ZD1030		LF2050				
2231	448	637	2000	300	500	VC3060	ZD1050	SK2000	LF2060	PO2031	PO2033	RF2030	
		837			700	VC3080	ZD1070		LF2080				
		1037			900	VC3010	ZD1090		LF2010				

(*) The side flanges of the base strip should be ordered separately.

(1) The overall external dimensions of the ArTu K switchgear include the base strip h=100mm and the side panels, each 14mm wide.

(2) The functional dimensions represent the useful space for installing the apparatus.

(3) In this catalogue, reference is always made to depths 250/350/600/800/1000mm corresponding to overall external dimensions 287/362/637/837/1037 mm and to useful dimensions 150/225/500/700/900 mm.

Additional structure 300mm wide are available, which can be used as cable containers placed side by side laterally with all the ArTu K switchgear.

In the same way as the structures, the additional cable container is made up of a base, top, base strip and uprights and is fixed to the structures using the side-by-side kits (AD1014). It is completed with the side panels and the doors (to be ordered separately). The external doors are used on the additional cable container to be placed side by side with an ArTu structure with door (IP65); the internal doors are used on the additional cable container placed side by side with an ArTu IP31 version structure (i.e. without door and with finishing sections).

This ensures uniformity of appearance between the structure and additional cable container. Furthermore, the internal doors can be used as internal segregations of the cable container: should a segregation with door open of the additional cable container be requested, it is possible to mount both the internal and external door at the same time.

ArTu K Modular Structures

Selection of the structure

Angle square

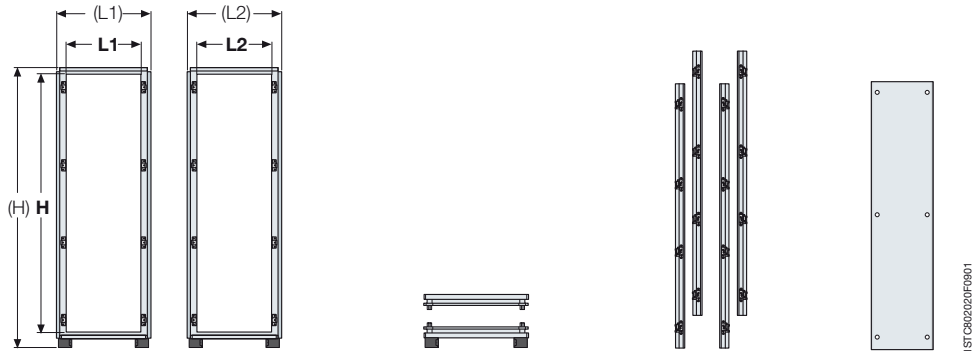

(1) The overall external dimensions of the ArTu K switchgear include the base strip h=100mm.

(2) The functional dimensions represent the useful space for installing the apparatus.

(3) In this catalogue reference is always made to the following depth:
functional 500/700mm
external 637/837mm.

Overall external dimensions ⁽¹⁾			Functional dimensions ⁽²⁾			Base/Top/ Base strip	Uprights	Side covers
(H)	(W1)	(W2) ⁽³⁾	H	W1	W2 ⁽³⁾			Blind side panel IP65
mm	mm	mm	mm	mm	mm			
2031	637	637	1800	500	500	SK6600	SK1815	LF1860
	837	837		700	700	SK8800		LF1880
2231	637	637	2000	500	500	SK6600	SK2015	LF2060
	837	837		700	700	SK8800		LF2080

Example of use

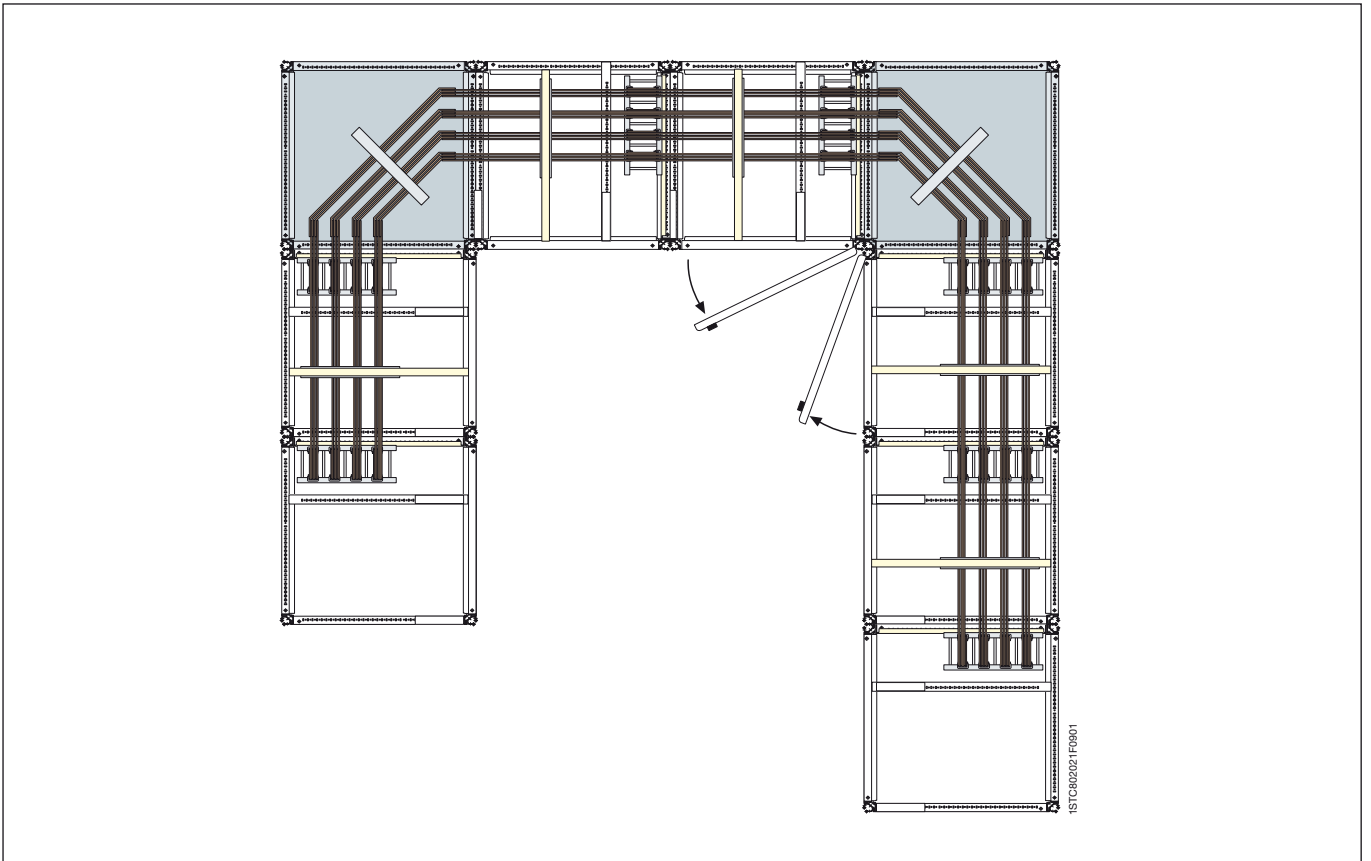

ArTu K Modular Structures

Selection of the structure

Solutions recommended for installation of the apparatus

Apparatus			Type of structure/installation															
			Switchgear without segregation										Segregated switchgear					
			D=150mm		D=225mm		D=300mm		D=500mm		D=700mm		D=900mm		D=500mm		D=700mm	
			Horiz.	Vertic.	Horiz.	Vertic.	Horiz.	Vertic.	Horiz.	Vertic.	Horiz.	Vertic.	Horiz.	Vertic.	Horiz.	Vertic.	Horiz.	Vertic.
System Pro M modular apparatus				•		•		•		•		•		•		•		•
Tmax T1	front terminals	fixed	•	•	•	•	•	•	•	•	•	•	•	•	•	•	•	•
		fixed+diff. mod.	•	•	•	•	•	•	•	•	•	•	•	•	•	•	•	•
	rear terminals	fixed			•	•	•	•	•	•	•	•	•	•	•	•	•	•
Tmax T2	front terminals	fixed	•	•	•	•	•	•	•	•	•	•	•	•	•	•	•	•
		plug-in			•	•	•	•	•	•	•	•	•	•	•	•	•	•
		fixed+diff. mod.	•	•	•	•	•	•	•	•	•	•	•	•	•	•	•	•
	rear terminals	fixed			•	•	•	•	•	•	•	•	•	•	•	•	•	•
	plug-in			•	•	•	•	•	•	•	•	•	•	•	•	•	•	
Tmax T3	front terminals	fixed	•	•	•	•	•	•	•	•	•	•	•	•	•	•	•	•
		plug-in			•	•	•	•	•	•	•	•	•	•	•	•	•	•
		fixed+diff. mod.	•	•	•	•	•	•	•	•	•	•	•	•	•	•	•	•
	rear terminals	fixed					•	•	•	•	•	•	•	•	•	•	•	•
	plug-in					•	•	•	•	•	•	•	•	•	•	•	•	
	fixed+diff. mod.					•	•	•	•	•	•	•	•	•	•	•	•	
Tmax T4	front terminals	fixed	•	•	•	•	•	•	•	•	•	•	•	•	•	•	•	•
		plug-in			•	•	•	•	•	•	•	•	•	•	•	•	•	•
		withdrawable			•	•	•	•	•	•	•	•	•	•	•	•	•	•
		fixed+diff. mod.	•	•	•	•	•	•	•	•	•	•	•	•	•	•	•	•
	rear terminals	fixed					•	•	•	•	•	•	•	•	•	•	•	•
	plug-in					•	•	•	•	•	•	•	•	•	•	•	•	
	withdrawable					•	•	•	•	•	•	•	•	•	•	•	•	
	fixed+diff. mod.					•	•	•	•	•	•	•	•	•	•	•	•	
Tmax T5	front terminals	fixed	•	•	•	•	•	•	•	•	•	•	•	•	•	•	•	•
		plug-in			•	•	•	•	•	•	•	•	•	•	•	•	•	•
		withdrawable			•	•	•	•	•	•	•	•	•	•	•	•	•	•
	rear terminals	fixed					•	•	•	•	•	•	•	•	•	•	•	•
	plug-in					•	•	•	•	•	•	•	•	•	•	•	•	
	withdrawable					•	•	•	•	•	•	•	•	•	•	•	•	
Tmax T6	front terminals	fixed	•	•	•	•	•	•	•	•	•	•	•	•	•	•	•	•
		plug-in					•	•	•	•	•	•	•	•	•	•	•	•
	rear terminals	fixed					•	•	•	•	•	•	•	•	•	•	•	•
	withdrawable					•	•	•	•	•	•	•	•	•	•	•	•	
Tmax T7	front terminals	fixed					•	•	•	•	•	•	•	•	•	•	•	•
		withdrawable					•	•	•	•	•	•	•	•	•	•	•	•
	rear terminals	fixed					•	•	•	•	•	•	•	•	•	•	•	•
	withdrawable					•	•	•	•	•	•	•	•	•	•	•	•	•
Tmax T8	front terminals	fixed							•	•	•	•	•	•	•	•	•	•
	rear terminals	fixed							•	•	•	•	•	•	•	•	•	•
Emax X1	front terminals	fixed							•	•	•	•	•	•	•	•	•	•
		withdrawable							•	•	•	•	•	•	•	•	•	•
Emax E1-E2-E3	rear terminals	fixed									•	•	•	•	•	•	•	•
		withdrawable									•	•	•	•	•	•	•	•
Emax E4	rear terminals	fixed											•	•	•	•	•	•
		withdrawable											•	•	•	•	•	•

ArTu K Modular Structures

Selection of the structure

Solutions recommended for installation of the apparatus

Apparatus			Type of structure/installation																	
			Switchgear without segregation												Segregated switchgear					
			D=150mm		D=225mm		D=300mm		D=500mm		D=700mm		D=900mm		D=500mm		D=700mm		D=900mm	
Horiz.		Vertic.		Horiz.		Vertic.		Horiz.		Vertic.		Horiz.		Vertic.		Horiz.		Vertic.		
Tmax XT1	front terminal	fixed	•	•	•	•	•	•	•	•	•	•	•	•	•	•	•	•	•	•
		plug-in																		
		withdrawable																		
		fixed+diff. mod.	•	•	•	•	•	•	•	•	•	•	•	•	•	•	•	•	•	•
	rear terminal	fixed			•	•	•	•	•	•	•	•	•	•	•	•	•	•	•	•
		plug-in																		
		withdrawable																		
		fixed+diff. mod.																		
Tmax XT2	front terminal	fixed	•	•	•	•	•	•	•	•	•	•	•							
		plug-in			•	•	•	•	•	•	•	•	•	•	•	•	•	•	•	
		withdrawable																		
		fixed+diff. mod.																		
	rear terminal	fixed			•	•	•	•	•	•	•	•	•	•	•	•	•	•	•	
		plug-in			•	•	•	•	•	•	•	•	•	•	•	•	•	•	•	
		withdrawable																		
		fixed+diff. mod.																		
Tmax XT3	front terminal	fixed	•	•	•	•	•	•	•	•	•	•	•							
		plug-in																		
		withdrawable																		
		fixed+diff. mod.	•	•	•	•	•	•	•	•	•	•	•	•						
	rear terminal	fixed			•	•	•	•	•	•	•	•	•	•	•	•	•	•	•	
		plug-in			•	•	•	•	•	•	•	•	•	•	•	•	•	•	•	
		withdrawable																		
		fixed+diff. mod.																		
Tmax XT4	front terminal	fixed	•	•	•	•	•	•	•	•	•	•	•							
		plug-in																		
		withdrawable																		
		fixed+diff. mod.	•	•	•	•	•	•	•	•	•	•	•	•						
	rear terminal	fixed			•	•	•	•	•	•	•	•	•	•	•	•	•	•	•	
		plug-in			•	•	•	•	•	•	•	•	•	•	•	•	•	•	•	
		withdrawable			•	•	•	•	•	•	•	•	•	•	•	•	•	•	•	
		fixed+diff. mod.																		

ArTu K Modular Structures

Selection of the structure

Solutions recommended for installation of the apparatus

Apparatus fitted with accessories			Type of structure/installation														
			Switchgear without segregation									Segregated switchgear					
			D=225mm		D=300mm		D=500mm		D=700mm		D=900mm		D=500mm		D=700mm		D=900mm
			Horiz	Vertic	Horiz	Vertic	Horiz	Vertic	Horiz	Vertic	Horiz	Vertic	Horiz	Vertic	Horiz	Vertic	
Direct rotary handle																	
Motor operator																	
Tmax T1	front terminal	fixed	•		•		•		•		•						
Tmax T2	front terminal	fixed	•		•		•		•		•						
	rear terminal	fixed	•		•		•		•		•						
Tmax T3	front terminal	fixed	•		•		•		•		•						
		plug-in	•		•		•		•		•						
	rear terminal	fixed			•		•		•		•		•		•		•
		plug-in			•		•		•		•		•		•		•
Tmax T4	front terminal	fixed	•	•	•		•		•		•						
		plug-in	•		•		•		•		•						
		withdrawable	•	•	•		•		•		•						
	rear terminal	fixed			•		•		•		•		•		•		•
		plug-in			•		•		•		•		•		•		•
		withdrawable			•		•		•		•		•		•		•
Tmax T5	front terminal	fixed	•	•	•	•	•	•	•	•	•	•	•	•	•	•	•
		plug-in	•	•	•	•	•	•	•	•	•	•	•	•	•	•	•
		withdrawable	•	•	•	•	•	•	•	•	•	•	•	•	•	•	•
	rear terminal	fixed			•	•	•	•	•	•	•	•	•	•	•	•	•
		plug-in			•	•	•	•	•	•	•	•	•	•	•	•	•
		withdrawable			•	•	•	•	•	•	•	•	•	•	•	•	•
Tmax T6	front terminal	fixed	•	•	•	•	•	•	•	•	•	•	•	•	•	•	•
		withdrawable			•	•	•	•	•	•	•	•	•	•	•	•	•
	rear terminal	fixed			•	•	•	•	•	•	•	•	•	•	•	•	•
		withdrawable			•	•	•	•	•	•	•	•	•	•	•	•	•
Tmax T7	front terminal	fixed			•		•		•		•						
		withdrawable			•		•		•		•						
	rear terminal	fixed			•	•	•	•	•	•	•	•	•	•	•	•	•
		withdrawable			•	•	•	•	•	•	•	•	•	•	•	•	•
Tmax XT1	front terminal	fixed	•		•		•		•		•						
	rear terminal	fixed			•		•		•		•						
Tmax XT2	front terminal	fixed	•		•		•		•		•						
	rear terminal	fixed			•		•		•		•						
Tmax XT3	front terminal	fixed	•		•		•		•		•						
	rear terminal	fixed			•		•		•		•						

ArTu K Modular Structures

Selection of the structure

Solutions recommended for installation of the apparatus

Apparatus fitted with accessories			Type of structure/installation															
			Switchgear without segregation						Segregated switchgear									
			D=225mm		D=300mm		D=500mm		D=700mm		D=900mm		D=500mm		D=700mm		D=900mm	
			Horiz	Vertic	Horiz	Vertic	Horiz	Vertic	Horiz	Vertic	Horiz	Vertic	Horiz	Vertic	Horiz	Vertic	Horiz	Vertic
Interlocked Interlocked motor operated																		
Tmax T3	front terminal	fixed		•		•		•		•		•						
		plug-in		•		•		•		•		•						
		withdrawable		•		•		•		•		•						
rear terminal	fixed				•		•		•		•		•		•		•	
	plug-in				•		•		•		•		•		•		•	
Tmax T4	front terminal	fixed			•		•		•		•							
		plug-in			•		•		•		•							
	rear terminal	fixed			•		•		•		•		•		•		•	
	plug-in				•		•		•		•		•		•		•	
Tmax T5	front terminal	fixed			•		•		•		•							
		plug-in			•		•		•		•							
		withdrawable			•		•		•		•							
	rear terminal	fixed			•		•		•		•		•	•	•	•	•	•
	plug-in				•		•		•		•		•	•	•	•	•	•
	withdrawable				•		•		•		•		•	•	•	•	•	•
Tmax T6	front terminal	fixed			•		•		•		•							
		withdrawable			•		•		•		•							
	rear terminal	fixed			•		•		•		•			•		•		•
	withdrawable							•		•			•		•		•	
Tmax T7	front terminal	withdrawable						•		•								
	rear terminal	fixed				•		•		•			•		•		•	
		withdrawable							•		•			•		•		•
Tmax XT1	front terminal	fixed	•		•		•		•		•							
		plug-in			•		•		•		•							
	rear terminal	fixed	•		•		•		•		•		•		•		•	
	plug-in					•		•		•								
Tmax XT3	front terminal	fixed	•		•		•		•		•							
		plug-in			•		•		•		•							
	rear terminal	fixed	•		•		•		•		•		•		•		•	
	plug-in					•		•		•								
Tmax XT4	front terminal	fixed	•		•		•		•		•							
		plug-in			•		•		•		•							
	rear terminal	fixed	•		•		•		•		•		•		•		•	
	plug-in					•		•		•								

ArTu K Modular Structures

Kit for installing apparatus

System Pro M modular apparatus Tmax T1-T2-T3 moulded-case circuit-breakers, OT \leq 160 A and Unifix H supports

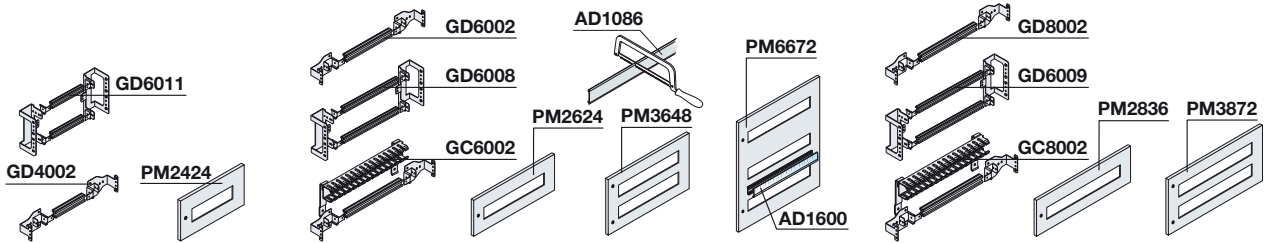

1STC80205FF001

W=390mm			W=600mm				W=800mm		
H (mm)	DIN rail kit 12 DIN mod.	Panel 1 DIN row 12 DIN mod.	DIN rail kit 24 DIN mod.	Panel 1 DIN row 24 DIN mod.	Panel 2 DIN rows 48 DIN mod.	Panel 3 DIN rows 72 DIN mod.	DIN rail kit 36 DIN mod.	Panel 1 DIN row 36 DIN mod.	Panel 2 DIN rows 72 DIN mod.
Standard aluminium version									
200	GD4002	PM2424	GD6002	PM2624			GD8002	PM2836	
300 ⁽²⁾			GD6002	PM2312			GD8002	PM2315	
300 ⁽¹⁾	GD6011	PM3424	GD6008		PM3648		GD6009		PM3872
600			3x GD6002			PM6672			
Version fitted with accessories (complete with 60x80 wiring duct and AD 1037 supports)									
200			GC6002	PM2624			GC8002	PM2836	
Reinforced version for Tmax and Tmax differential RC 221/1 mod. 200mm									
200			GD6010	PM2624			GD8010	PM2836	
Reinforced version for Tmax									
300 ⁽²⁾			GD6010	PM2312			GD8010	PM2315	
Unifix H fixing brackets									
300			AD1061	PM3624			AD1061	PM3836	

⁽¹⁾ Only for System Pro M modular apparatus.

⁽²⁾ Version for Tmax with differential module underplated RC 221/222.

Completion items for installation on DIN rail

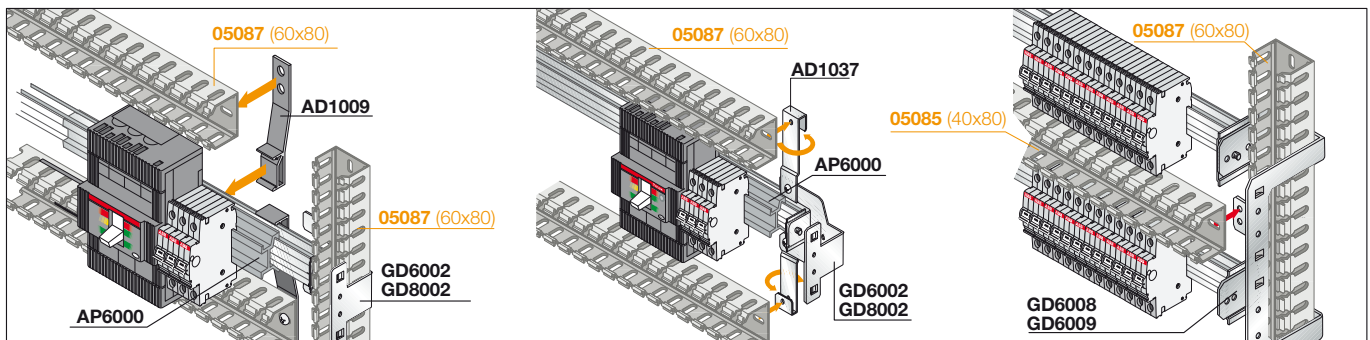

1STC80204MF001

Supports for horizontal wiring duct

Code	Description
AD1009	Horizontal wiring duct (plastic) supports
AD1037	Horizontal wiring duct (metal) supports

Allows assembly of the cabling wiring duct horizontally up to 60x80mm. The AD1009 plastic model can be positioned on the rear of the DIN rail, whereas the AD1037 metal version is fixed onto the brackets of DIN rail GD6002/ GD8002, and allows adjustment of the wiring duct depth.

Depth adapter

Code	Description
AP6000	N°1 depth adapter for Tmax T1-T2-T3-XT1-XT3 W=600mm floor-standing
AP6001	N°1 depth adapter for Tmax T1-T2-T3-XT1-XT3 W=600mm wall-mounting

DIN window hole covers

Code	Description
AD1086	DIN L=2000mm hole cover strip - grey RAL 7035
AD1088	DIN 24 modules hole cover strip - grey RAL 7035
AD1089	DIN 36 modules hole cover strip - grey RAL 7035

Tmax XT Flangers for DIN-Rail mounting

Code	Description
AD3301	XT1 3P Flanger for DIN-Rail mounting
AD3302	XT1 4P Flanger for DIN-Rail mounting
AD3303	XT3 3P Flanger for DIN-Rail mounting
AD3304	XT3 4P Flanger for DIN-Rail mounting

Already supplied in the DIN-Rail mounting kit for breakers in MCCBs catalogue 1SDC210033D0901

For Isomax kits, please see page 9/83.

ArTu K Structures without segregation

Kit for switchgear with reduced frames D=150-225-300mm

Horizontal installation

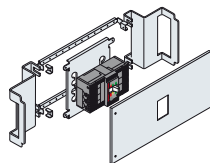

Circuit-breaker front terminals	N° poles	Dimensions H (mm)	Fixed		Fixed + diff. mod. underneath	
			24 DIN mod. W=600mm	36 DIN mod. W=800mm	24 DIN mod. W=600mm	36 DIN mod. W=800mm
Tmax T1	3-4	200	KT1117		KT1102 ⁽¹⁾	
Tmax T1	4	200				
Tmax T2	3-4	200	KT2117		KT2102	KL2103
Tmax T2	4	200				
Tmax T3	3-4	200	KT3112	KL3113	KT3102	KL3103
Tmax T3	4	300				
Tmax T4	3-4	200	KT4112	KL4115	KT4110	KL4116
Tmax T4	4	200				
Tmax T5	3-4	300	KT5112	KL5114	KT5110	KL5116
Tmax T5	4	300				
Tmax T6	3-4	500	KT6113	KL6113		
Tmax XT1	3 ⁽²⁾ /4	200	KX1617			
Tmax XT1 CB + diff. mod.	4	200			KX1602	
Tmax XT2	3 ⁽²⁾ /4	200	KX2619			
Tmax XT2 CB + diff. mod.	4	200			KX2602	
Tmax XT3	3 ⁽²⁾ /4	200	KX3612	KL3613		
Tmax XT3 CB + diff. mod.	4	300			KX3602	KX3603
Tmax XT4	3 ⁽²⁾ /4	200	KX4612	KX4615		
Tmax XT4 CB + diff. mod.	4	200			KX4610	

⁽¹⁾ Version for Tmax with differential module underplaced RC 221/222

⁽²⁾ For 3 poles breakers please order accessory flange codes: **AD3305** XT1 3P Flange for plate-mounting - **AD3306** XT2 3P Flange for plate-mounting - **AD3307** XT3 3P Flange for plate-mounting - **AD3308** XT4 3P Flange for plate-mounting

Vertical installation

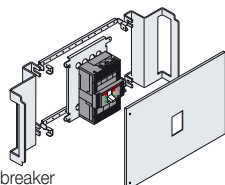

Circuit-breaker front terminals	N° poles	Dimensions H (mm)	Fixed		Fixed + diff. mod. underneath	
			24 DIN mod. W=600mm	36 DIN mod. W=800mm	24 DIN mod. W=600mm	36 DIN mod. W=800mm
			(see page 5/10)			
Tmax T1-T2-T3 on DIN rail 35		200	KT3212			
Tmax T3	3-4	300	KT4212			
Tmax T4	3-4	400			KT4102	
Tmax T4	4	500	KT5212	KL5212		
Tmax T5	3-4	400			KT5102	KL5102
Tmax T5	4	500	KT6213	KL6213		
Tmax T6	3-4	500				
Tmax XT1	3 ⁽¹⁾ /4	200	KX1618			
Tmax XT1 CB + diff. mod.	4	300			KX1603	
Tmax XT1 N 3 CBs side by side	3 ⁽¹⁾ /4	200	KX1604			
Tmax XT3	3 ⁽¹⁾ /4	300	KX3614			
Tmax XT3 CB + diff. mod.	4	300			KX3609	
Tmax XT4	3 ⁽¹⁾ /4	300	KX4614			
Tmax XT4 CB + diff. mod.	4	400			KX4602	

⁽¹⁾ For 3 poles breakers please order accessory flange codes: **AD3305** XT1 3P Flange for plate-mounting - **AD3306** XT2 3P Flange for plate-mounting - **AD3307** XT3 3P Flange for plate-mounting - **AD3308** XT4 3P Flange for plate-mounting

For Isomax kits, please see page 9/83.

ArTu K Structures without segregation

Kit for switchgear with reduced frames D=150-225-300mm

Apparatus of the OETL series up to 400A and OESA up to 160 A (in both cases not motor operated) can be installed inside the floor-mounted ArTu K switchgear. According to the dimensions of the apparatus, a plain back plate must be used (PF or FR...) and a panel (PC or PR...) of appropriate height and depth must be used. The useful space between panel and door is 50mm. For larger-sized handles, use plain recessed panels PR... (see dimensions in table).

Kit for OT125-400

vertical installation

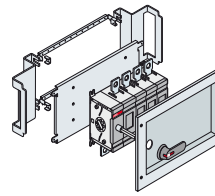

horizontal installation

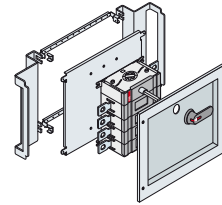

H (mm)	Width (mm)	OT200/250 OT315/400	OT125/160	OT200/250 OT315/400
300	600	KO2260	KO1201	KO2261
300	800	KO2280		KO2281

Plain back plates, plain and ventilated panels

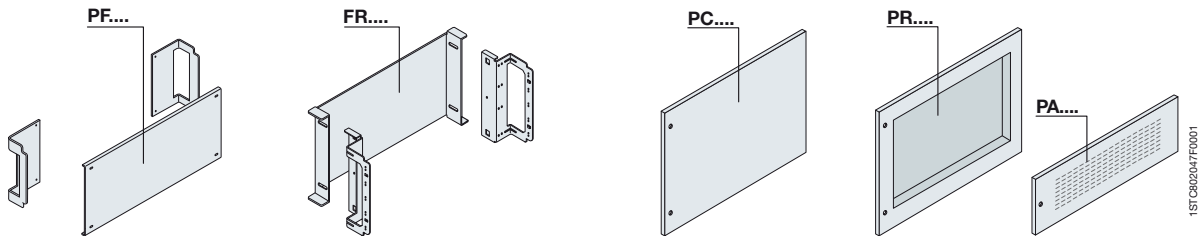

Back plates

H (mm)	Plain flat		Plain recessed	
	24 DIN mod. W=600mm	36 DIN mod. W=800mm	24 DIN mod. W=600mm	36 DIN mod. W=800mm
100				
200	PF2610	PF2810	FR2601	FR2801
300				
400	PF4610	PF4810	FR4601	FR4801
600				
800				
1600				
1800				
2000				

Panels

Plain flat		Plain recessed		Ventilated
24 DIN mod. W=600mm	36 DIN mod. W=800mm	24 DIN mod. W=600mm	36 DIN mod. W=800mm	24 DIN mod. W=600mm
PC1600	PC1800			PA1600
PC2600	PC2800	PR2600	PR2800	PA2600
PC3600	PC3800			
PC4600	PC4800	PR4600	PR4800	
PC6600	PC6800	PR6600	PR6800	
PC8600	PC8800			
PC1660	PC1680			
PC1860	PC1880			
PC2060	PC2080			

Can be used to mount all the non-modular apparatus. Useful dimensions - see page 8/20.

Useful internal space

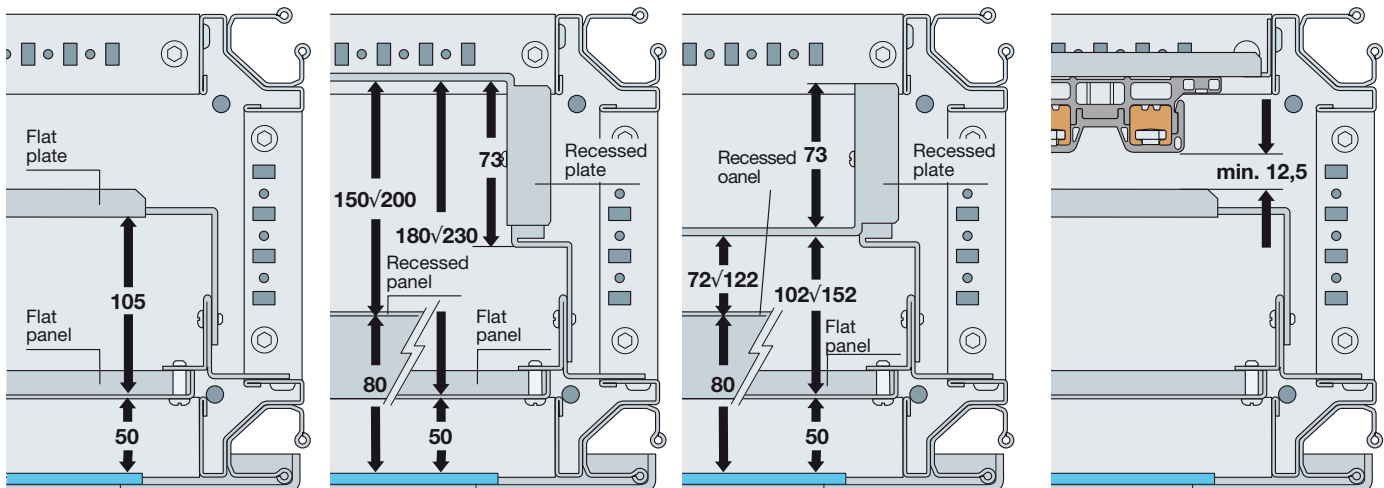

Minimum distance between back plate and busbar holder

ArTu K Structures without segregation

Kit for switchgear with standard frames $D \geq 225\text{mm}$

Horizontal installation

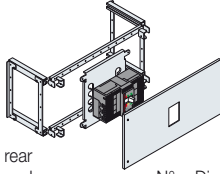

Front or rear circuit-breaker terminals

N° poles Dimensions H (mm)

	N° poles	Dimensions H (mm)	Fixed			Fixed + diff. mod. underneath			Plug-in		Withdrawable	
			12 DIN mod. W=390mm	24 DIN mod. W=600mm	36 DIN mod. W=800mm	12 DIN mod. W=390mm	24 DIN mod. W=600mm	36 DIN mod. W=800mm	12 DIN mod. W=390mm	24 DIN mod. W=600mm	12 DIN mod. W=390mm	24 DIN mod. W=600mm
Tmax T1	3-4	200	KT1411	KT1111		KT1401 ⁽¹⁾	KT1101 ⁽¹⁾	KL1102 ⁽¹⁾				
Tmax T1	4	200										
Tmax T2	3-4	200	KT2411	KT2111		KT2401	KT2101	KL2104	KT2421	KT2121		
Tmax T2	4	200 ⁽¹⁾										
Tmax T3	3-4	200	KT3419	KT3119	KL3114	KT3401	KT3101	KL3104	KT3421	KT3121		
Tmax T3	4	300 ⁽¹⁾										
Tmax T4	3-4	200	KT4411	KT4111					KT4122			
Tmax T4	3-4	300										KT4127
Tmax T4	4	200					KT4101					
Tmax T5 (400A)	3-4	300	KT5411	KT5111	KL5115				KT5120			KT5130
Tmax T5 (630A)	3-4	300	KT5411	KT5111	KL5115				KT5121			KT5131
Tmax T5	4	300					KT5101	KL5101				
Tmax T6	3-4	500			KT6111							KT6131
Tmax T7-Emax X1	3-4	400	KT7110 ⁽²⁾	KT7111	KL7112							
Tmax XT1	3 ⁽³⁾ /4	200	KX1419	KX1611								
Tmax XT1 CB + diff. mod.	4	200 ⁽¹⁾					KX1609	KX1801				
Tmax XT2	3 ⁽³⁾ /4	200	KX2411	KX2611						KX2621		
Tmax XT2 CB + diff. mod.	4	200 ⁽¹⁾					KX2601	KX2801				
Tmax XT3	3 ⁽³⁾ /4	200	KX3411	KX3611	KX3811						KX3621	
Tmax XT3 CB + diff. mod.	4	300 ⁽¹⁾					KX3601	KX3801				
Tmax XT4	3 ⁽³⁾ /4	200	KX4411	KX4611						KX4622		
Tmax XT4	3 ⁽³⁾ /4	300										KX4627
Tmax XT4 CB + diff. mod.	4	200 ⁽¹⁾					KX4601					

⁽¹⁾ Version for Tmax with differential module underplaced RC 221/222 ⁽²⁾ Only rear terminals

⁽³⁾ For 3 poles breakers please order accessory flange codes: **AD3305** XT1 3P Flange for plate-mounting - **AD3306** XT2 3P Flange for plate-mounting - **AD3307** XT3 3P Flange for plate-mounting - **AD3308** XT4 3P Flange for plate-mounting

Vertical installation

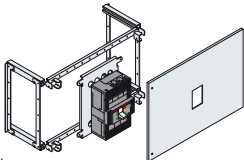

Front or rear circuit-breaker terminals

N° poles Dimensions H (mm)

	N° poles	Dimensions H (mm)	Fixed			Fixed + diff. mod. underneath			Plug-in		Withdrawable		
			12 DIN mod. W=390mm	24 DIN mod. W=600mm	36 DIN mod. W=800mm	12 DIN mod. W=390mm	24 DIN mod. W=600mm	36 DIN mod. W=800mm	12 DIN mod. W=390mm	24 DIN mod. W=600mm	12 DIN mod. W=390mm	24 DIN mod. W=600mm	
Tmax T1-T2-T3 on DIN 35 rail	3-4	200	(see page 5/10)										
Tmax T3	3-4	300	KT3416	KT3211	KL3212								
Tmax T3	3-4	400							KT3426	KT3221			
Tmax T4	3-4	400	KT4412	KT4211						KT4221	KT4231	KT4231	
Tmax T4 side by side	3-4	400		KT4116 ⁽⁵⁾	KL4118 ⁽⁵⁾								
Tmax T4	4	500					KT4103						
Tmax T5 (400A)	3-4	400	KT5412	KT5211	KL5213					KT5222	KT5232	KT5232	
Tmax T5	3-4	400	KT5412	KT5211	KL5213								
Tmax T5 side by side	3-4	400		KT5214 ⁽⁴⁾	KL5214 ⁽⁵⁾								
Tmax T5	3-4	500							KT5221	KT5231	KT5231		
Tmax T5	4	500					KT5401	KT5103	KL5103				
Tmax T5 side by side	3-4	500						KT5117 ⁽⁴⁾	KL5117 ⁽⁵⁾				
Tmax T6	3-4	500		KT6211	KL6214						KT6122	KT6122	
Tmax T6	3-4	500			KL6124								
Tmax T6 side by side	3-4	500											
Tmax T7-EMAX X1	3-4	500		KT7211 ⁽⁶⁾	KL7212 ⁽⁶⁾						KT7231 ⁽⁶⁾	KT7231 ⁽⁶⁾	
Isomax S8	3-4	900		KS8211									
Tmax XT3	3 ⁽⁷⁾ /4	300	KX3412	KX3613	KX3812								
Tmax XT4	3 ⁽⁷⁾ /4	300	KX4412	KX4617									
Tmax XT4 CB + diff. mod.	4	400					KX4603						
Tmax XT4 N 2 CBs side by side	3 ⁽⁷⁾ /4	300		KX4616									
Tmax XT4 N 3 CBs side by side	3 ⁽⁷⁾ /4	300			KX4818								

⁽¹⁾ Only front terminals,

⁽²⁾ Only rear terminals,

⁽³⁾ Kit for n° 4 T4 circuit-breakers side by side,

⁽⁴⁾ Kit for n° 2 circuit-breakers side by side,

⁽⁵⁾ Kit for n° 3 circuit-breakers side by side,

⁽⁶⁾ Order N°2 blind panels H=100mm (PC....) for breakers with front terminals.

⁽⁷⁾ For 3 poles breakers please order accessory flange codes: **AD3305** XT1 3P Flange for plate-mounting - **AD3306** XT2 3P Flange for plate-mounting - **AD3307** XT3 3P Flange for plate-mounting - **AD3308** XT4 3P Flange for plate-mounting

For Isomax kits, please see page 9/83.

Selection by componentspage 9/51

In-depth technical informationpage 6/10

Overall dimensionspage 8/14

ArTu K Structures without segregation

Kit for switchgear with standard frames $D \geq 225\text{mm}$

Horizontal installation

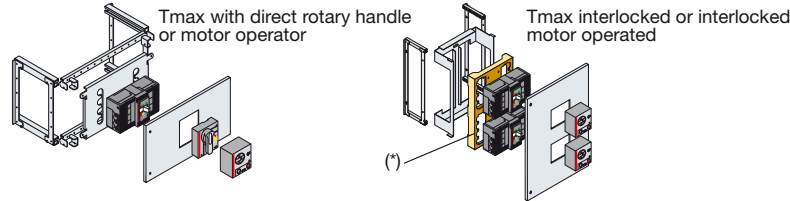

Front or rear circuit-breaker terminals	N° poles	Dimensions H (mm)	Fixed				Plug-in				Withdrawable					
			24 DIN mod. W=600mm				24 DIN mod. W=600mm				24 DIN mod. W=600mm					
			Direct rotary handle	Motor operator	Interlocked	Direct rotary handle	Direct rotary handle	Motor operator	Interlocked	Direct rotary handle	Direct rotary handle	Motor operator	Interlocked	Direct rotary handle		
Tmax T1	3-4	200	KT1112	KT1111												
Tmax T2	3-4	200	KT2112	KT2111												
Tmax T3	3-4	200	KT3114	KT3119				KT3116	KT3121							
Tmax T3	3-4	600			KT3131	KT3131										
Tmax T4	3-4	200	KT4111	KT4111												
Tmax T4	3-4	300										KT4127	KT4125			
Tmax T4	3-4	600			KI4114	KI4114				KI4114	KI4114			KI4115	KI4115	
Tmax T5 (400A)	3-4	300	KT5111	KT5111								KT5130	KT5134			
Tmax T5 (630A)	3-4	300	KT5111	KT5111								KT5131	KT5135			
Tmax T5	3-4	600			KI5114	KI5114				KI5114	KI5114			KI5115	KI5115	
Tmax T6	3-4	500	KT6112	KT6115								KT6131	KT6114			
Tmax T6	3-4	800			KT6116⁽²⁾	KT6117⁽²⁾								KT6118	KT6119	
Tmax T7** - Emax X1	3-4	400	KT7111⁽¹⁾	KT7111⁽¹⁾	KT7111⁽¹⁾	KT7111⁽¹⁾										
Tmax XT1	3/4	200	KX1605													
Tmax XT2	3/4	200	KX2605													
Tmax XT3	3/4	200	KX3605													
Tmax XT3+XT1	3 ⁽³⁾ /4	500			KX1131					KX1131						
Tmax XT3	3 ⁽³⁾ /4	500			KX3131					KX3131						
Tmax XT4	3 ⁽³⁾ /4	500			KX4141					KX4141						

⁽¹⁾ Interlock plate to be ordered with the circuit-breakers. ^(*) Kit for a single circuit-breaker. ⁽¹⁾ Kit for width 800mm **KL7112**. ⁽²⁾ Use with rear connection. ⁽³⁾ For 3 poles breakers please order accessory flange codes: **AD3305** XT1 3P Flange for plate-mounting - **AD3306** XT2 3P Flange for plate-mounting - **AD3307** XT3 3P Flange for plate-mounting - **AD3308** XT4 3P Flange for plate-mounting

Vertical installation

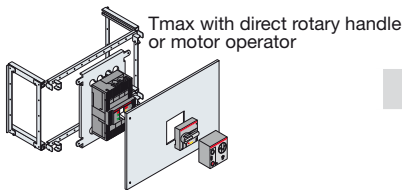

Front or rear circuit-breaker terminals	N° poles	Dimensions H (mm)	Fixed				Plug-in				Withdrawable					
			24 DIN mod. W=600mm				24 DIN mod. W=600mm				24 DIN mod. W=600mm					
			Direct rotary handle	Motor operator	Interlocked	Direct rotary handle	Direct rotary handle	Motor operator	Interlocked	Direct rotary handle	Direct rotary handle	Motor operator	Interlocked	Direct rotary handle		
Tmax T4	3-4	400	KT4211	KT4211								KT4231	KT4126			
Tmax T5 (400A)	3-4	400	KT5211	KT5211								KT5232	KT5138			
Tmax T5 (630A)	3-4	400	KT5211	KT5211												
Tmax T5	3-4	500										KT5231	KT5139			
Tmax T6	3-4	500	KT6120	KT6121								KT6122	KT6123			
Tmax T7** - Emax X1	3-4	500		KT7211⁽²⁾	KT7211⁽²⁾	KT7211⁽²⁾							KT7231⁽³⁾	KT7231⁽³⁾	KT7231⁽³⁾	

^(*) Kit for a single circuit-breaker. ⁽¹⁾ Only rear terminals. ⁽²⁾ Kit for width 800mm **KL7212**. ⁽³⁾ Kit for width 800mm **KL7213**.

For Isomax kits, please see page 9/83.

Selection by componentspage 9/51

In-depth technical informationpage 6/10

Overall dimensionspage 8/14

ArTu K Structures without segregation

Kit for switchgear with standard frames $D \geq 225\text{mm}$

Vertical installation

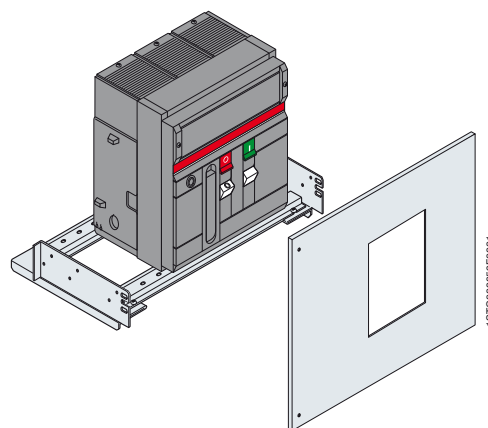

Circuit-breaker	N° poles	Dimensions H (mm)	Fixed		Withdrawable	
			24 DIN mod. W=600mm	36 DIN mod. W=800mm	24 DIN mod. W=600mm	36 DIN mod. W=800mm
Emax X1/X1 interlocked**	3-4	500	KT7211⁽¹⁾	KL7212⁽¹⁾	KT7231⁽¹⁾	KL7213⁽¹⁾
Emax E1⁽¹⁾-E2⁽¹⁾-E3	3-4	600	KE3215		KE3235	
Emax E3/E3 interlocked**	3-4	600		KE4215		KE4235
Emax E4/E4 interlocked**	3-4	600		KE5215		KE5235

The kit for installing Emax air circuit-breakers in the versions of switchgear indicated includes the pre-drilled front panel and the resting crosspieces. To install Emax E1...E3 circuit-breakers, always use 700mm depth (therefore also depth 900mm with kit SK..81), for Emax E4 use structures with 900mm depth or several structures placed side by side at the rear.

⁽¹⁾ This kit can also be used for motor operated, interlocked and interlocked motor operated version.

^(*) Kit for a single circuit-breaker.

Useful internal space

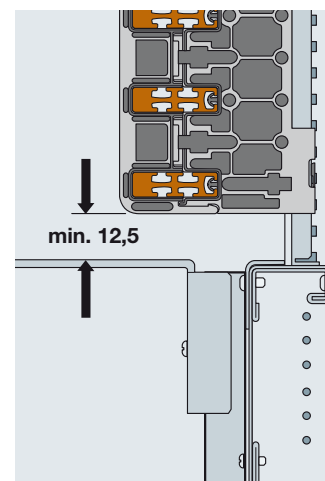
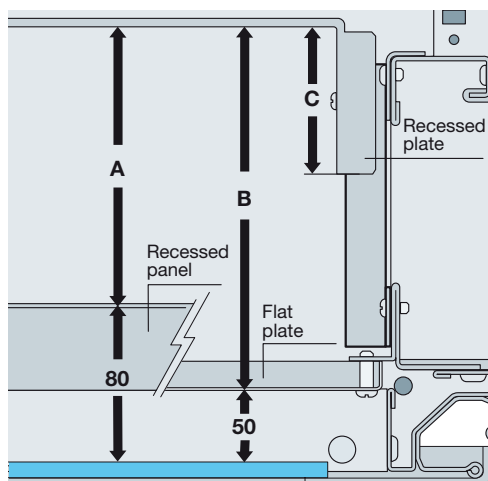
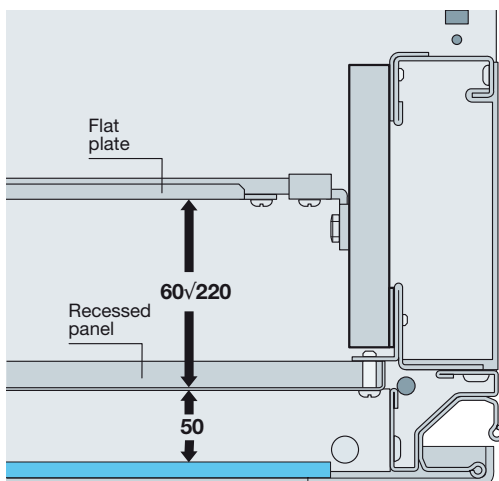

Structure	H recessed plate (mm)	A (mm)	B (mm)	C (mm)
ArTu K D" 300mm	200	45v220	75v250	28
	400	110v220	140v250	95
ArTu K D \geq 500mm	200	45v200	75v230	28
	400	110v270	140v300	95
	600	250v380	280v410	240

ArTu K Structures without segregation

Kit for switchgear with standard frames $D \geq 225\text{mm}$

Apparatus of the OETL series up to 1600A (not motor operated) and OESA up to 800A (not motor operated) can be installed inside the floor-mounted ArTu K switchgear.

Again in this case, according to the dimensions of the apparatus, a plain back plate must be used (PF or FR...) and a panel (PC or PR...) of appropriate height and depth.

The useful space between panel and door is 50mm. For larger-sized handles, use plain recessed panels RR... (see dimensions in table).

Kit for OT125+1600

vertical installation

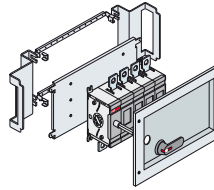

horizontal installation

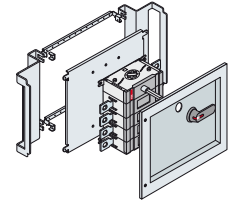

H (mm)	Width (mm)	OT200/250 OT315/400	OT125 OT160	OT630 OT800	OETL1000 OETL1600	OT200/250 OT315/400
300	600	KO2260	KO1201			KO2261
300	800	KO2280				KO2281
400	600			KO3660		
400	800			KO3680		
600	600				KO1251^(*)	

^(*) with recessed panel

Plain back plates, plain and ventilated panels

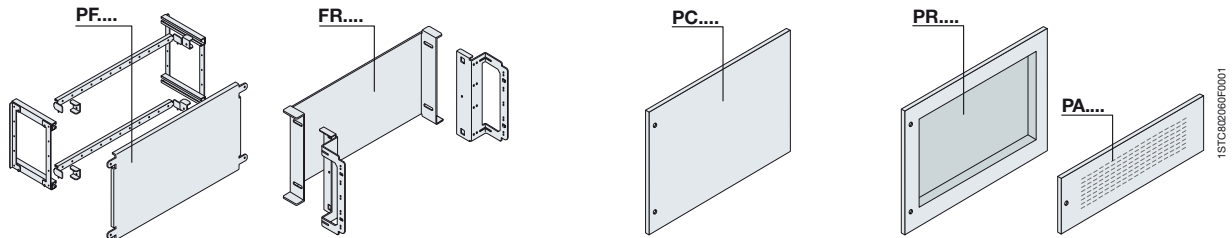

Back plates

Panels

H (mm)	Plain flat			Plain recessed		Plain flat			Plain recessed		Ventilated
	12 DIN mod. W=390mm	24 DIN mod. W=600mm	36 DIN mod. W=800mm	24 DIN mod. W=600mm	36 DIN mod. W=800mm	12 DIN mod. W=390mm	24 DIN mod. W=600mm	36 DIN mod. W=800mm	24 DIN mod. W=600mm	36 DIN mod. W=800mm	24 DIN mod. W=600mm
100						PC1400	PC1600	PC1800			PA1600
200	PF2401	PF2601	PF2801	FR2600	FR2800	PC2400	PC2600	PC2800	PR2600	PR2800	PA2600
300	PF3403	PF3601	PF3801			PC3400	PC3600	PC3800			
400	PF4401	PF4601	PF4801	FR4600	FR4800	PC4400	PC4600	PC4800	PR4600	PR4800	
600	PF6401	PF6601	PF6801	FR6600	FR6800	PC6400	PC6600	PC6800	PR6600	PR6800	
800							PC8600	PC8800			
Counter-door or whole blind panels											
1600							PC1660	PC1880			
1800						PC1840	PC1860	PC1880			
2000						PC2040	PC2060	PC2080			

Can be used to mount all the non-modular apparatus. Useful dimensions - see page 8/20.

Back plates

Pair of crosspieces included in codes **AD1049**, **AD1050**, **AD1051**

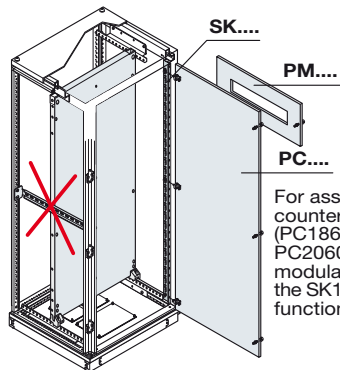
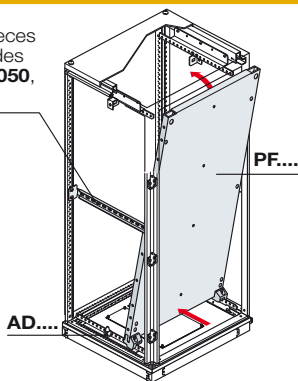

Useful internal space

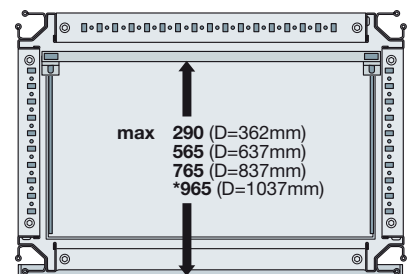

* With rail mounted fully at the back.

Galvanised sheet back plate

H (mm)	24 DIN mod. W=600mm	36 DIN mod. W=800mm
1800	PF1806	PF1808
2000	PF2006	PF2008

Track for front insertion

D=362mm	D=637mm	D=837mm
AD1049	AD1050	AD1051

ArTu K Structures without segregation

Kit for switchgear with standard frames $D \geq 225\text{mm}$

Panels for square measuring instruments

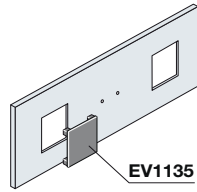

2-instrument panel

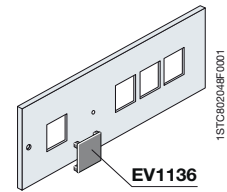

4-instrument panel

H (mm)	72x72mm		96x96mm		72x72mm		96x96mm	
	24 DIN mod. W=600mm	36 DIN mod. W=800mm	24 DIN mod. W=600mm	36 DIN mod. W=800mm	24 DIN mod. W=600mm	36 DIN mod. W=800mm	24 DIN mod. W=600mm	36 DIN mod. W=800mm
200	PS2720	PS2728	PS2960	PS2968	PS4720	PS4728	PS4960	PS4968

These allow installation of measuring instruments and relative changeover switches.

Square instrument hole covers

Code	Description
EV1135	Hole cover of 72x72mm instrument black RAL 9005
EV1136	Hole cover of 96x96mm instrument black RAL 9005

Installation of terminal boxes on DIN rail

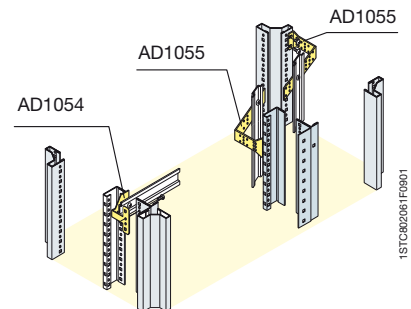
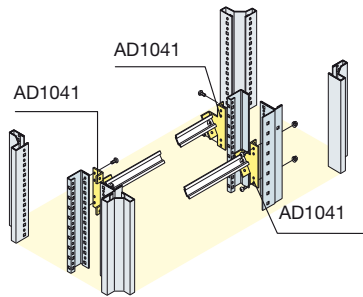

Terminal box mounting position

Installation on DIN rail
Horizontal
Horizontal angled 45°
Vertical

Structure	Internal cable container	External cable container
AD1054		
AD1041		
	AD1055	AD1055

Installation of terminal boxes on DIN rail and earthing busbar

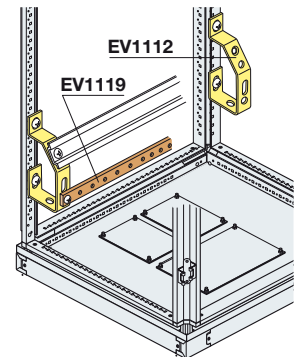
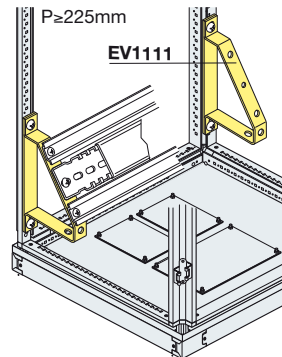
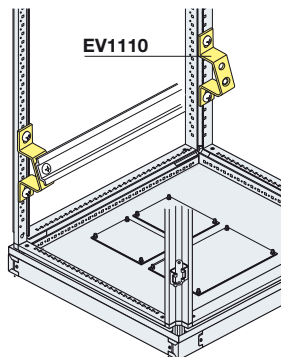

Angled supports for terminal boxes and earthing busbar

Code	Description
EV1110-EV2110	Angled supports 1 row of terminals
EV1111	Angled supports double row of terminals
EV1112-EV2112	Angled supports 1 row of terminals + earth

ArTu K segregated structures

Kit for switchgear with segregated frames $D \geq 500\text{mm}$

Installation on DIN rail

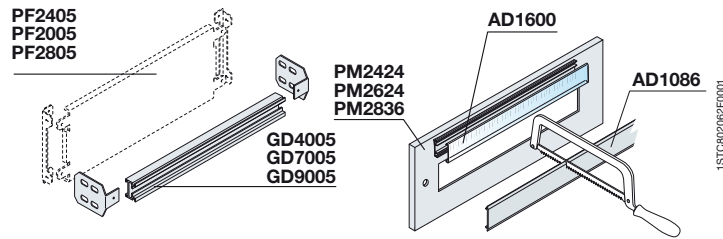

	W=390mm		W=600mm		W=800mm	
H (mm)	DIN rail kit 12 DIN mod.	Panel 1 DIN row 12 DIN mod.	DIN rail kit 24 DIN mod.	Panel 1 DIN row 24 DIN mod.	DIN rail kit 36 DIN mod.	Panel 1 DIN row 36 DIN mod.
200	GD4005	PM2424	GD7005	PM2624	GD9005	PM2836

Back plates, square measuring instrument panels and blind panels

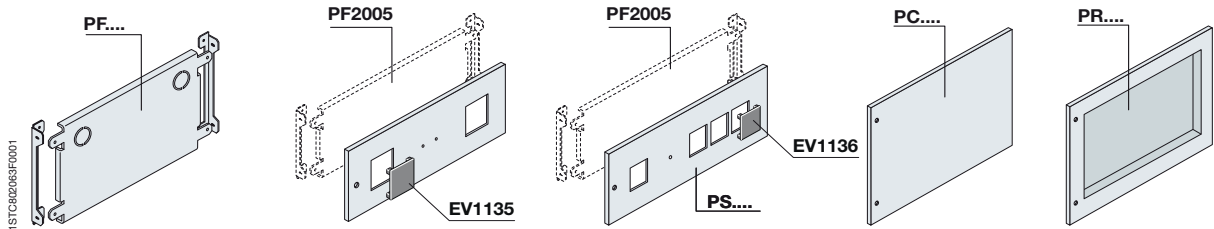

H (mm)	Back plates			Instrument support panels				Blind panels			
	12 DIN mod. W=390mm	24 DIN mod. W=600mm	36 DIN mod. W=800mm	2 instruments		4 instruments		flat			recessed
				72x72mm 24 DIN mod. W=600mm	96x96mm 24 DIN mod. W=600mm	72x72mm 24 DIN mod. W=600mm	96x96mm 24 DIN mod. W=600mm	12 DIN mod. W=390mm	24 DIN mod. W=600mm	36 DIN mod. W=800mm	24 DIN mod. W=600mm
100								PC1400	PC1600	PC1800	
200	PF2405	PF2005	PF2805	PS2720	PS2960	PS4720	PS4960	PC2400	PC2600	PC2800	PR2600
300	PF3405	PF3005	PF3805					PC3400	PC3600	PC3800	
400	PF4405	PF4005	PF4805					PC4400	PC4600	PC4800	PR4600
600	PF6405	PF6005	PF6805					PC6400	PC6600	PC6800	PR6600
800		PF8005	PF8805					PC8600	PC8800		

These allow installation of measuring instruments with dimensions of 72x72mm and 96x96mm. They are available in the versions for two or four instruments and relative change-over switches.

Useful internal space

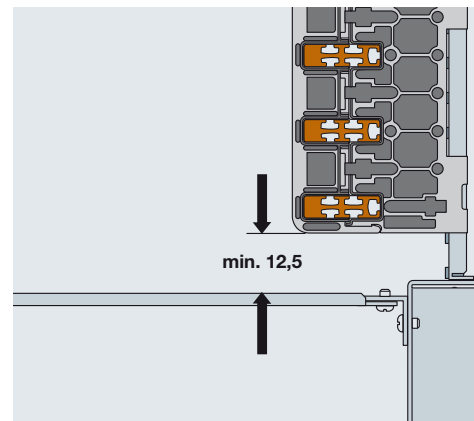
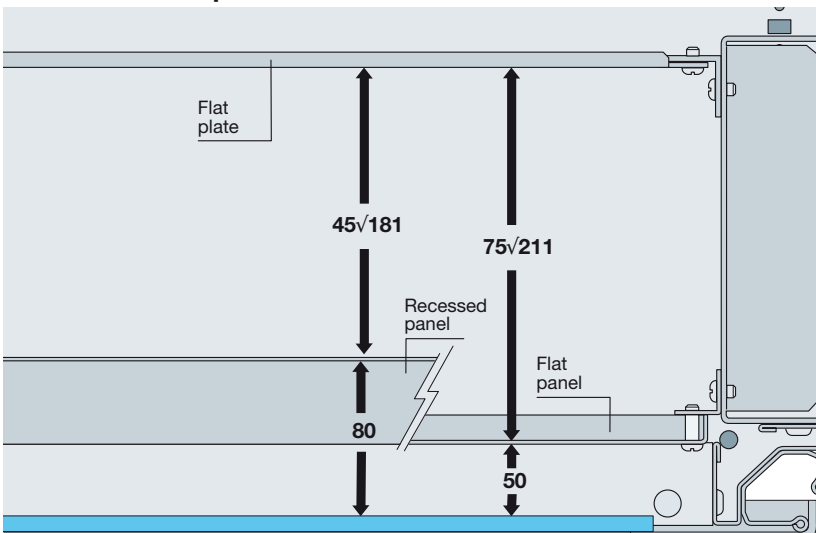

Minimum distance between back plate and busbar holder.

ArTu K segregated structures

Kit for switchgear with segregated frames $D \geq 500\text{mm}$

Horizontal installation

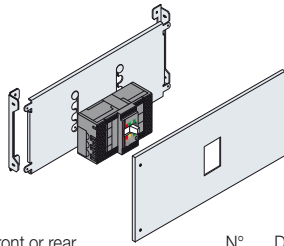

Front or rear circuit-breaker terminals	N° poles	Dimensions H (mm)	Fixed		Fixed+diff. mod undern.	Plug-in		Withdrawable	
			12 DIN mod W=390mm	24 DIN mod W=600mm	24 DIN mod W=600mm	12 DIN mod W=390mm	24 DIN mod W=600mm	12 DIN mod W=390mm	24 DIN mod W=600mm
Tmax T1	3-4	200	KT1410	KT1110	KT1100 ⁽¹⁾				
Tmax T2	3-4	200	KT2410	KT2110		KT2420	KT2120		
Tmax T3	3-4	200	KT3410	KT3110		KT3420	KT3120		
Tmax T4	3-4	200	KT4120	KT4124			KT4113		
Tmax T4	3-4	300							KT4130
Tmax T5 (400A)	3-4	300	KT5122	KT5136			KT5420		KT5430
Tmax T5 (630A)	3-4	300	KT5122	KT5136			KT5421		KT5431
Tmax T6	3-4	500		KT6110					KT6130
Tmax T7 - Emax X1	3-4	400		KT7115					
Tmax XT1	3 ⁽²⁾ /4	200	KY1411	KY1611					
Tmax XT1 CB + diff. mod.	4	200			KY1601				
Tmax XT2	3 ⁽²⁾ /4	200	KY2411	KY2611		KY2421	KY2621		
Tmax XT3	3 ⁽²⁾ /4	200	KY3411	KY3611					
Tmax XT3	3 ⁽²⁾ /4	300				KY3421	KY3621		
Tmax XT4	3 ⁽²⁾ /4	200	KY4411	KY4611			KY4621		
Tmax XT4	3 ⁽²⁾ /4	300							KY4631

⁽¹⁾ Version for Tmax with differential module underplaced RC 221/222 (only 4P)

⁽²⁾ For 3 poles breakers please order accessory flange codes: **AD3305** XT1 3P Flange for plate-mounting - **AD3306** XT2 3P Flange for plate-mounting - **AD3307** XT3 3P Flange for plate-mounting - **AD3308** XT4 3P Flange for plate-mounting.

Vertical installation

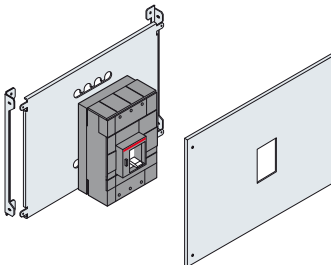

Front or rear circuit-breaker terminals	N° poles	Dimensions H (mm)	Fixed			Plug-in		Withdrawable	
			12 DIN mod W=390mm	24 DIN mod W=600mm	36 DIN mod W=800mm	12 DIN mod W=390mm	24 DIN mod W=600mm	12 DIN mod W=390mm	24 DIN mod W=600mm
Tmax T4	3-4	400	KT4129	KT4121			KT4222		KT4128
Tmax T5 (400A)	3-4	400	KT5137	KT5128			KT5129		KT5223
Tmax T5 (630A)	3-4	400	KT5137	KT5128		KT5125	KT5123	KT5126	KT5124
Tmax T6	3-4	500		KT6210					KT6230
Tmax T7	3-4	500		KT7215					KT7230
Isomax S8	3-4	900			KT8210				
Tmax XT4	3 ⁽¹⁾ /4	300	KY4412	KY4612					

⁽¹⁾ For 3 poles breakers please order accessory flange codes: **AD3305** XT1 3P Flange for plate-mounting - **AD3306** XT2 3P Flange for plate-mounting - **AD3307** XT3 3P Flange for plate-mounting - **AD3308** XT4 3P Flange for plate-mounting.

For Isomax kits, please see page 9/83.

ArTu K segregated structures

Kit for switchgear with segregated frames $D \geq 500\text{mm}$

Horizontal installation

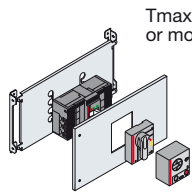

Tmax with direct rotary handle or motor operator

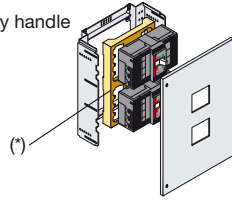

Tmax interlocked or interlocked motor operated

Front or rear circuit-breaker terminals	N° poles	Dimensions H (mm)	Fixed				Plug-in				Withdrawable				
			24 DIN mod. W=600mm				24 DIN mod. W=600mm				24 DIN mod. W=600mm				
			Direct rotary handle	Motor operator	Interlocked	Direct rotary handle	Direct rotary handle	Motor operator	Interlocked	Direct rotary handle	Direct rotary handle	Motor operator	Interlocked	Direct rotary handle	
Tmax T1	3-4	200		KT1110⁽¹⁾											
Tmax T2	3-4	200	KT2210	KT2110⁽¹⁾											
Tmax T3	3-4	200	KT3115	KT3110⁽¹⁾				KT3124							
Tmax T3	3-4	600			KT3132	KT3132									
Tmax T4	3-4	200	KT4124	KT4310				KT4113							
Tmax T4	3-4	300								KT4130	KT4320⁽²⁾				
Tmax T4	3-4	600			KI4116	KI4116			KI4116	KI4119			KI4117	KI4118	
Tmax T5 (400A)	3-4	300	KT5136	KT5310				KT5420				KT5430	KT5320⁽²⁾		
Tmax T5 (600A)	3-4	300	KT5136	KT5310				KT5421				KT5431	KT5321⁽²⁾		
Tmax T5	3-4	600			KI5116	KI5116			KI5116	KI5119			KI5117	KI5118	
Tmax T6	3-4	500	KT6220	KT6221								KT6130	KT6134⁽²⁾		
Tmax T6	3-4	800			KT6142	KT6143								KT6144	KT6145
Tmax T7** - Emax X1	3-4	400	KT7115⁽³⁾	KT7115	KT7115	KT7115									
Tmax XT2	3/4	200	KY2605												
Tmax XT3	3/4	200	KY3605												
Tmax XT3 + XT1	3 ⁽⁴⁾ /4	500			KY1131										
Tmax XT3	3 ⁽⁴⁾ /4	500			KY3131										
Tmax XT4	3 ⁽⁴⁾ /4	500			KY4141										
Tmax XT4	3/4	200		KY4604											

⁽¹⁾ Interlock plate to be ordered with the circuit-breakers. ^(*) Kit for a single circuit-breaker. ⁽¹⁾ Kit for 390mm width for T1 **KT1410**, T2 **KT2410**, T3 **KT3410**. ⁽²⁾ Only Form 2 segregation. ⁽³⁾ Use with protruding door **PV.63 - PV.83**. ⁽⁴⁾ For 3 poles breakers please order accessory flange codes: **AD3305** XT1 3P Flange for plate-mounting - **AD3306** XT2 3P Flange for plate-mounting - **AD3307** XT3 3P Flange for plate-mounting - **AD3308** XT4 3P Flange for plate-mounting.

Vertical installation (only Form 2)

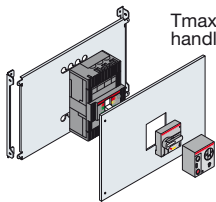

Tmax with direct rotary handle or motor operator

Front or rear circuit-breaker terminals	N° poles	Dimensions H (mm)	Fixed				Plug-in				Withdrawable				
			24 DIN mod. W=600mm				24 DIN mod. W=600mm				24 DIN mod. W=600mm				
			Direct rotary handle	Motor operator	Interlocked	Direct rotary handle	Direct rotary handle	Motor operator	Interlocked	Direct rotary handle	Direct rotary handle	Motor operator	Interlocked	Direct rotary handle	
Tmax T6	3-4	500	KT6132	KT6133								KT6230	KT6141		
Tmax T7** - Emax X1	3-4	500		KT7215	KT7215	KT7215							KT7230	KT7230	KT7230

^(*) Kit for a single circuit-breaker.

For Isomax kits, please see page 9/83.

ArTu K segregated structures

Kit for switchgear with segregated frames $D \geq 500\text{mm}$

Vertical installation

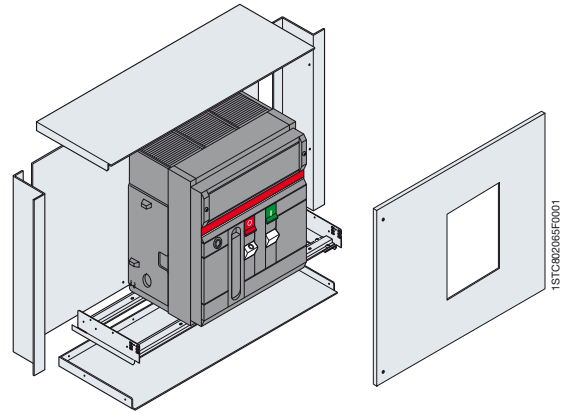

Circuit-breaker	N° poles	Dimensions H (mm)	Fixed		Withdrawable	
			24 DIN mod. W=600mm	36 DIN mod. W=800mm	24 DIN mod. W=600mm	36 DIN mod. W=800mm
Emax X1/X1 interlocked**	3-4	500	KT7215⁽¹⁾		KT7230⁽²⁾	
Emax E1-E2	3-4	600	KE2215		KE2235	
Emax E3	3-4	600	KE3205		KE3236	
Emax E3/E3 interlocked**	3-4	600		KE4214		KE4234
Emax E4/E4 interlocked**	3-4	600		KE5214		KE5234

The kit for installing Emax air circuit-breakers in the versions of switchgear indicated includes the pre-drilled front panel and the resting crosspieces. To install Emax E1...E3 circuit-breakers, always use with 700mm depth (therefore also depth 900mm with kit SK..81), for Emax E4 use structures with 900mm depth or several structures placed side by side at the rear.

To complete the 36 module structure, ask for the special back plates (PF... see pag. 5/20).

⁽¹⁾ This kit can also be used for the motor operated version.

⁽²⁾ This kit can also be used for the motor operated, interlocked and interlocked motor operated versions.

^(*) Kit for a single circuit-breaker.

ArTu K segregated structures

Form 2-3-4 segregations for structures $D \geq 500\text{mm}$

Segregations according to the IEC 60439-1 and IEC 61439 -1 -2 Standards

By form of segregation, the type of subdivision provided inside the switchgear is meant. Segregation by means of barriers or partitions (metallic or insulating) can have the purpose of:

- Ensuring protection against direct contacts (at least IPXXB), in the case of accessing a part of the switchgear with the power turned off, in relation to the rest of the switchgear left live.

- Reducing the probability of an internal arc striking and propagating.
- Preventing passage of solid bodies between different parts of the switchgear (at least IP2X degree of protection).

By partition, the separation element between two compartments is meant, whereas the barrier protects the operator against direct contacts and the effects of an arc of the breaking apparatus in the normal access direction.

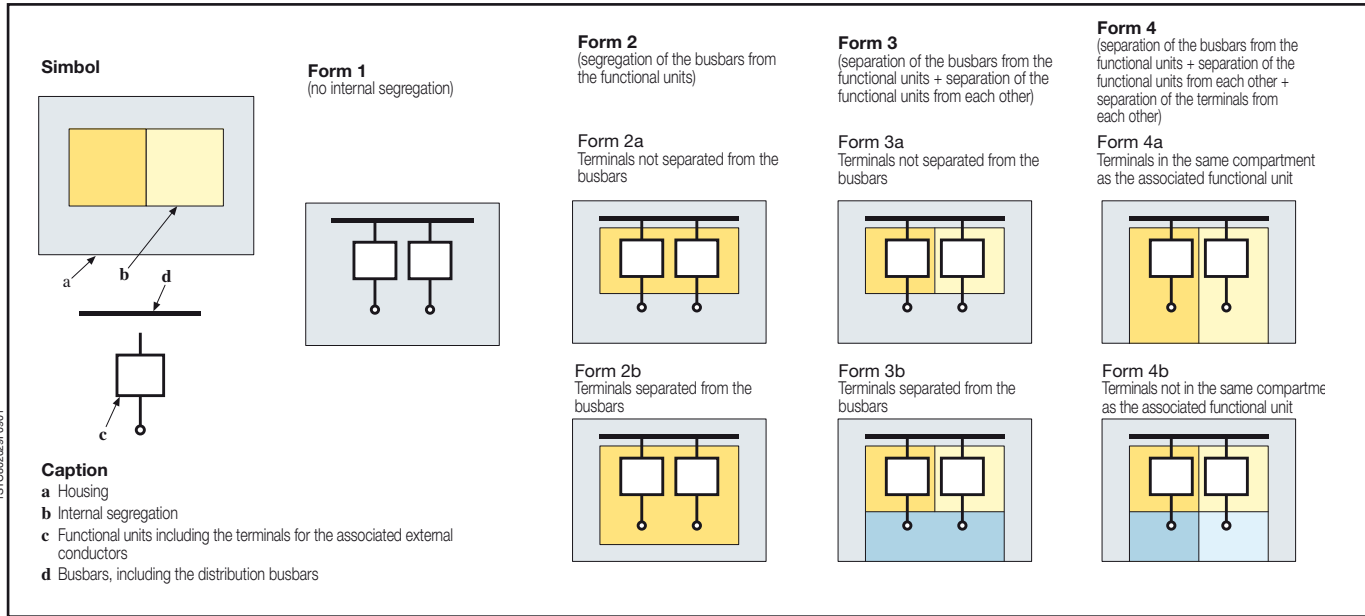

Note

The segregations can be made in ArTu K 390 and 600mm wide switchgear in 500/700/900mm depths with closed functional frame and segregated kits.

Form 2 is obtained automatically using the segregated type kits.

To obtain the desired form of segregation, the segregations kits relative to the previous forms must be ordered (e.g. Form 4 = Form 2 kit + Form 3 kit + Form 4 kit).

ArTu K segregated structures

Form 2-3-4 segregations for structures $D \geq 500\text{mm}$

Examples of segregation

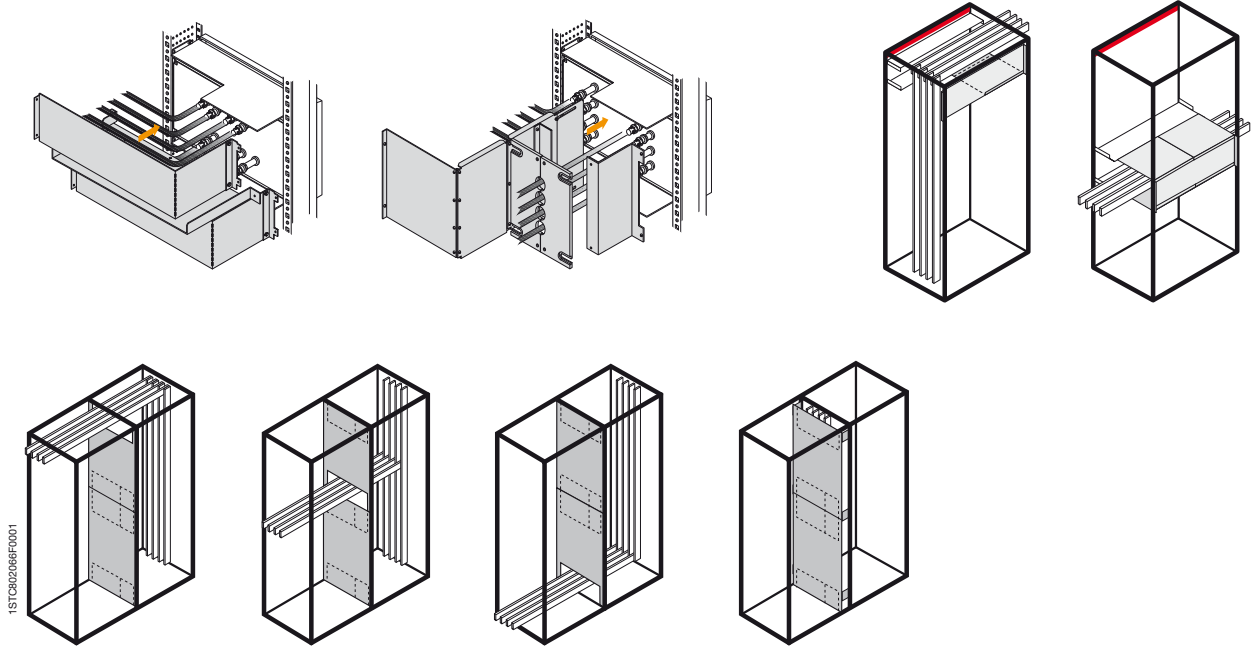



ArTu K segregated structures

Form 2-3-4 segregations for structures D≥500mm

Forms of segregation

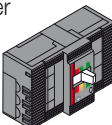

Selection of segregation according to the height of the kit

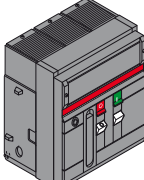
Installation	Height kit (mm)			12 DIN mod.	24 DIN mod.	36 DIN mod.
				W=390mm	W=600mm	W=800mm
Horizontal moulded-case circuit-breaker 	200		See kit on page 5/20	SH4000	SH6000	SH8000
	300					
	400					
	500		See kit on page 5/21			
	600					
	600	T4-T5 interlocked				
800						
Vertical moulded-case circuit-breaker 	200		See kit on page 5/19	SH4000	SH6000	SH8000
	400					
	500	Emax X1-Tmax T7 fixed	See kit on page 5/20			
	600					
	800					
Vertical air circuit-breaker 	500	Emax X1-Tmax T7 withdr.	See kit on page 5/24	Included in Form 2 kit	Included in Form 2 kit	Included in Form 2 kit
	600	Emax E1-E2-E3 fixed				
	600	Emax E1-E2-E3 withdr.				
		Emax E4 fixed				
		Emax E4 withdrawable				

Uprights for switchgear D=900mm

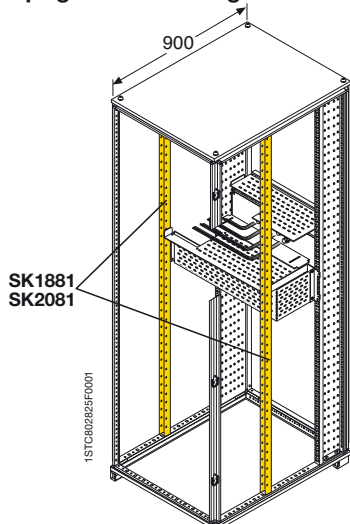

Example of Form 2a segregation

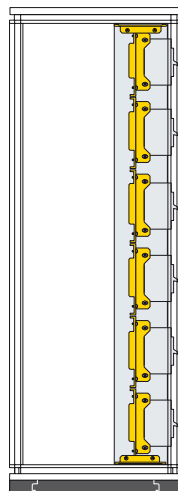

Example of Form 3a segregation

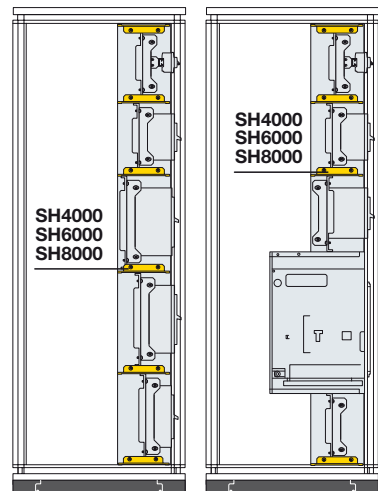

Selection by componentspage 9/51

In-depth technical informationpage 6/10

Overall dimensionspage 8/14

ArTu K segregated structures

Form 2-3-4 segregations for structures D≥500mm

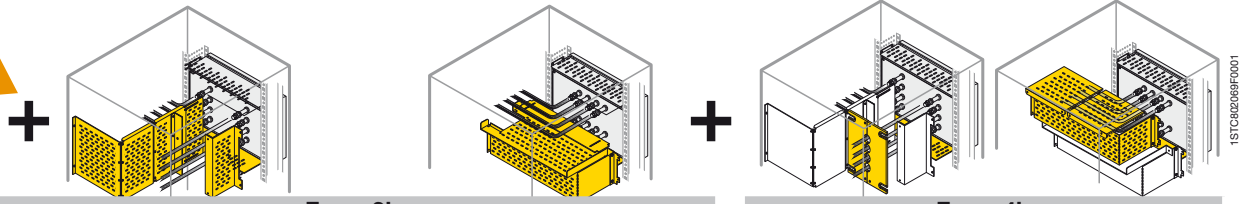

Form 3b			Form 4b						
Horizontal circuit-breaker			Vertical circuit-breaker			Horiz. circ.-breaker	Vertical circuit-breaker		Height kit (mm)
12 DIN mod. W=390mm D=500/700	24 DIN mod. W=600mm D=500/700	24 DIN mod. W=600mm D=900	Structure D=500mm	Structure D=700mm	Structure D=900mm	Structure D=500/700/900mm	Structure D=500mm	Structure D=700mm	
FH3224	FH3220	FH1020				FH4220			200
FH3434	FH3430	FH1030				FH4430			300
FH3544	FH3540	FH1040				FH4540			400
	FH3650	FH1050				FH4650			500
FH3764 ⁽¹⁾	FH3760	FH1060				FH4760			600
	FV4557	FV4557				Included in Form 3b kit			600
	FH3680 ⁽²⁾					4 x FH4220			800
									200
			FV3456	FV3458			FV4456	FV4458	400
			FV3556	FV3558			FV4556	FV4558	500
				FV3668				FV4668	600
				FV3788				FV4788	800
				FH3960				FV4558	500
				FH3960					600
				FH3961					600
					FH3965				
					FH3966				

⁽¹⁾ Only for blind back plate H=600mm.

⁽²⁾ Only for Tmax T6 interlocked in fixed/plug-in/withdrawable/motor operated versions.

Emax segregation Form 3b

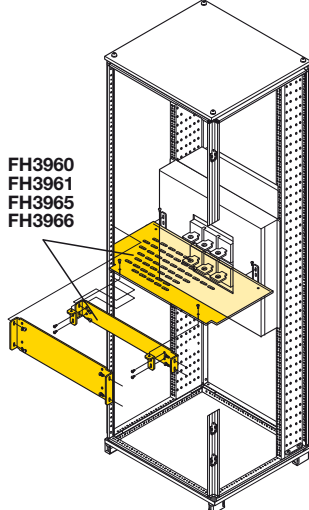

Example of Emax segregation Form 4b

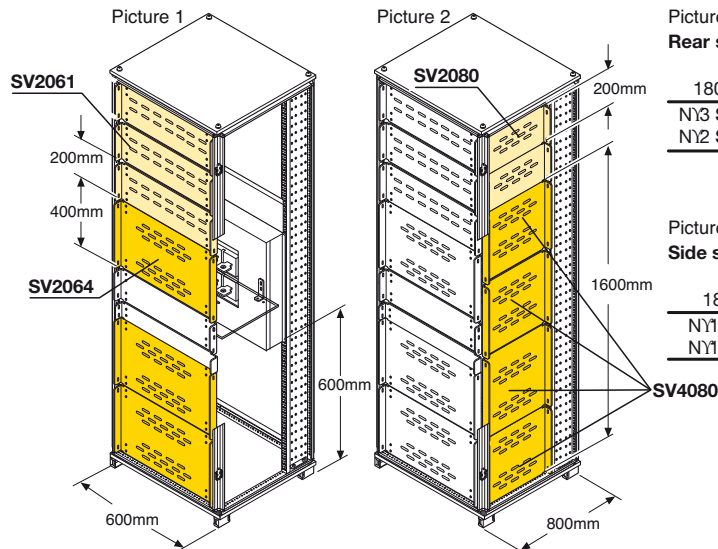

Picture 1
Rear segregation

Structure height		Emax installed
1800mm	2000mm	
N13 SV2064	N13 SV2064	N11
N12 SV2061	N13 SV2061	

Picture 2
Side segregation

Structure height	
1800mm	2000mm
N11 SV4080	N11 SV4080
N11 SV2080	N12 SV2080

ArTu K segregated structures

Busbar segregation

Busbar segregation

The SH2030 and SV2061 versions are reciprocally indispensable for assembly. The SH2030 model and SH4030 model must also be used in combination with shelves SH4000 and SH6000 to make complete horizontal segregations of the busbar system.

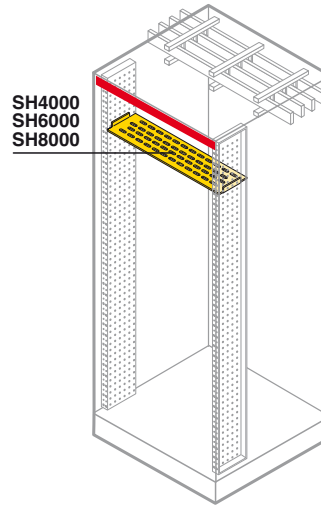

Horizontal Busbars

	12 DIN mod. W=390mm	24 DIN mod. W=600mm	36 DIN mod. W=800mm
Universal horizontal shelf	SH4000 ⁽¹⁾	SH6000 ⁽¹⁾	SH8000 ⁽¹⁾
Horizontal busbar segregation			
Vertical busbar segregation H=200mm			
Vertical busbar segregation H=400mm			
Horizontal segregation for internal cable container W=200mm			
Horizontal segregation for external cable container W=300mm			
Horizontal segregation for structure used as busbar container W=390mm			
Horizontal segregation for structure used as busbar container W=600mm			

Side segregation

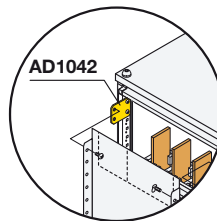

Spacers for AD1042 segregations
Allow simultaneous assembly of the vertical segregations and crosspieces positioned between the functional frame and rear upright (cannot be coupled with the side panel).

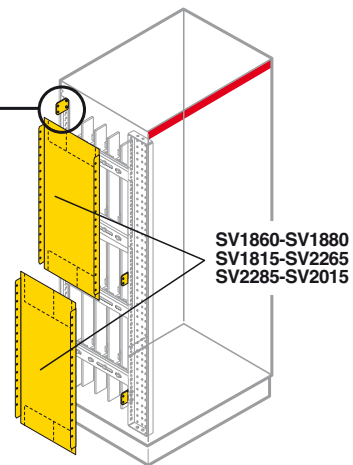

Vertical Busbars

	Structure D=500mm	Structure D=700mm	Structure D=900mm
Vertical segregation for structure H=1800mm	SV1860	SV1880	SV1815
Vertical segregation for structure H=2000mm	SV2265	SV2285	SV2015
Rear segregation for internal cable container			
Segregation/front door for external cable container W=300mm			

ArTu K segregated structures

Busbar segregation

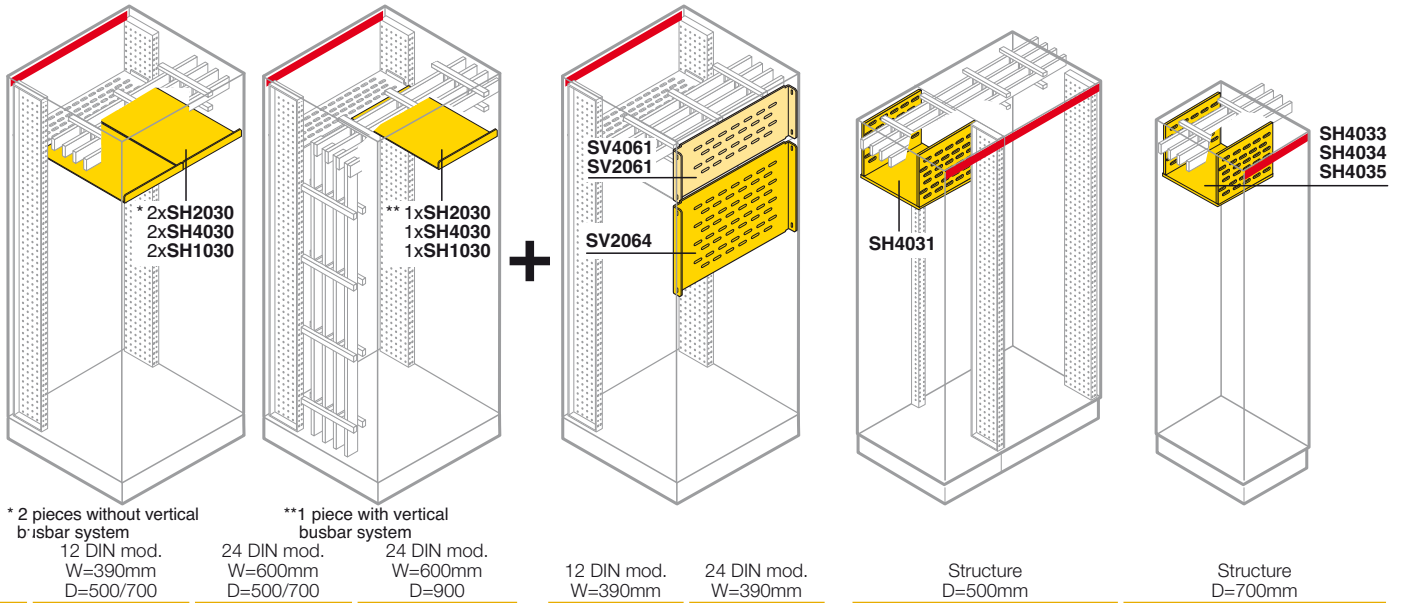

	SH4030	SH2030	SH1030				
				SV4061	SV2061		
					SV2064		
						SH4031	
						SH4033	
						SH4034	
						SH4035	

Rear segregation

Internal cable container

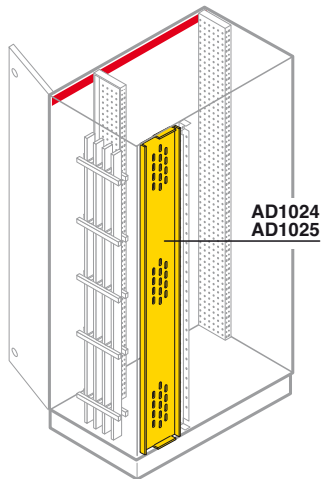

Structure H=1800mm

Structure H=2000mm

	AD1024	AD1025

Front segregation

External cable container

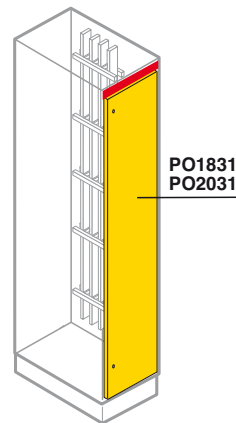

Structure H=1800mm

Structure H=2000mm

PO1831	PO2031

ArTu K Modular structures

Distribution system

Modular dividers

Single-pole

Three-poles

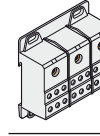
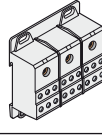
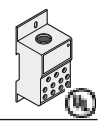
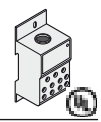
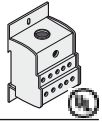
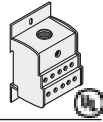

Code		AD1076	AD1080 ⁽¹⁾	AD1007	AD1081 ⁽²⁾	AD1030	AD1031	AD1075	AD1006
In (A)		125	125	160	160	250	400	125	160
Icw (kA)		4.2	4.2	11	11	21	21	11	4.2
Version	poli	1	1	1	1	1	1	3	3
Installation		DIN35/plate	DIN35/plate	DIN35/plate	DIN35/plate	DIN35/plate	DIN35/plate	DIN35/plate	DIN35/plate
Power supply Ø cable (mm²)	min.	10	6	16	10	35	95	10	16
	max	35	35	70	70	120	185	35	70
N°outgoing feeder Ø cable (mm²)	2,5÷10					4	4		
	2,5÷16	10	6	10	6	5	5	6	6
	2,5÷25					2	2		
	2,5÷35								
Dimensions HxWxD (mm)		71x45x42,5	75x25x47	71x45x42,5	92x35x49	96x45x49	96x45x49	80x71,5x42,5	80x71,5x42,5
N° DIN modules		2,5	1,5	2,5	2	3	3	4,5	4,5
Rated service voltage Ue (V)		690	500	690	500	500	500	690	690
Degree of protection	IP	20	20	20	20	20	20	20	20

Four-poles

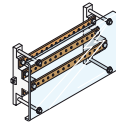
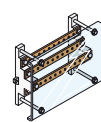
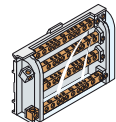
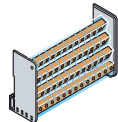
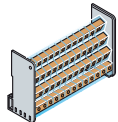
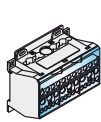

Code		AD1004	AD1028	AD1029	AD1027	AD1034	AD1053
In (A)		125	125	125	160	250	250
Icw (kA)		4.2	4.2	4.2	6.2	15	15
Version	poles	4	4	4	4	4	4
Installation		DIN35/plate	DIN35/plate	DIN35/plate	DIN35	with AD1035 brackets	with AD1035 brackets
Power supply Ø cable (mm²)	min.	6	6	6	10		
	max	35	25 with cable terminal 35 without cable terminal	25 with cable terminal 35 without cable terminal	50		
N°outgoing feeder Ø cable (mm²)	5 holes/phase Ø1÷6		2xØ6÷25 + cable terminal	2xØ6÷25 + cable terminal	8xØ2,5÷16	N°22 holes M5 with 17,5mm pitch per phase	N°32 holes M5 with 17,5mm pitch per phase
	2 holes/phase Ø1,5÷16		2xØ6÷35 no cable terminal	2xØ6÷35 no cable terminal	3xØ6÷35	(threaded busb. 20x5mm)	(threaded busb. 20x5mm)
	6 holes/neutral Ø1,5÷16		9xØ6÷10	2xØ6÷16			
	4 holes/neutral Ø1,5÷6²			9xØ6÷10			
Dimensions HxWxD (mm)		45x75x98	89x93x48	126x93x48	90x160x50	150x600x70	150x800x70
N° DIN modules		5,5	5	7	9	24	36
Rated service voltage Ue (V)		500	690	690	500	500	500
Degree of protection	IP	20	20	20	20		





⁽¹⁾ possibility of putting in parallel with AD1083 connections.

⁽²⁾ possibility of putting in parallel with comb type connection (not supplied).

ArTu K Modular structures

Distribution system

Flexible busbars up to 1250A

Cross-section	In (A)	Code	N° busbar/phase	capacity (A)			WxW (mm)	Section dimensions (mm ²)	Lenght (mm)	Unit weight (kg)
				IP31	IP41	IP65				
	250	BF1602	1	395	323	250	20x3	60	2000	1,42
	400	BF2502	1	498	460	400	20x5	100	2000	2,15
	500	BF4002	1	660	620	500	24x6	144	2000	3
	630	BF4012	1	758	702	630	32x5	160	2000	3,36
	1000	BF6302	1	1203	1140	1000	40x8	320	2000	6,33
	1250	BF8002	1	1515	1390	1250	50x10	500	2000	9,68

1STC8002029F0001

ArTu K Modular Structures

Distribution systems

Busbars with shaped section for applications up to 3200A

Cross-section	In (A)	Code	N° busbar/phase	capacity (A)			I _{cc} max (kA)	Dimensions section (mm ²)		Length (mm)	Weight (kg)
				IP31	IP41	IP65		WxW (mm)			
	400	BA0400	1	630	520	400	35	20x20	200	1730	4
	800	BA0800	1	970	830	800	35	20x20	283	1730	4,4
	1250	BA1250	1	1400	1330	1250	75	20x60	603	1730	9,3
	1600	BA1600	1	1820	1710	1600	75	20x60	703	1730	10
	2000	BA2000	1	2350	2200	2000	100	25x60	1000	1730	14,8
	3200	BA2000	2	3600	3400	3200	100	25x60	2000	1730	29,6

Selection and assembly of busbars with shaped section and busbar holders

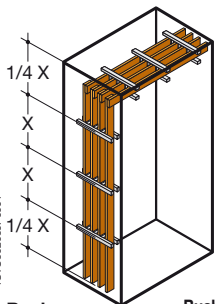

The distance between the first busbar holder and the end of the busbar must not exceed $\frac{1}{4}$ of "X".

N° of busbar holders according to the max. I_{cc}

Busbar code	Busbar capacity	Busbar holder code	N° busbars per phase	N° of busbar holders according to the max. I _{cc}													
				25 kA	X max (mm)	35 kA	X max (mm)	50 kA	X max (mm)	65 kA	X max (mm)	75 kA	X max (mm)	85 kA	X max (mm)	100 kA	X max (mm)
Linear																	
BA0400	400A	PB0803	1	4	550	5	425	-	-	-	-	-	-	-	-	-	
		PB1601 ⁽¹⁾		4	550	4	550	-	-	-	-	-	-	-	-	-	
		PB1603 ⁽¹⁾		4	550	4	550	-	-	-	-	-	-	-	-	-	
BA0800	800A	PB0803	1	4	550	5	425	-	-	-	-	-	-	-	-	-	
		PB1601 ⁽¹⁾		4	550	4	550	-	-	-	-	-	-	-	-		
		PB1603 ⁽¹⁾		4	550	4	550	-	-	-	-	-	-	-	-		
BA1250	1250A	PB1601	1	4	550	4	550	5	425	7	275	9	225	-	-	-	
		PB1603		4	550	4	550	6	350	9	225	-	-	-	-		
BA1600	1600A	PB1601	1	4	550	4	550	5	425	7	275	9	225	-	-	-	
		PB1603		4	550	4	550	6	350	9	225	-	-	-	-		
BA2000	2000A	PB3201	1/2	4	550	4	550	5	425	6	350	7	275	7	275	9	225
Scaled																	
BA0400	400A	PB0802	1	4	550	5	425	-	-	-	-	-	-	-	-	-	
		PB1600 ⁽¹⁾		4	550	4	550	-	-	-	-	-	-	-	-	-	
BA0800	800A	PB0802	1	4	550	5	425	-	-	-	-	-	-	-	-	-	
		PB1600 ⁽¹⁾		4	550	4	550	-	-	-	-	-	-	-	-	-	
BA1250	1250A	PB1600	1	4	550	4	550	5	425	7	275	8	250	-	-	-	
BA1600	1600A	PB1600	1	4	550	4	550	5	425	7	275	8	250	-	-	-	

⁽¹⁾ Can be used with the special **AD1066** adapter.

max X = maximum distance not to be exceeded between two consecutive busbar holders

Using the correct number of busbar holders ensures resistance to electrodynamic forces in the case of a short-circuit.

Assess the maximum distance (max X) which must not be exceeded between two consecutive busbar holders according to the max. I_{cc}.

ArTu K Modular Structures

Distribution systems

Busbar holders and crosspieces

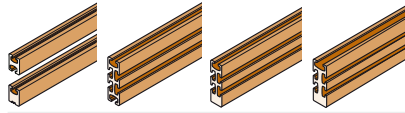

Busbar holder **Busbars with shaped section**

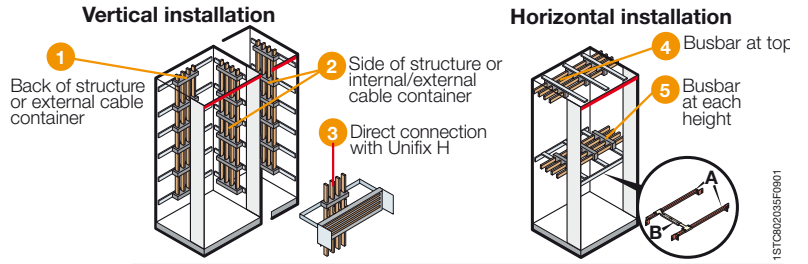

1STCR02025F0901

Crosspieces for fixing to structure

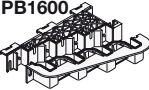
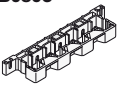
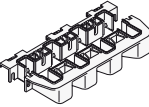
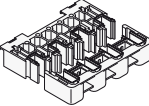
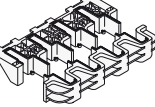
Type	In≤400÷800A	In=1250A	In=1600A	In=3200A	Installation	Switchgear without segregation	Segregated switchgear	Internal cable container	Additional cable container
Scaled up to 800A PB0802 	BA0400 BA0800				1	TV4001 (W=390mm)		TV3000 (D=150mm)	TV3201 (W=300mm)
					2			TV3101 (D=225mm) TV5101 (D=300mm)	TV3101 (D=225mm) TV5101 (D=300mm)
Scaled up to 1600A PB1600 with adap. AD1066 	BA0400 BA0800 AD1066	BA1250	BA1600		1	TV4000 (W=390mm)			TV3201 (W=300mm)
					2	TV8001 (D=700mm) TV1001 (D=900mm)	TV8005 (D=700mm) TV1005 (D=900mm)	TV8101 (D=700mm) TV1101 (D=900mm)	TV6101 (D=500mm) TV8101 (D=700mm) TV1101 (D=900mm)
Linear up to 800A PB0803 	BA0400 BA0800				1	TV4001 (W=390mm) TV6202 (W=600mm) TV8202 (W=800mm)			
					3	TV6203 (W=600mm) TV8203 (W=800mm)		(1)	
Linear up to 1600A PB1601 with adap. AD1066 	BA0400 BA0800 AD1066	BA1250	BA1600		1	TV4000 (W=390mm) TV6201 (W=600mm) TV8201 (W=800mm)	TV6201 (W=600mm) TV8201 (W=800mm)		
					2	TV8001 (D=700mm) TV1001 (D=900mm)	TV8005 (D=700mm) TV1005 (D=900mm)	TV8101 (D=700mm) TV1101 (D=900mm)	TV6101 (D=500mm) TV8101 (D=700mm) TV1101 (D=900mm)
					4	TV8211 (D=700mm) TV1211 (D=900mm)	TV8211 (D=700mm) TV1211 (D=900mm)	TV8211 (D=700mm) TV1211 (D=900mm)	TV8211 (D=700mm) TV1211 (D=900mm)
					A	TV4221 (W=390mm) TV6221 (W=600mm) TV8221 (W=800mm)	TV4221 (W=390mm) TV6221 (W=600mm) TV8221 (W=800mm)		
					5	TV8011 (D=700mm) TV1011 (D=900mm)	TV8011 (D=700mm) TV1011 (D=900mm)	TV8011 (D=700mm) TV1011 (D=900mm)	(1)
					B	TV4000 (W=390mm) TV6201 (W=600mm) TV8201 (W=800mm)	TV4000 (W=390mm) TV6201 (W=600mm) TV8201 (W=800mm)		
Linear up to 1600A PB1603 with adap. AD1066 	BA0400 BA0800 AD1066	BA1250	BA1600		1	TV4000 (W=390mm) TV6201 (W=600mm) TV8201 (W=800mm)	TV4000 (W=390mm) TV6201 (W=600mm) TV8201 (W=800mm)	TV5101 (D=300mm) TV6101 (D=500mm) TV8101 (D=700mm)	TV5101 (D=300mm) TV6101 (D=500mm) TV8101 (D=700mm)
					2	TV6001 (D=500mm) TV8001 (D=700mm) TV1001 (D=900mm)	TV6005 (D=500mm) TV8005 (D=700mm) TV1005 (D=900mm)	TV6101 (D=500mm) TV8101 (D=700mm)	TV6101 (D=500mm) TV8101 (D=700mm)
					4	TV1261 (D=500mm) TV8211 (D=700mm) TV1211 (D=900mm)	TV1261 (D=500mm) TV8211 (D=700mm) TV1211 (D=900mm)	TV5101 (D=300mm) TV1261 (D=500mm) TV8211 (D=700mm) TV1211 (D=900mm)	TV5101 (D=300mm) TV1261 (D=500mm) TV8211 (D=700mm) TV1211 (D=900mm)
					A	TV4221 (W=390mm) TV6221 (W=600mm) TV8221 (W=800mm)	TV4221 (W=390mm) TV6221 (W=600mm) TV8221 (W=800mm)		
					5	TV6011 (D=500mm) TV8011 (D=700mm) TV1011 (D=900mm)	TV6011 (D=500mm) TV8011 (D=700mm) TV1011 (D=900mm)		
					B	TV4000 (W=390mm) TV6201 (W=600mm) TV8201 (W=800mm)	TV4000 (W=390mm) TV6201 (W=600mm) TV8201 (W=800mm)		
Linear up to 3200A PB3201 	BA2000 1/2 busbar per phase				2	TV8001 (D=700mm) TV1001 (D=900mm)	TV8005 (D=700mm) TV1005 (D=900mm)	TV8101 (D=700mm) TV1101 (D=900mm)	TV8101 (D=700mm) TV1101 (D=900mm)
					4	TV8211 (D=700mm)	TV8211 (D=700mm)	TV8211 (D=700mm)	TV8211 (D=700mm)
					5	TV6221 (W=600mm) TV8221 (W=800mm)	TV6221 (W=600mm) TV8221 (W=800mm)		
			A	TV8011 (D=700mm)	TV8011 (D=700mm)				
			B	TV1011 (D=900mm)	TV1011 (D=900mm)				

(1) Only form 2

ArTu K Modular Structures

Distribution systems

Busbar holders and crosspieces

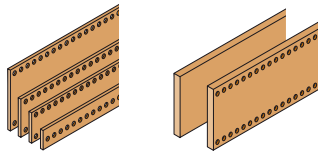

Vertical installation

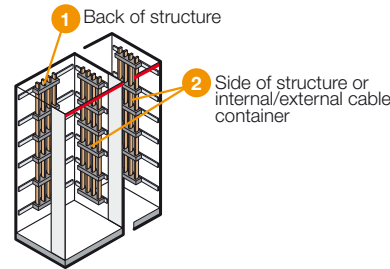

Horizontal installation

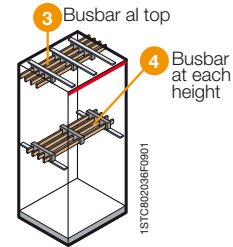

Busbar holder

Flat busbars

Crosspieces for fixing to structure

Type
Linear up to 1250A
BP1250

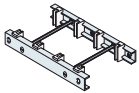

In=400÷1250A

BR4005
BR6305
BR8005
BR1250
1 busbar
per phase

In=1600÷4000A

Installation

Switchgear without
segregation

Segregated
switchgear

Internal cable
container

Additional cable
container

1

TR7005 (W=600mm)
TR8000 (W=800mm)

TR7005 (W=600mm)
TR8000 (W=800mm)

TR6101 (D=500mm)

TR6101 (D=500mm)

2

TR6001 (D=500mm)
TR8001 (D=700mm)
TV1001 (D=900mm)

TR6005 (D=500mm)
TR8005 (D=700mm)
TV1005 (D=900mm)

TR8101 (D=700mm)
TV1101 (D=900mm)

TR8101 (D=700mm)
TV1101 (D=900mm)

3

TV1261 (D=500mm)
TV8211 (D=700mm)
TV1211 (D=900mm)

TV1261 (D=500mm)
TV8211 (D=700mm)
TV1211 (D=900mm)

TV1261 (D=500mm)
TV8211 (D=700mm)
TV1211 (D=900mm)

TV1261 (D=500mm)
TV8211 (D=700mm)
TV1211 (D=900mm)

4

TR6201 (D=500mm)
TR8201 (D=700mm)
TR1201 (D=900mm)

TR6205 (D=500mm)
TR8205 (D=700mm)
TR1205 (D=900mm)

TR6301 (D=500mm)
TR8301 (D=700mm)

TR6301 (D=500mm)
TR8301 (D=700mm)

Linear up to 1600A
BP1600

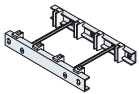

5

In=400÷1250A

BR1600
1 busbar
per phase

In=1600÷4000A

Installation

TR7005 (W=600mm)
TR8000 (W=800mm)

TR7005 (W=600mm)
TR8000 (W=800mm)

TR6101 (D=500mm)

TR6101 (D=500mm)

2

TR6001 (P=500mm)
TR8001 (P=700mm)
TV1001 (P=900mm)

TR6005 (D=500mm)
TR8005 (D=700mm)
TV1005 (D=900mm)

TR8101 (D=700mm)
TV1101 (D=900mm)

TR8101 (D=700mm)
TV1101 (D=900mm)

3

TV1261 (P=500mm)
TV8211 (P=700mm)
TV1211 (P=900mm)

TV1261 (D=500mm)
TV8211 (D=700mm)
TV1211 (D=900mm)

TV1261 (D=500mm)
TV8211 (D=700mm)
TV1211 (D=900mm)

TV1261 (D=500mm)
TV8211 (D=700mm)
TV1211 (D=900mm)

4

TR6201 (P=500mm)
TR8201 (P=700mm)
TR1201 (P=900mm)

TR6205 (D=500mm)
TR8205 (D=700mm)
TR1205 (D=900mm)

TR6301 (D=500mm)
TR8301 (D=700mm)

TR6301 (D=500mm)
TR8301 (D=700mm)

Linear up to 2500A
BP2500

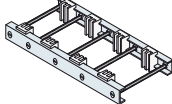

In=400÷1250A

BR1600
2 busbars
per phase

In=1600÷4000A

Installation

TR7005 (W=600mm)
TR8000 (W=800mm)

TR7005 (W=600mm)
TR8000 (W=800mm)

TR8101 (D=700mm)

TR8101 (D=700mm)

2

TR8001 (D=700mm)
TV1001 (D=900mm)

TR8005 (D=700mm)
TV1005 (P=900mm)

TV1101 (D=900mm)

TV1101 (D=900mm)

3

TV8211 (D=700mm)
TV1211 (D=900mm)

TV8211 (D=700mm)
TV1211 (D=900mm)

TV8211 (D=700mm)
TV1211 (D=900mm)

TV8211 (D=700mm)
TV1211 (D=900mm)

4

TR8201 (D=700mm)
TR1201 (D=900mm)

TR8205 (D=700mm)
TR1205 (D=900mm)

TR8301 (D=700mm)

TR8301 (D=700mm)

Linear up to 3200A
BP3200

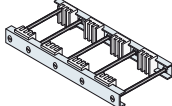

In=400÷1250A

BR1600
3 busbars
per phase

In=1600÷4000A

Installation

TR7005 (W=600mm)
TR8000 (W=800mm)

TR7005 (W=600mm)
TR8000 (W=800mm)

TR8101 (D=700mm)

TR8101 (D=700mm)

2

TR8001 (D=700mm)
TV1001 (D=900mm)

TR8005 (D=700mm)
TV1005 (D=900mm)

TV1101 (D=900mm)

TV1101 (D=900mm)

3

TV8211 (D=700mm)
TV1211 (D=900mm)

TV8211 (D=700mm)
TV1211 (D=900mm)

TV8211 (D=700mm)
TV1211 (D=900mm)

TV8211 (D=700mm)
TV1211 (D=900mm)

4

TR8201 (D=700mm)
TR1201 (D=900mm)

TR8205 (D=700mm)
TR1205 (D=900mm)

TR8301 (D=700mm)

TR8301 (D=700mm)

Linear up to 4000A
BP3200

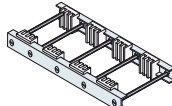

In=400÷1250A

BR2000
3 busbars
per phase

In=1600÷4000A

Installation

TR8000 (W=800mm)

TR8000 (W=800mm)

2

TV1001 (D=900mm)

TV1005 (D=900mm)

TV1101 (D=900mm)

TV1101 (D=900mm)

3

TV1311 (D=900mm)

TV1311 (D=900mm)

TV1311 (D=900mm)

TV1311 (D=900mm)

4

TR1201 (D=900mm)

TR1205 (D=900mm)

BR2000 not drilled

ArTu K Modular Structures

Distribution systems

Flat busbars for distribution up to 4000A

Cross-section	In (A)	Code	N° busbar/phase	capacity (A)			Icw max (kA)	WxW (mm)	Length (mm)	Weight (kg)
				IP31	IP41	IP65				
	400	BR4005	1	530	490	400	35	32x5	1750	2,1
	630	BR6305	1	772	695	630	50	50x5	1750	3,4
	800	BR8005	1	951	863	800	50	63x5	1750	4,4
	1250	BR1250	1	1431	1347	1250	50	100x5	1750	7,25
	1600	BR1600	1	1836	1710	1600	105	100x10	1750	14,5
	2000	BR2000	1	2250	2110	2000	105	120x10	1750	18,7
	2500	BR1600	2	3056	2700	2500	105	100x10	1750	29
	3000	BR2000	2	3500	3200	3000	105	120x10	1750	37,4
	3200	BR1600	3	4018	3600	3200	105	100x10	1750	43,5
	4000	BR2000	3	4460	4250	4080	105	120X10	1750	56,1

Selection and assembly of flat busbars and busbar holders

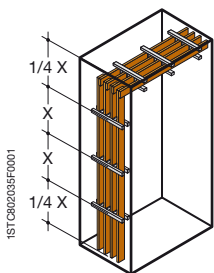

The distance between the first busbar holder and the end of the busbar must not exceed $\frac{1}{4}$ of "X".

Using the correct number of busbar holders ensures resistance to electrodynamic forces in the case of a short-circuit.

Assess the maximum distance (max X) not to be exceeded between two consecutive busbar holders according to the max. I_{cc} .

N° of busbar holders according to the max. I_{cc}

Busbar code	capacity	Busbar holder code	N° busbars/type per phase	25 kA		35 kA		50 kA		75 kA		105 kA	
				X max (mm)	X max (mm)	X max (mm)	X max (mm)	X max (mm)	X max (mm)				
BR4005	400A	BP1250	1	7	300	9	225	-	-	-	-	-	-
BR6305	630A	BP1250	1	6	375	7	275	9	225	-	-	-	-
BR8005	800A	BP1250	1	5	425	7	300	9	225	-	-	-	-
BR1250	1250A	BP1250	1	4	500	6	375	8	250	-	-	-	-
BR1600	1600A	BP1600	1	3	1000	3	1000	4	600	6	375	9	225
BR2000	2000A	BP1600	1	3	1000	3	1000	4	600	6	375	9	225
BR1600	2500A	BP2500	2 x BR 1600	3	1000	3	1000	3	900	5	400	9	225
BR2000	3000A	BP2500	2 x BR 2000	3	1000	3	1000	3	900	5	400	9	225
BR1600	3200A	BP3200	3 x BR 1600	3	1000	3	1000	3	800	5	400	9	225
BR2000	4000A	BP3200	3 x BR 2000	3	1000	3	1000	3	800	5	400	9	225

max X = maximum distance not to be exceeded between two consecutive busbar holders

Flat drilled and threaded busbars for earthing connection

Cross-section	Code	Threading	Pitch	WxW (mm)	Length (mm)	AxB (mm)
	EV1119	6 MA	20	20x5	2000	
	EV1120	6 MA	20	25x5	2000	
	EV1121	6MA	25	50x5	2000	
	EV1122	6MA				34x30
	EV1123	8MA				34x30
	EV1124	6MA				40x50
	EV1125	8MA				40x50

Selection by componentspage 9/51

In-depth technical informationpage 6/10

Overall dimensionspage 8/14

ArTu K Modular Structures

Distribution systems

Technical characteristics

Technical characteristics	Unifix H	Unifix L
Rated service voltage (U_n)	690V ca	400V ca
Rated insulation voltage (U)	1000V ca	500V ca
Rated impulse withstand voltage (U_{imp})	8kV	6kV
Rated frequency	50/60Hz	50/60Hz
Rated current (I_n)	central power supply 400A lateral power supply 320A	100A 80A
Rated short-time withstand current (I_{cw})	25kA	
Maximum peak current (I_{pk})	52,5kA-400V	
Maximum installable circuit-breaker size	250A	100A
Conditioned short-circuit current (I_{cc})	Tmax T1 36kA-400V Tmax T2 N, S ⁽¹⁾ 50kA-400V Tmax T3 50kA-400V XT1 50kA-400V XT3 50kA-400V	
With circuit-breaker	S200 S200 H S200 P	6kA-400V 10kA-400V 25kA-400V
Degree of protection	IP20 with accessory	IP20
Characteristics of the insulating material	Self-extinguishing thermoplastic V1 (UL94)	Self-extinguishing thermoplastic V1 (UL94)
Characteristics of the conductor material	Electrolytic copper	Electrolytic copper
Width (N° modules/mm)	24/600 - 36/800	12/400 - 24/600 - 36/800

Installation of Unifix system

Frame for Tmax	300x600mm (hxl) 300x800mm (hxl)	ED2183 ED2191 AD1061 TV6202 ⁽²⁾ TV6203 TV8203	
Fixing bracket H=300mm			
Crosspiece for direct connection to the rear busbars with shaped section with PB0803	W=600mm W=800mm		
Busbar 2P	12 mod. 18 mod. 24 mod. 36 mod.		ED2993 ED3009 ED3017 ED3025 ED2944 ED2951 ED2969 ED2977 GD4002 GD6002 GD8002
Busbar 4P	12 mod. 18 mod. 24 mod. 36 mod.		
Fixing support	12 mod. 24 mod. 36 mod.		

⁽¹⁾ Select circuit-breakers in version with front terminals for copper cables.

⁽²⁾ ArTu D=150mm.

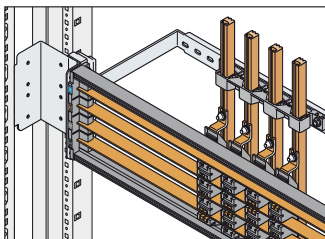

Direct connection with the 400/800A system of busbars with shaped section.

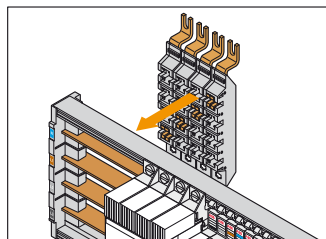

Feeder module for 400A frame (L1-L2-L3-N).

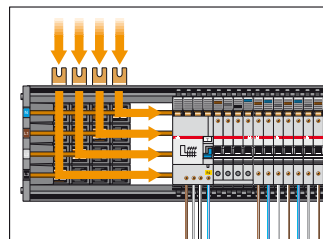

Direct power supply of the bases by means of feeder module ED2209.

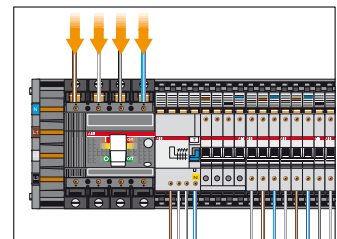

Power supply by means of general row circuit-breaker.

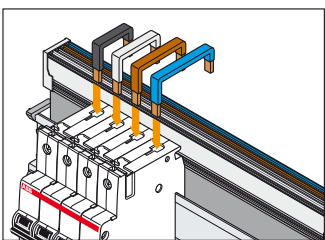

Connections (L1-L2-L3-N) for System Pro M modular apparatus.

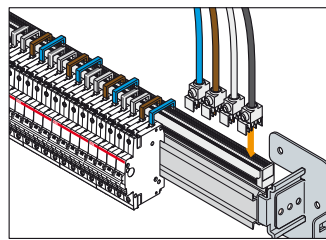

Power supply of the busbar with 100A feeder module without cable. Terminal capacity 35mm².

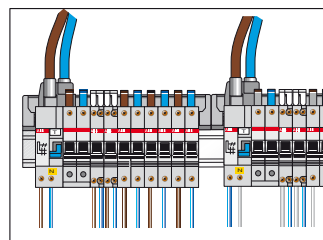

Direct power supply of the busbars by means of feeder module.

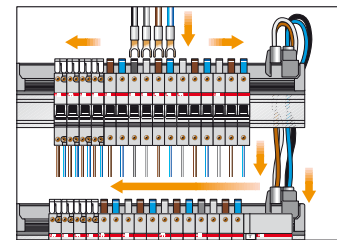

Power supply by means of modules and cables in parallel.

ArTu K Modular Structures

Distribution systems

Table for selecting connections according to the circuit-breaker

Circuit-breaker series	Unifix H	Unifix L	
S941 - S951 - S971 DS941 - DS951 - DS971	(top power supply) ED2654 L1/N 40A ED2662 L2/N 40A ED2670 L3/N 40A	ED3272 L1/N 40A ED3280 L2/N 40A ED3298 L3/N 40A	
S200 - DS200 F200 up to 63A (Unifix L)	(top power supply) ED2531 L1 63A ED2549 L2 63A ED2556 L3 63A ED2564 N 63A ED2845 False pole module	(bottom power supply) ED2572 L1 63A ED2590 L2 63A ED2598 L3 63A ED2606 N 63A	ED3033 L1 100A ED3041 L2 100A ED3058 L3 100A ED3066 N 100A
S800	(top power supply) ED2557 L1 ≤32A ED2558 L2 ≤32A ED2559 L3 ≤32A ED2560 N ≤32A ED2551 L1 125A ED2552 L2 125A ED2553 L3 125A ED2554 N 125A ED2550 False pole module		
F660 - F670 - S280 (80-100A) E200 up to 100A - RS370 - F200 80/100A (Unifix H)	(top power supply) ED2720 L1 100A ED2738 L2 100A ED2746 L3 100A ED2753 N 100A	ED3132 L1/L2/L3/N power sup. - 350mm ED0026 L1/L2/L3/N pow. sup. - 1500mm ED0025 L1/L2/L3/N pow. sup. - 2500mm	
MDRC - Various apparatus	(top power supply) ED2894 L1/N 16A ED2902 L1/L2 16A	(bottom power supply) ED2910 L1/N 16A ED2928 L1/L2 16A	ED3108 Power sup. 2 cables L1/N 16A ED3116 Power sup. 3 cables L1/L2/L3 16A ED3124 Power sup. 4 cables L1/L2/L3/N 16A ED3355 Power sup. 2 cables L1/N 40A ED3363 Power sup. 3 cables L1/L2/L3 40A ED3371 Power sup. 4 cables L1/L2/L3/N 71A
Tmax T1 Tmax XT1	(top/bottom power supply) ED2217 L1 Top/L2 Bottom ED2225 L2 Top/L1 Bottom ED2233 L3 Top/N Bottom ED2241 N Top/L3 Bottom ED2373 False pole module ED2381 False pole module		
Tmax T2 Tmax XT2	(top/bottom power supply) ED2258 L1 Top/L2 Bottom ED2266 L2 Top/L1 Bottom ED2274 L3 Top/N Bottom ED2282 N Top/L3 Bottom ED2373 False pole module ED2399 False pole module		
Tmax T3 - XT3	(top power supply) ED2290 L1 ED2308 L2 ED2316 L3 ED2324 N ED2373 False pole module	(bottom power supply) ED2332 L1 ED2340 L2 ED2357 L3 ED2365 N	

For the DDA locks, order the false module **ED2845** codes according to the size of the residual current lock.

For kit Isomax S1÷S7, please see page 9/66.

Selection by componentspage 9/51

In-depth technical informationpage 6/10

Overall dimensionspage 8/14

ArTu K Modular Structures

Examples of configurations

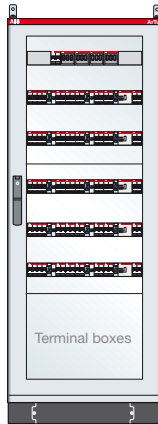

ArTu K Series dim. 1600x500x150 (1831x748x287) mm (external hxwx d) IP65 with modular panels

Code	Description	Q.ty
AD1808	N°2 wall fixing brackets, K	1
GD6002	DIN rail Kit without segreg.24 mod. w=600mm, K	6
LF1626	N°2 side panels 1600x250mm (hxd) K	1
PC4600	Blind panel 400x600mm (hwx) M, K	1
PM6672	Panel 72 mod. 600x600mm (hwx) M, K	2
PV1661	Glass door 1600x600mm (hwx) K	1
RF1660	Rear panel 1600x600mm (hwx) K	1
SK1600	N°4 ArTu K uprights h=1600mm	1
SK1604	N°2 reduced funct. frames h=1600mm K d=250mm	1
SK6025	ArTu K Base/Top/Base strip 600x250mm (wxd)	1

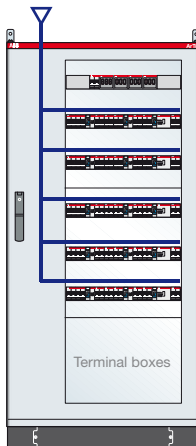

ArTu K Series dim. 1600x800x150 (1831x948x287) mm (external hxwx d) IP65 with modular panels

Code	Description	Q.ty
AD1808	N°2 wall fixing brackets, K	1
GD6002	DIN rail Kit without segreg.24 mod. w=600mm, K	6
LF1626	N°2 side panels 1600x250mm (hxd) K	1
PC4600	Blind panel 400x600mm (hwx) M, K	1
PM6672	Panel 72 mod. 600x600mm (hwx) M, K	2
PV1681	Glass door 1600x600mm (hwx) K	1
RF1680	Rear panel 1600x600mm (hwx) K	1
SK1600	N°4 ArTu K uprights h=1600mm	1
SK8025	ArTu K Base/Top/Base strip 800x250mm (wxd)	1
VC1624	Int. reduced cable cont.1600x250mm (hxd) K	1

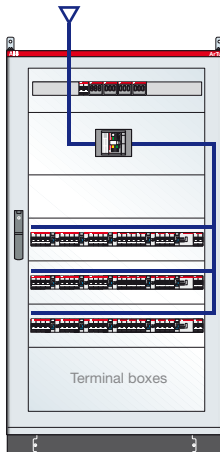

ArTu K Series dim. 1600x800x150 (1831x948x287) mm (external hxwx d) IP65 with plate for Tmax T5 and modular panels

Code	Description	Q.ty
AD1808	N°2 wall fixing brackets, K	1
GD6002	DIN rail Kit without segreg.24 mod. w=600mm, K	6
KL5114	Hor. fixed T5 Kit 300x800mm(hwx) M,K	1
LF1626	N°2 side panels 1600x250mm (hxd) K	1
PC2800	Blind panel 200x800mm (hwx) M, K	1
PC3800	Blind panel 300x800mm (hwx) M, K	1
PM2836	Panel 36 mod. 200x800mm (hwx) M, K	4
PV1682	Glass door 36 mod. 1600x800mm (hwx) K	1
RF1680	Rear panel 1600x800mm (hwx) K	1
SK1600	N°4 ArTu K uprights h=1600mm	1
SK1604	N°2 reduced funct. frames h=1600mm K d=250mm	1
SK8025	ArTu K Base/Top/Base strip 800x250mm (wxd)	1

ArTu K Modular Structures

Examples of configurations

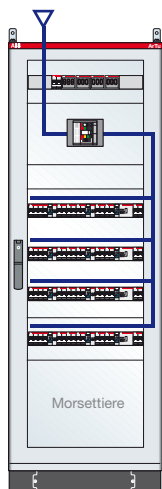

ArTu K Series dim. 1800x600x150 (2031x748x287) mm (external hwxwd) IP65 with plate for Tmax T5 and modular panels, complete with 400A busbars vertically on back of structure - l_{cw} max 35kA

Code	Description	Q.ty
AD1808	N°2 wall fixing brackets, K	1
BA0400	Busbar In=400A	4
GD6002	DIN rail Kit without segreg. 24 mod. w=600mm, K	5
KT5112	Hor. fixed T5 Kit 300x600mm(hxw) M,K	1
LF1826	N°2 side panels 1800x250mm (hxd) K	1
PB0803	Linear busbar holder In=800A (35kA)	5
PC1600	Blind panel 100x600mm (hxw) M, K	1
PC4600	Blind panel 400x600mm (hxw) M, K	1
PM2624	Panel 24 mod. 200x600mm (hxw) M, K	2
PM6672	Panel 72 mod. 600x600mm (hxw) M, K	1
PV1861	Glass door 1800x600mm (hxw) K	1
RF1860	Rear panel 1800x600mm (hxw) K	1
SK1800	N°4 ArTu K uprights h=1800mm	1
SK1804	N°2 reduced funct. frames h=1800mm K d=250mm	1
SK6025	ArTu K Base/Top/Base strip 600x250mm (wxd)	1
TV6202	N°2 rear of struct. crosspieces w=600xPB0803	3

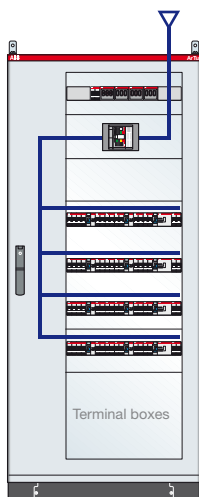

ArTu K Series dim. 1800x800x150 (2031x948x287) mm (external hwxwd) IP65 with plate for Tmax T3 and modular panels, complete with 800A busbars vertically on back of internal cable cont. - l_{cw} max 35kA

Code	Description	Q.ty
AD1808	Rear panel 1800x800mm (hxw) K	1
BA0800	Busbar In=800A	4
GD6002	DIN rail Kit without segreg. 24 mod. w=600mm, K	5
KT3112	T3 3/4P horiz. fixed without segreg. Kit M, K250	1
LF1826	N°2 pann. later. 1800x150mm (hxp) K	1
PB0802	Scaled busbar holder In=800A (35 kA)	5
PC2600	Blind panel 200x600mm (hxw) M, K	1
PC4600	Blind panel 400x600mm (hxw) M, K	1
PM2624	Panel 24 mod. 200x600mm (hxw) M, K	2
PM6672	Panel 72 mod. 600x600mm (hxw) M, K	1
PV1881	Glass door 1800x800mm (hxw) K	1
RF1880	Rear panel 1800x800mm (hxw) K	1
SK1800	N°4 ArTu K uprights h=1800mm	1
SK8025	ArTu K Base/Top/Base strip 800x250mm (wxd)	1
TV3000	N°2 int. cable cont. cross. w=200mm x K d=250mm	3
VC1824	Int. reduced cable cont. 1800x250mm (hxd) K	1

ArTu K Series dim. 1800x800x150 (2031x948x287) mm (external hwxwd) IP65 with plate for Tmax XT3 and modular panels, complete with 800A busbars vertically on back of internal cable cont. - l_{cw} max 35kA

Code	Description	Q.ty
AD1808	Rear panel 1800x800mm (hxw) K	1
BA0800	Busbar In=800A	4
GD6002	DIN rail Kit without segreg. 24 mod. w=600mm, K	5
KX3612	XT3 3/4P horiz. fixed without segreg. Kit M, K250	1
LF1826	N°2 pann. later. 1800x150mm (hxp) K	1
PB0802	Scaled busbar holder In=800A (35 kA)	5
PC2600	Blind panel 200x600mm (hxw) M, K	1
PC4600	Blind panel 400x600mm (hxw) M, K	1
PM2624	Panel 24 mod. 200x600mm (hxw) M, K	2
PM6672	Panel 72 mod. 600x600mm (hxw) M, K	1
PV1881	Glass door 1800x800mm (hxw) K	1
RF1880	Rear panel 1800x800mm (hxw) K	1
SK1800	N°4 ArTu K uprights h=1800mm	1
SK8025	ArTu K Base/Top/Base strip 800x250mm (wxd)	1
TV3000	N°2 int. cable cont. cross. w=200mm x K d=250mm	3
VC1824	Int. reduced cable cont. 1800x250mm (hxd) K	1

ArTu K Modular Structures

Examples of configurations

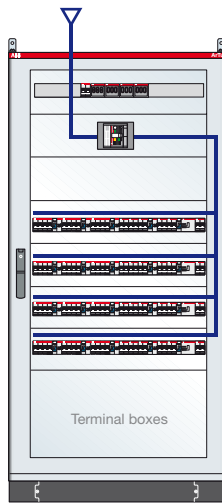

**ArTu K Series dim. 1800x800x150 (2031x948x287) mm (external hxwxd)
IP65 with plate for Tmax T3 and modular panels, complete with 800A
busbars vertically on back of internal cable cont. - l_{cw} max 35kA**

Code	Description	Q.ty
AD1808	Rear panel 1800x800mm (hxw) K	1
BA0800	Busbar In=800A	4
GD8002	DIN rail Kit without segreg.36 mod. w=800mm, K	5
KL3113	T3 3/4P horiz. fixed without segreg. Kit w=800mm M, K250	1
LF1826	N°2 side panels 1800x250mm (hxd) K	1
PB0803	Linear busbar holder In=800A (35kA)	5
PC2800	Blind panel 200x800mm (hxw) M, K	1
PC4800	Blind panel 400x800mm (hxw) M, K	1
PM2836	Panel 36 mod. 200x800mm (hxw) M, K	5
PV1882	Glass door 36 mod. 1800x800mm (hxw) K	1
RF1880	Rear panel 1800x800mm (hxw) K	1
SK1800	N°4 ArTu K uprights h=1800mm	1
SK1804	N°2 reduced funct. frames h=1800mm K d=250mm	1
SK8025	ArTu K Base/Top/Base strip 800x250mm (wxd)	1
TV8202	N°2 rear of struct. crosspieces w=800xPB0803	3

**ArTu K Series dim. 1800x800x150 (2031x948x287) mm (external hxwxd)
IP65 with plate for Tmax XT3 and modular panels, complete with 800A
busbars vertically on back of internal cable cont. - l_{cw} max 35kA**

Code	Description	Q.ty
AD1808	Rear panel 1800x800mm (hxw) K	1
BA0800	Busbar In=800A	4
GD8002	DIN rail Kit without segreg.36 mod. w=800mm, K	5
KL3613	XT3 3/4P horiz. fixed without segreg. Kit w=800mm M, K250	1
LF1826	N°2 side panels 1800x250mm (hxd) K	1
PB0803	Linear busbar holder In=800A (35kA)	5
PC2800	Blind panel 200x800mm (hxw) M, K	1
PC4800	Blind panel 400x800mm (hxw) M, K	1
PM2836	Panel 36 mod. 200x800mm (hxw) M, K	5
PV1882	Glass door 36 mod. 1800x800mm (hxw) K	1
RF1880	Rear panel 1800x800mm (hxw) K	1
SK1800	N°4 ArTu K uprights h=1800mm	1
SK1804	N°2 reduced funct. frames h=1800mm K d=250mm	1
SK8025	ArTu K Base/Top/Base strip 800x250mm (wxd)	1
TV8202	N°2 rear of struct. crosspieces w=800xPB0803	3

ArTu K Modular Structures

Examples of configurations

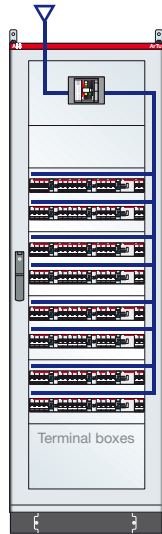

ArTu K Series dim. 2000x600x150 (2131x748x287) mm (external hwxwd) IP65 with plate for Tmax T5-630A and modular panels, complete with 400A busbars vertically on back of structure - Icw max 35kA

Code	Description	Q.ty
AD1808	N°2 wall fixing brackets, K	1
BA0400	Busbar In=400A	4
GD6008	DIN rail Kit int. 150mm w=600mm M floor-mount. K	4
KT5112	Hor. fixed T5 Kit 300x600mm(hxw) M,K	1
LF2026	N°2 side panels 2000x250mm (hxd) K	1
PB0803	Linear busbar holder In=800A (35kA)	5
PC2600	Blind panel 200x600mm (hxw) M, K	1
PC3600	Blind panel 300x600mm (hxw) M, K	1
PM3648	Panel 48 mod. 300x600mm (hxw) M, K	4
PV2061	Glass door 2000x600mm (hxw) K	1
RF2060	Rear panel 2000x600mm (hxw) K	1
SK2000	N°4 ArTu K uprights h=2000mm	1
SK2004	N°2 reduced funct. frames h=2000mm K d=250mm	1
SK6025	ArTu K Base/Top/Base strip 600x250mm (wxd)	1
TV6202	N°2 rear of struct. crosspieces w=600xPB0803	3

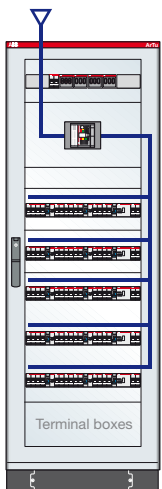

ArTu K Series dim. 1800x600x350 (2031x748x225) mm (external hwxwd) IP65 with plate for Isomax S5 and modular panels, complete with 800A busbars vertically on back of structure - Icw max 35kA

Code	Description	Q.ty
AD1066	N°4 busbar adapters In=800A with busbar holders up to 1600A	3
BA0800	Busbar In=800A	4
GD6002	DIN rail Kit without segreg.24 mod. w=600mm, K	6
KT5112	Hor. fixed T5 Kit+accessories 300x600mm (hxw) K	1
LF1840	N°2 side panels 1800x350mm (hxd) K	1
PB1601	Linear busbar holder In=1600A (75 kA)	3
PC1600	Blind panel 100x600mm (hxw) M, K	1
PC2600	Blind panel 200x600mm (hxw) M, K	1
PM2624	Panel 24 mod. 200x600mm (hxw) M, K	3
PM6672	Panel 72 mod. 600x600mm (hxw) M, K	1
PV1861	Glass door 1800x600mm (hxw) K	1
RF1860	Rear panel 1800x600mm (hxw) K	1
SK1800	N°4 ArTu K uprights h=1800mm	1
SK1804	N°2 funct. frames h=1800mm open K	1
SK6040	ArTu K Base/Top/Base strip 600x350mm (wxd)	1
TV6201	N°2 structure crosspieces w=600mm	2

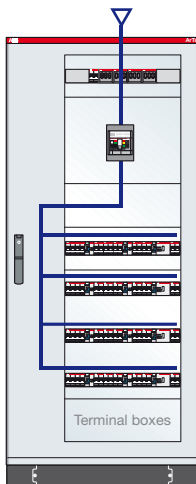

ArTu K Series dim. 1800x800x225 (2031x948x362) mm (external hwxwd) IP65 with plate for Tmax T5 and modular panels, complete with 800A busbars vertically on side of int. cable container - Icw max 35kA

Code	Description	Q.ty
BA0800	Busbar In=800A	4
GD6002	DIN rail Kit without segreg.24 mod. w=600mm, K	5
KT5102	Kit T5 3/4P vertic. fisso+mod diff. non segreg. K 500x600mm (hxl)	1
LF1840	N°2 side panels 1800x350mm (hxd) K	1
PB0802	Scaled busbar holder In=800A (35 kA)	5
PC1600	Blind panel 100x600mm (hxw) M, K	1
PC2600	Blind panel 200x600mm (hxw) M, K	1
PM2624	Panel 24 mod. 200x600mm (hxw) M, K	2
PM6672	Panel 72 mod. 600x600mm (hxw) M, K	1
PV1881	Glass door 1800x800mm (hxw) K	1
RF1880	Rear panel 1800x800mm (hxw) K	1
SK1800	N°4 ArTu K uprights h=1800mm	1
SK8040	ArTu K Base/Top/Base strip 800x350mm (wxd)	1
TV3101	N°2 int./ext. cable cont. crosspieces d=350mm	3
VC1824	Int. reduced cable cont.1800x200mm (hxw) K	1

ArTu K Modular Structures

Examples of configurations

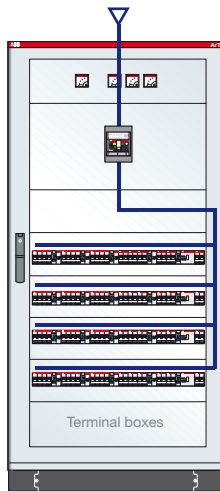

ArTu K Series dim. 1800x800x225 (2031x948x362)mm (external hxwx d) IP65 with plate for Tmax T5 and modular panels

Code	Description	Q.ty
GD8002	DIN rail kit not segregated 36 mod. w=800mm, K	4
KL5102	Kit for T5 3/4 poles fixed + RC mod. not segregated K 500x600mm (hwxw)	1
LF1840	N°2 side panels 1800x350mm (hxd) K	1
PC1800	Blind panel 100x800mm (hwxw) M, K	1
PC2800	Blind Panels 200x800mm (hwxw) M, K	1
PM2836	36 mod. panels 200x800mm (hwxw) M, K	4
PS4968	Panels for 4 instruments 96x96 200x800mm (hwxw)M, K	1
PV1882	Glass door 36 mod. 1800x800mm (hwxw) K	1
RF1880	Rear panel 1800x800mm (hwxw) K	1
SK1800	N°4 uprights ArTu K h=1800mm	1
SK1804	N°2 functional frames h=1800mm aperto K	1
SK8040	Base/Top/Base strip ArTu K 800x350mm (wx d)	1

ArTu K Modular Structures

Examples of configurations

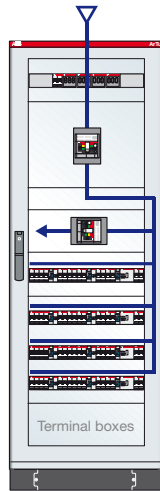

ArTu K Series dim. 2000x600x300 (2231x748x437)mm (external hxwxd) IP65 with plate for Tmax T5, T2 and modular panels

Code	Description	Q.ty
GD6002	DIN rail kit not segregated 24 mod. w=600mm, K	5
KT5102	Kit for T5 3/4 poles fixed + RC mod. not segregated K 500x600mm (hxw)	1
KT2117	Kit for T2 3/4 p. horiz. fixed 200x600mm (hxlw)	1
LF2050	N°2 side panels 200x300mm (hxd) K	1
PC3600	Blind panel 200x600mm (hxw) M, K	1
PM2624	24 mod. Panel 200x600mm (hxw) M, K	2
PM6672	72 mod. Panel 600x600mm (hxw) M, K	1
PV2061	Glass door 2000x600mm (hxw) K	1
RF2060	Rear panel. 2000x600mm (hxw) K	1
SK2000	N°4 uprights ArTu K h=2000mm	1
SK2004	N°2 functional frames h=2000mm open K	1
SK6050	Base/Top/Base strip ArTu K 600x300mm (wxd)	1

ArTu K Series dim. 2000x600x300 (2231x748x437)mm (external hxwxd) IP65 with plate for Tmax T5, XT2 and modular panels

Code	Description	Q.ty
GD6002	DIN rail kit not segregated 24 mod. w=600mm, K	5
KT5102	Kit for T5 3/4 poles fixed + RC mod. not segregated K 500x600mm (hxw)	1
KX2619	Kit for XT2 3/4 p. horiz. fixed 200x600mm (hxlw)	1
LF2050	N°2 side panels 200x300mm (hxd) K	1
PC3600	Blind panel 200x600mm (hxw) M, K	1
PM2624	24 mod. Panel 200x600mm (hxw) M, K	2
PM6672	72 mod. Panel 600x600mm (hxw) M, K	1
PV2061	Glass door 2000x600mm (hxw) K	1
RF2060	Rear panel. 2000x600mm (hxw) K	1
SK2000	N°4 uprights ArTu K h=2000mm	1
SK2004	N°2 functional frames h=2000mm open K	1
SK6050	Base/Top/Base strip ArTu K 600x300mm (wxd)	1

ArTu K Modular Structures

Examples of configurations

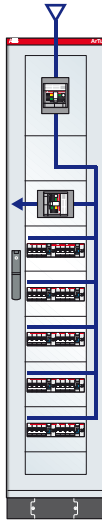

ArTu K Series dim. 2000x390x225 (2231x538x362) mm (external hxd) IP65 with plate for Tmax T5, T2 and modular panels, complete with 800A busbars vertically on back of structure - Icw max 35kA

Code	Description	Q.ty
AD1066	N°4 busbar adapters In=800A with bus. hold. up to 1600A	4
BA0800	Busbar In=800A	4
GD4002	DIN rail Kit without segreg.12 mod. w=400mm, K	5
KT2411	T2 3/4P horiz. fixed without segreg. Kit, K	1
KT5412	T5 vert. fixed Kit 400x400mm (hxd)	1
LF2040	N°2 side panels 2000x350mm (hxd) K	1
PB1601	Linear busbar holder In=1600A (75 kA)	4
PC2400	Blind panel 200x400mm (hxd) K	2
PM2424	Panel 12 mod. 200x400mm (hxd) K	5
PV2041	Glass door 2000x400mm (hxd) K	1
RF2040	Rear panel 2000x400mm (hxd) K	1
SK2000	N°4 ArTu K uprights h=2000mm	1
SK2003	N°2 funct. frames h=2000mm open K	1
SK4040	ArTu K Base/Top/Base strip 400x350mm (wxd)	1
TV4000	N°2 rear crosspieces w=400mm, K	2

ArTu K Series dim. 2000x390x225 (2231x538x362) mm (external hxd) IP65 with plate for Tmax T5, XT2 and modular panels, complete with 800A busbars vertically on back of structure - Icw max 35kA

Code	Description	Q.ty
AD1066	N°4 busbar adapters In=800A with bus. hold. up to 1600A	4
BA0800	Busbar In=800A	4
GD4002	DIN rail Kit without segreg.12 mod. w=400mm, K	5
KX2411	XT2 3/4P horiz. fixed without segreg. Kit, K	1
KT5412	T5 vert. fixed Kit 400x400mm (hxd)	1
LF2040	N°2 side panels 2000x350mm (hxd) K	1
PB1601	Linear busbar holder In=1600A (75 kA)	4
PC2400	Blind panel 200x400mm (hxd) K	2
PM2424	Panel 12 mod. 200x400mm (hxd) K	5
PV2041	Glass door 2000x400mm (hxd) K	1
RF2040	Rear panel 2000x400mm (hxd) K	1
SK2000	N°4 ArTu K uprights h=2000mm	1
SK2003	N°2 funct. frames h=2000mm open K	1
SK4040	ArTu K Base/Top/Base strip 400x350mm (wxd)	1
TV4000	N°2 rear crosspieces w=400mm, K	2

5

ArTu K Modular Structures

Examples of configurations

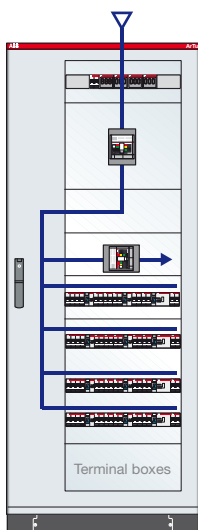

ArTu K Series dim. 2000x800x300 (2231x948x437)mm (external hxxxd) IP65 with plate for Tmax T5, T2 and modular panels, complete with 400A busbars vertically on back of structure - Icw max 35kA

Code	Description	Q.ty
AD1066	N°4 busbar adapters 400/800A	5
BA0400	Busbar In=400A	4
GD6002	DIN rail kit not segregated 24 mod. w=600mm, K	5
KT2117	Kit for T2 3/4 p. horiz. fixed 200x600mm (hxlw)	1
KT5102	Kit for T5 3/4 poles fixed + RC mod. not segregated K 500x600mm (hxd)	1
LF2050	N°2 side panels 2000x300mm (hxd) K	1
PB1603	Linear busbar holder In=1600A (65 kA)	5
PC1600	Blind panel 100x600mm (hxd) M, K	1
PC2600	Blind panel 200x600mm (hxd) M, K	1
PM2624	24 mod. Panel 200x600mm (hxd) M, K	2
PM6672	72 mod. Panel 600x600mm (hxd) M, K	1
PV2081	Glass door 2000x800mm (hxd) K	1
RF2080	Rear panel 2000x800mm (hxd) K	1
SK2000	N°4 uprights ArTu K h=2000mm	1
SK8050	Base/Top/Base strip ArTu K 800x300mm (wxd)	1
TV5101	N°2 int./ext. cable container crosspieces d=300mm	3
VC2024	Internal reduced cable container 2000x200mm (hxd) K	1

ArTu K Series dim. 2000x800x300 (2231x948x437)mm (external hxxxd) IP65 with plate for Tmax T5, XT2 and modular panels, complete with 400A busbars vertically on back of structure - Icw max 35kA

Code	Description	Q.ty
AD1066	N°4 busbar adapters 400/800A	5
BA0400	Busbar In=400A	4
GD6002	DIN rail kit not segregated 24 mod. w=600mm, K	5
KX2619	Kit for XT2 3/4 p. horiz. fixed 200x600mm (hxlw)	1
KT5102	Kit for T5 3/4 poles fixed + RC mod. not segregated K 500x600mm (hxd)	1
LF2050	N°2 side panels 2000x300mm (hxd) K	1
PB1603	Linear busbar holder In=1600A (65 kA)	5
PC1600	Blind panel 100x600mm (hxd) M, K	1
PC2600	Blind panel 200x600mm (hxd) M, K	1
PM2624	24 mod. Panel 200x600mm (hxd) M, K	2
PM6672	72 mod. Panel 600x600mm (hxd) M, K	1
PV2081	Glass door 2000x800mm (hxd) K	1
RF2080	Rear panel 2000x800mm (hxd) K	1
SK2000	N°4 uprights ArTu K h=2000mm	1
SK8050	Base/Top/Base strip ArTu K 800x300mm (wxd)	1
TV5101	N°2 int./ext. cable container crosspieces d=300mm	3
VC2024	Internal reduced cable container 2000x200mm (hxd) K	1

ArTu K Modular Structures

Examples of configurations

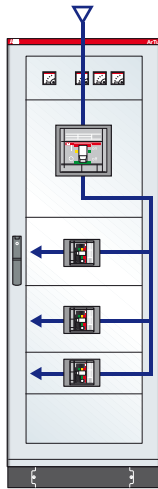

ArTu K Series dim. 1800x600x500 (2031x748x637) mm (external hxwxd) IP41 with plate for Isomax S7, Tmax T5, T2 and modular panels, complete with 1250A busbars vertically on back of structure - Icw max 50kA

Code	Description	Q.ty
AD1066	N°4 busbar adapters In=800A with busbar holders up to 1600A	1
BA0800	Busbar In=800A	1
BA1250	Busbar In=1250A	3
KT2111	S7 vert. fixed without segreg. Kit, K	1
KT5111	T2 3/4P horiz. fixed without segreg. Kit, K	2
KT7231	Hor. fixed T5 Kit+accessories 300x600mm (hxw) K	1
LA1860	N°2 ventilated side panels 1800x600mm (hxw) K	1
PB1603	Linear busbar holder In=1600A (65kA)	4
PC3600	Blind panel 100x600mm (hxw) M, K	1
PS4960	4-instrument panel 96x96 200x600mm (hxw) M, K	1
PV1861	Glass door 1800x600mm (hxw) K	1
RF1860	Rear panel 1800x600mm (hxw) K	1
SK1800	N°4 ArTu K uprights h=1800mm	1
SK1803	N°2 funct. frames h=1800mm open K	1
SK6060	ArTu K Base/Top/Base strip 600x600mm (wxd)	1
TV6001	N°2 axto frame struct. crosspieces d=600mm	2

ArTu K Series dim. 1800x600x500 (2031x748x637) mm (external hxwxd) IP41 with plate for Tmax XT2, Tmax T5, T2 and modular panels, complete with 1250A busbars vertically on back of structure - Icw max 50kA

Code	Description	Q.ty
AD1066	N°4 busbar adapters In=800A with busbar holders up to 1600A	1
BA0800	Busbar In=800A	1
BA1250	Busbar In=1250A	3
KX2611	Kit XT2 vert. fixed without segreg. Kit, K	1
KT5111	T2 3/4P horiz. fixed without segreg. Kit, K	2
KT7231	Hor. fixed T5 Kit+accessories 300x600mm (hxw) K	1
LA1860	N°2 ventilated side panels 1800x600mm (hxw) K	1
PB1603	Linear busbar holder In=1600A (65kA)	4
PC3600	Blind panel 100x600mm (hxw) M, K	1
PS4960	4-instrument panel 96x96 200x600mm (hxw) M, K	1
PV1861	Glass door 1800x600mm (hxw) K	1
RF1860	Rear panel 1800x600mm (hxw) K	1
SK1800	N°4 ArTu K uprights h=1800mm	1
SK1803	N°2 funct. frames h=1800mm open K	1
SK6060	ArTu K Base/Top/Base strip 600x600mm (wxd)	1
TV6001	N°2 axto frame struct. crosspieces d=600mm	2

ArTu K Modular Structures

Examples of configurations

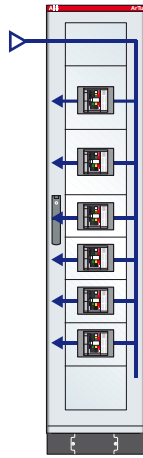

ArTu K Series dim. 1800x390x500 (2031x538x637) mm (external hxwxd) IP41 with plate for Tmax T5, T3, T2 and modular panels, complete with 1250A busbars vertically on side of structure - l_{cw} max 50kA

Code	Description	Q.ty
AD1066	N°4 busbar adapters In=800A with bus. hold. up to 1600A	1
BA0800	Busbar In=800A	1
BA1250	Busbar In=1250A	3
KT2411	T2 3/4P horiz. fixed without segreg. Kit, K	3
KT3419	T3 3/4P horiz. fixed without segreg. Kit, K	1
KT5411	T5 horiz. fixed Kit 300x400mm (h _{xw}) K	2
LA1860	N°2 ventilated side panels 1800x600mm (h _{xw}) K	1
PB1603	Linear busbar holder In=1600A (65kA)	4
PC2400	Blind panel 200x400mm (h _{xw}) K	2
PV1841	Glass door 1800x400mm (h _{xw}) K	1
RF1840	Rear panel 1800x400mm (h _{xw}) K	1
SK1800	N°4 ArTu K uprights h=1800mm	1
SK1803	N°2 funct. frames h=1800mm open K	1
SK4060	ArTu K Base/Top/Base strip 400x600mm (wxd)	1
TV6001	N°2 axto frame struct. crosspieces d=600mm	2

ArTu K Series dim. 1800x390x500 (2031x538x637) mm (external hxwxd) IP41 with plate for Tmax T5, XT3, XT2 and modular panels, complete with 1250A busbars vertically on side of structure - l_{cw} max 50kA

Code	Description	Q.ty
AD1066	N°4 busbar adapters In=800A with bus. hold. up to 1600A	1
BA0800	Busbar In=800A	1
BA1250	Busbar In=1250A	3
KX2411	kit XT2 3/4P horiz. fixed without segreg. Kit, K	3
KX3411	Kit XT3 3/4P horiz. fixed without segreg. Kit, K	1
KT5411	T5 horiz. fixed Kit 300x400mm (h _{xw}) K	2
LA1860	N°2 ventilated side panels 1800x600mm (h _{xw}) K	1
PB1603	Linear busbar holder In=1600A (65kA)	4
PC2400	Blind panel 200x400mm (h _{xw}) K	2
PV1841	Glass door 1800x400mm (h _{xw}) K	1
RF1840	Rear panel 1800x400mm (h _{xw}) K	1
SK1800	N°4 ArTu K uprights h=1800mm	1
SK1803	N°2 funct. frames h=1800mm open K	1
SK4060	ArTu K Base/Top/Base strip 400x600mm (wxd)	1
TV6001	N°2 axto frame struct. crosspieces d=600mm	2

ArTu K Modular Structures

Examples of configurations

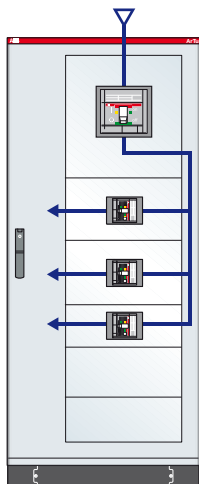

**ArTu K Series dim. 1800x800x500 (2031x948x637) mm (external hxwxd)
IP41 with plate Tmax T7, T5, T2 and modular panels, complete with 1250A
busbars vertically on side of internal cable riser - l_{cw} max 35kA**

Code	Description	Q.ty
AD1066	N°4 busbar adapters I _n =800A with bus. hold. up to 1600A	1
BA0800	Busbar I _n =800A	1
BA1250	Busbar I _n =1250A	3
KT2111	T2 3/4P horiz. fixed without segreg. Kit, K	1
KT5111	Hor. fixed T5 Kit+accessories 300x600mm (hxw) K	2
KT7231	S7 vert. fixed without segreg. Kit, K	1
LA1860	N°2 ventilated side panels 1800x600mm (hxw) K	1
PB1603	Linear busbar holder I _n =1600A (65kA)	3
PC2600	Blind panel 100x600mm (hxw) M, K	2
PV1881	Blind panel 200x600mm (hxw) M, K	1
RF1880	Glass door 1800x800mm (hxw) K	1
SK1800	N°4 ArTu K uprights h=1800mm	1
SK8060	ArTu K Base/Top/Base strip 800x600mm (wxd)	1
TV6101	N°2 int./ext. cable cont. crosspieces d=600mm	2
VC1823	Internal cable cont. 1800x200mm (hxw) K	1

**ArTu K Series dim. 1800x800x500 (2031x948x637) mm (external hxwxd)
IP41 with plate Tmax T7, T5, XT2 and modular panels, complete with
1250A busbars vertically on side of internal cable riser - l_{cw} max 35kA**

Code	Description	Q.ty
AD1066	N°4 busbar adapters I _n =800A with bus. hold. up to 1600A	1
BA0800	Busbar I _n =800A	1
BA1250	Busbar I _n =1250A	3
KT2611	XT2 3/4P horiz. fixed without segreg. Kit, K	1
KT5111	Hor. fixed T5 Kit+accessories 300x600mm (hxw) K	2
KT7231	S7 vert. fixed without segreg. Kit, K	1
LA1860	N°2 ventilated side panels 1800x600mm (hxw) K	1
PB1603	Linear busbar holder I _n =1600A (65kA)	3
PC2600	Blind panel 100x600mm (hxw) M, K	2
PV1881	Blind panel 200x600mm (hxw) M, K	1
RF1880	Glass door 1800x800mm (hxw) K	1
SK1800	N°4 ArTu K uprights h=1800mm	1
SK8060	ArTu K Base/Top/Base strip 800x600mm (wxd)	1
TV6101	N°2 int./ext. cable cont. crosspieces d=600mm	2
VC1823	Internal cable cont. 1800x200mm (hxw) K	1

5

ArTu K Modular Structures

Examples of configurations

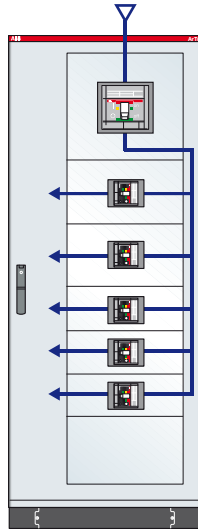

ArTu K Series dim. 2000x800x500 (2231x948x637)mm (external hxwxd) P41 with kit for Tmax T6, T5, T3, complete with 1600A busbars vertically on side on side of internal cable riser - l_{cw} max 65kA

Code	Description	Q.ty
BA1250	Busbar In=1250A	1
BA1600	Busbar In=1600A	3
KT3119	Kit for T3 3/4P horizontal fixed not segregated K	3
KT5111	Kit for T5 horizontal fixed +accessories 300x600mm (h _{xw}) K	2
KT6211	Kit for T6 vertical fixed without segregation K	1
LA2060	N°2 ventilated side panels 2000x600mm (h _{xw}) K	1
PB1601	Linear busbar holder In=1600A (75 kA)	7
PC3600	Blind panel 300x600mm (h _{xw}) M, K	1
PV2081	Glass door 2000x800mm (h _{xw}) K	1
RF2080	Rear panel 2000x800mm (h _{xw}) K	1
SK2000	N°4 uprights ArTu K h=2000mm	1
SK8060	Base/Top/Base strip ArTu K 800x600mm (wxd)	1
TV6101	N°2 int./ext. cable container crosspieces d=600mm	4
VC2023	Internal cable container. 2000x200mm (h _{xw}) K	1

ArTu K Series dim. 2000x800x500 (2231x948x637)mm (external hxwxd) P41 with kit for Tmax T6, T5, XT3, complete with 1600A busbars vertically on side on side of internal cable riser - l_{cw} max 65kA

Code	Description	Q.ty
BA1250	Busbar In=1250A	1
BA1600	Busbar In=1600A	3
KX3611	Kit for XT3 3/4P horizontal fixed not segregated K	3
KT5111	Kit for T5 horizontal fixed +accessories 300x600mm (h _{xw}) K	2
KT6211	Kit for T6 vertical fixed without segregation K	1
LA2060	N°2 ventilated side panels 2000x600mm (h _{xw}) K	1
PB1601	Linear busbar holder In=1600A (75 kA)	7
PC3600	Blind panel 300x600mm (h _{xw}) M, K	1
PV2081	Glass door 2000x800mm (h _{xw}) K	1
RF2080	Rear panel 2000x800mm (h _{xw}) K	1
SK2000	N°4 uprights ArTu K h=2000mm	1
SK8060	Base/Top/Base strip ArTu K 800x600mm (wxd)	1
TV6101	N°2 int./ext. cable container crosspieces d=600mm	4
VC2023	Internal cable container. 2000x200mm (h _{xw}) K	1

5

ArTu K Modular Structures

Examples of configurations

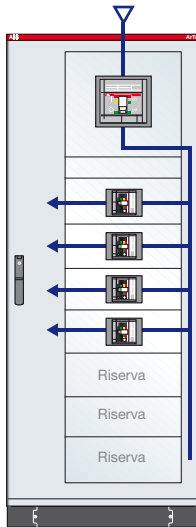

**ArTu K Series dim. 2000x800x500 (2231x948x637)mm (external hwxwd)
IP65 with kit for Tmax T6, T3, T2, complete with 1600A busbars vertically on side on side of internal cable riser - l_{cw} max 65kA**

Code	Description	Q.ty
BA1250	Busbar In=1250A	1
BA1600	Busbar In=1600A	3
KT2111	Kit for T2 3/4P horiz. fixed not segregated K	2
KT3119	Kit for T3 3/4P horiz. fixed not segregated K	2
KT6211	Kit for T6 vert. fixed not segregated K	1
LA2060	N°2 ventilated side panels 2000x600mm (hwx) K	1
PB1601	Linear busbar holder In=1600A (75 kA)	7
PC1600	Blind panel 100x600mm (hwx) M, K	1
PC2600	Blind panel 200x600mm (hwx) M, K	3
PV2081	Glass door 2000x800mm (hwx) K	1
RF2080	Rear panel 2000x800mm (hwx) K	1
SK2000	N°4 uprights ArTu K h=2000mm	1
SK8060	Base/Top/Base strip ArTu K 800x600mm (wxd)	1
TV6101	N°2 int./ext. cable container crosspieces d=600mm	4
VC2023	Internal cable container 2000x200mm (hwx) K	1

**ArTu K Series dim. 2000x800x500 (2231x948x637)mm (external hwxwd)
IP65 with kit for Tmax T6, XT3, XT2, complete with 1600A busbars vertically on side on side of internal cable riser - l_{cw} max 65kA**

Code	Description	Q.ty
BA1250	Busbar In=1250A	1
BA1600	Busbar In=1600A	3
KX2611	Kit for XT2 3/4P horiz. fixed not segregated K	2
KX3611	Kit for XT3 3/4P horiz. fixed not segregated K	2
KT6211	Kit for T6 vert. fixed not segregated K	1
LA2060	N°2 ventilated side panels 2000x600mm (hwx) K	1
PB1601	Linear busbar holder In=1600A (75 kA)	7
PC1600	Blind panel 100x600mm (hwx) M, K	1
PC2600	Blind panel 200x600mm (hwx) M, K	3
PV2081	Glass door 2000x800mm (hwx) K	1
RF2080	Rear panel 2000x800mm (hwx) K	1
SK2000	N°4 uprights ArTu K h=2000mm	1
SK8060	Base/Top/Base strip ArTu K 800x600mm (wxd)	1
TV6101	N°2 int./ext. cable container crosspieces d=600mm	4
VC2023	Internal cable container 2000x200mm (hwx) K	1

5

ArTu K Modular Structures

Examples of configurations

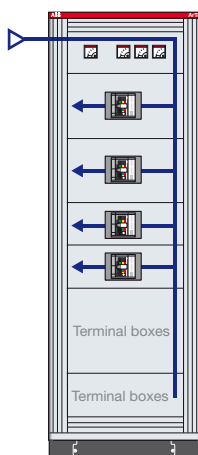

ArTu K Series Form 3/4 segregation dim.1800x600x700 (2031x748x837) mm (external hxwxd) IP31 with plate for Tmax T5, T3, T2, complete with 1600A busbars vertically on side of structure - Icw max 50kA

Code	Description	Q.ty
BA1250	Busbar In=1250A	1
BA1600	Busbar In=1600A	3
IP3060	N°2 hor. finishing sections w=600mm K	1
IP3180	N°2 vert. finishing sections IP31 h=1800mm K	1
KT2110	T2 3/4P hor. fixed segreg. Kit, K	2
KT3110	T3 3/4P hor. fixed segreg. Kit, K	1
KT5136	T5 segr. hor. fixed Kit 300x600mm(hxw)K	1
LA1880	N°2 ventilated side panels 1800x800mm (hxw) K	1
PB1601	Linear busbar holder In=1600A (75 kA)	5
PC2600	Blind panel 200x600mm (hxw) M, K	1
PC4600	Blind panel 400x600mm (hxw) M, K	1
PF2005	Plain plate 200x600mm (hxw) segreg. K	2
PF4005	Plain plate 400x600mm (hxw) segreg. K	1
PS4960	4-instrument panel 96x96 200x600mm (hxw)M, K	1
RF1860	Rear panel 1800x600mm (hxw) K	1
SH2030	Busbar hor. segregation w=600mm, K, PC	1
SH6000	Busbar hor. shelf w=600mm, K	2
SK1800	N°4 ArTu K uprights h=1800mm	1
SK1802	N°2 funct. frames h=1800mm closed K	1
SK6080	ArTu K Base/Top/Base strip 600x700mm (wxd)	1
SV2061	Busbar vert. segregation 200x600mm (hxw) K	1
TV8005	N°2 funct. frame struct. crosspieces d=800mm	3

Segregation Form 3

FH3540	F3 horiz. segreg. Kit 400x600mm (hxw) K	1
FH3430	F3 horiz. segreg. Kit 200x600mm (hxw) K	4
FH3220	F3 horiz. segreg. Kit 300x600mm (hxw) K	2

Segregation Form 4

FH4220	Fairlead plate F4 h=200mm	2
FH4430	Fairlead plate F4 h=300mm	1
FH4540	Fairlead plate F4 h=400mm	1

ArTu K Series Form 3/4 segregation dim.1800x600x700 (2031x748x837) mm (external hxwxd) IP31 with plate for Tmax T5, XT3, XT2, complete with 1600A busbars vertically on side of structure - Icw max 50kA

Code	Description	Q.ty
BA1250	Busbar In=1250A	1
BA1600	Busbar In=1600A	3
IP3060	N°2 hor. finishing sections w=600mm K	1
IP3180	N°2 vert. finishing sections IP31 h=1800mm K	1
KX2611	XT2 3/4P hor. fixed segreg. Kit, K	2
KX3611	XT3 3/4P hor. fixed segreg. Kit, K	1
KT5136	T5 segr. hor. fixed Kit 300x600mm(hxw)K	1
LA1880	N°2 ventilated side panels 1800x800mm (hxw) K	1
PB1601	Linear busbar holder In=1600A (75 kA)	5
PC2600	Blind panel 200x600mm (hxw) M, K	1
PC4600	Blind panel 400x600mm (hxw) M, K	1
PF2005	Plain plate 200x600mm (hxw) segreg. K	2
PF4005	Plain plate 400x600mm (hxw) segreg. K	1
PS4960	4-instrument panel 96x96 200x600mm (hxw)M, K	1
RF1860	Rear panel 1800x600mm (hxw) K	1
SH2030	Busbar hor. segregation w=600mm, K, PC	1
SH6000	Busbar hor. shelf w=600mm, K	2
SK1800	N°4 ArTu K uprights h=1800mm	1
SK1802	N°2 funct. frames h=1800mm closed K	1
SK6080	ArTu K Base/Top/Base strip 600x700mm (wxd)	1
SV2061	Busbar vert. segregation 200x600mm (hxw) K	1
TV8005	N°2 funct. frame struct. crosspieces d=800mm	3

Segregation Form 3

FH3540	F3 horiz. segreg. Kit 400x600mm (hxw) K	1
FH3430	F3 horiz. segreg. Kit 200x600mm (hxw) K	4
FH3220	F3 horiz. segreg. Kit 300x600mm (hxw) K	2

Segregation Form 4

FH4220	Fairlead plate F4 h=200mm	2
FH4430	Fairlead plate F4 h=300mm	1
FH4540	Fairlead plate F4 h=400mm	1

ArTu K Modular Structures

Examples of configurations

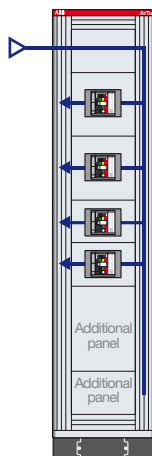

ArTu K Series Form 3/4 segregation dim.1800x390x700 (2031x538x837) mm (external hxwxd) IP31 with plate for Tmax T5, T3, T2 and modular panels, complete with 1600A busbars vertically on side of structure - Icw max 50kA

Code	Description	Q.ty
BA1250	Busbar In=1250A	1
BA1600	Busbar In=1600A	3
IP3040	N°2 hor. finishing sections IP31 w=400mm K	1
IP3180	N°2 vert. finishing sections IP31 h=1800mm K	1
KT2410	T2 3/4P hor. fixed segreg. Kit, K	2
KT3410	T3 3/4P hor. fixed segreg. Kit, K	1
KT5122	T5 segr. hor. fixed Kit 300x400mm(hxw)K	1
LA1880	N°2 ventilated side panels 1800x800mm (hxw) K	1
PB1601	Linear busbar holder In=1600A (75 kA)	5
PC2400	Blind panel 200x400mm (hxw) K	2
PC4400	Blind panel 400x400mm (hxw) K	1
PF2405	Plain plate 200x400mm (hxw) segreg. K	2
PF4405	Plain plate 400x400mm (hxw) segreg. K	1
RF1840	Rear panel 1800x400mm (hxw) K	1
SH4000	Busbar hor. shelf w=400mm, K	2
SH4030	Busbar hor. segregation w=400mm, K	1
SK1800	N°4 ArTu K uprigh ts h=1800mm	1
SK1802	N°2 funct. frames h=1800mm closed K	1
SK4080	ArTu K Base/Top/Base strip 400x800mm (wxd)	1
SV4061	Busbar vert. segregation 200x400mm (hxw) K	1
TV8005	N°2 funct. frame struct. crosspieces d=800mm	3

Segregation Form 3

FH3220	F3 horiz. segreg. Kit 200x600mm (hxw) K	4
FH3430	F3 horiz. segreg. Kit 300x600mm (hxw) K	2
FH3540	F3 horiz. segreg. Kit 400x600mm (hxw) K	1

Segregation Form 4

FH4220	Fairlead plate F4 h=200mm	
FH4430	Fairlead plate F4 h=300mm	
FH4540	Fairlead plate F4 h=400mm	1

ArTu K Series Form 3/4 segregation dim.1800x390x700 (2031x538x837) mm (external hxwxd) IP31 with plate for Tmax T5, XT3, XT2 and modular panels, complete with 1600A busbars vertically on side of structure - Icw max 50kA

Code	Description	Q.ty
BA1250	Busbar In=1250A	1
BA1600	Busbar In=1600A	3
IP3040	N°2 hor. finishing sections IP31 w=400mm K	1
IP3180	N°2 vert. finishing sections IP31 h=1800mm K	1
KX2411	XT2 3/4P hor. fixed segreg. Kit, K	2
KX3411	XT3 3/4P hor. fixed segreg. Kit, K	1
KT5122	T5 segr. hor. fixed Kit 300x400mm(hxw)K	1
LA1880	N°2 ventilated side panels 1800x800mm (hxw) K	1
PB1601	Linear busbar holder In=1600A (75 kA)	5
PC2400	Blind panel 200x400mm (hxw) K	2
PC4400	Blind panel 400x400mm (hxw) K	1
PF2405	Plain plate 200x400mm (hxw) segreg. K	2
PF4405	Plain plate 400x400mm (hxw) segreg. K	1
RF1840	Rear panel 1800x400mm (hxw) K	1
SH4000	Busbar hor. shelf w=400mm, K	2
SH4030	Busbar hor. segregation w=400mm, K	1
SK1800	N°4 ArTu K uprigh ts h=1800mm	1
SK1802	N°2 funct. frames h=1800mm closed K	1
SK4080	ArTu K Base/Top/Base strip 400x800mm (wxd)	1
SV4061	Busbar vert. segregation 200x400mm (hxw) K	1
TV8005	N°2 funct. frame struct. crosspieces d=800mm	3

Segregation Form 3

FH3220	F3 horiz. segreg. Kit 200x600mm (hxw) K	4
FH3430	F3 horiz. segreg. Kit 300x600mm (hxw) K	2
FH3540	F3 horiz. segreg. Kit 400x600mm (hxw) K	1

Segregation Form 4

FH4220	Fairlead plate F4 h=200mm	
FH4430	Fairlead plate F4 h=300mm	
FH4540	Fairlead plate F4 h=400mm	1

ArTu K Modular Structures

Examples of configurations

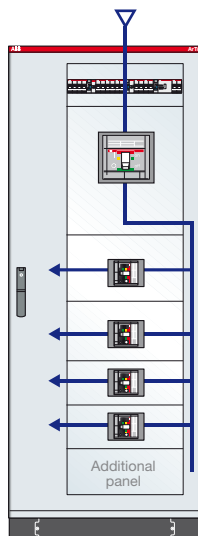

ArTu K Series Form 3/4 segregation dim.2000x800x700 (2231x948x837) mm (external hxwxd) IP65 with plate for Tmax T6, T3, T2 and modular panels, complete with 1600A busbars vertically on side of structure - lcv max 50kA

Code	Description	Q.ty
BA1250	Busbar In=1250A	1
BA1600	Busbar In=1600A	3
GD7005	DIN rail Kit w=700mm segreg. K, PC	1
KT2110	T2 3/4P hor. fixed segreg. Kit, K	2
KT3110	T3 3/4P hor. fixed segreg. Kit, K	2
KT6210	T6 vert. fixed segreg. Kit, K	1
LA2080	N°2 ventilated side panels 2000x800mm (hwx) K	1
PB1601	Linear busbar holder In=1600A (75 kA)	5
PC2600	Blind panel 200x600mm (hwx) M, K	1
PF2005	Plain plate 200x600mm (hwx) segreg. K	2
PM2624	Panel 24 mod. 200x600mm (hwx) M, K	1
PV2081	Glass door 2000x800mm (hwx) K	1
RF2080	Rear panel 2000x800mm (hwx) K	1
SH2030	Busbar hor. segregation w=600mm, K, PC	1
SH6000	Busbar hor. shelf w=600mm, K	2
SK2000	N°4 ArTu K uprights h=2000mm	1
SK8080	ArTu K Base/Top/Base strip 800x800mm (wxd)	1
SV2061	Busbar vert. segregation 200x600mm (hwx) K	1
TV8101	N°2 int./ext. cable cont. crosspieces d=800mm	3
VC2020	Cable container int. segreg. 2000x200mm (hwx) K	1

Segregation Form 3

FH3220	F3 hor iz. segreg. Kit 200x600mm (hwx) K	4
FH3430	F3 horiz. segreg. Kit 300x600mm (hwx) K	2
FV3668	S6 vert. F3 segreg. Kit600x800mm (hxd)	1

Segregation Form 4

FH4220	Fairlead plate F4 h=200mm	3
FH4430	Fairlead plate F4 h=300mm	2
FV4668	Fairlead plate F4 vert. d=800mm	1

ArTu K Series Form 3/4 segregation dim.2000x800x700 (2231x948x837) mm (external hxwxd) IP65 with plate for Tmax T6, XT3, XT2 and modular panels, complete with 1600A busbars vertically on side of structure - lcv max 50kA

Code	Description	Q.ty
BA1250	Busbar In=1250A	1
BA1600	Busbar In=1600A	3
GD7005	DIN rail Kit w=700mm segreg. K, PC	1
KX2611	XT2 3/4P hor. fixed segreg. Kit, K	2
KX3611	XT3 3/4P hor. fixed segreg. Kit, K	2
KT6210	T6 vert. fixed segreg. Kit, K	1
LA2080	N°2 ventilated side panels 2000x800mm (hwx) K	1
PB1601	Linear busbar holder In=1600A (75 kA)	5
PC2600	Blind panel 200x600mm (hwx) M, K	1
PF2005	Plain plate 200x600mm (hwx) segreg. K	2
PM2624	Panel 24 mod. 200x600mm (hwx) M, K	1
PV2081	Glass door 2000x800mm (hwx) K	1
RF2080	Rear panel 2000x800mm (hwx) K	1
SH2030	Busbar hor. segregation w=600mm, K, PC	1
SH6000	Busbar hor. shelf w=600mm, K	2
SK2000	N°4 ArTu K uprights h=2000mm	1
SK8080	ArTu K Base/Top/Base strip 800x800mm (wxd)	1
SV2061	Busbar vert. segregation 200x600mm (hwx) K	1
TV8101	N°2 int./ext. cable cont. crosspieces d=800mm	3
VC2020	Cable container int. segreg. 2000x200mm (hwx) K	1

Segregation Form 3

FH3220	F3 hor iz. segreg. Kit 200x600mm (hwx) K	4
FH3430	F3 horiz. segreg. Kit 300x600mm (hwx) K	2
FV3668	S6 vert. F3 segreg. Kit600x800mm (hxd)	1

Segregation Form 4

FH4220	Fairlead plate F4 h=200mm	3
FH4430	Fairlead plate F4 h=300mm	2
FV4668	Fairlead plate F4 vert. d=800mm	1

ArTu K Modular Structures

Examples of configurations

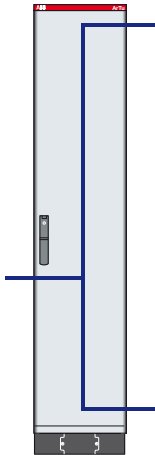

ArTu K Series dim. 1800x300x700 (2031x420x837) mm (external hwxwd) IP65 complete with 1250A busbars vertically on side of cable riser - Icw max 50kA

Code	Description	Q.ty
AD1014	Lateral side-by-side Kit, K	1
AD1066	N°4 busbar adapters In=800A with busbar holder up to 1600A	2
BA0800	Busbar In=800A	1
BA1250	Busbar In=1250A	3
PB1600	Scaled busbar holder In=1600A (75 kA)	5
PO1831	Blind door 1800x300mm (hwx) L, M int.	1
PO1833	Blind door 1800x300mm (hwx) K ext.	1
RF1830	Cable container rear panel 1800x300mm (hwx) K	1
SK1800	N°4 ArTu K uprights h=1800mm	1
TV8101	N°2 int./ext. cable cont. crosspieces d=800mm	3
VC3080	Cable container 300x800mm (wxd) K	1

ArTu K Modular Structures

Examples of configurations

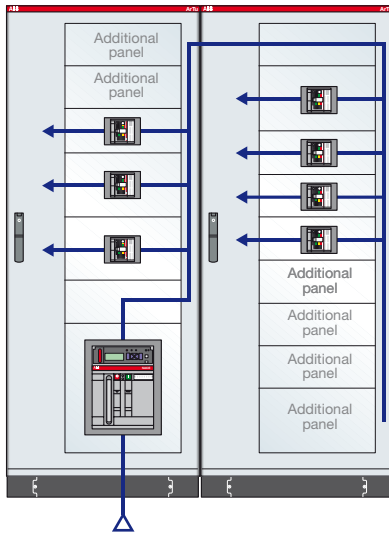

ArTu K Series 2 x dim.2000x1600x700 (2231x1924x837) mm (external hxxxd) IP65 complete with 1600A horizontal and 1250A vertical busbars - l_{cw} max 75kA

Code	Description	Q.ty
AD1014	Lateral side-by-side Kit, K	1
AD1064	N°12 coupling screws w=27 x flat up to 10mm	4
AD1066	N°4 busbar adapters I _n =800A with busbar holders up to 1600A	2
AD1069	N°4 connect. coupling busbars from 1250/1600A to 800A	1
BA0800	Busbar I _n =800A	1
BA1250	Busbar I _n =1250A	4
BA1600	Busbar I _n =1600A	3
KE3215	Kit per Emax E1, E2, E3 vert. fixed	1
KT2111	T2 Kit 3/4P horiz. fixed without segreg. K	2
KT4111	T4 Kit hor. fixed+access. 200x600mm (h _{xw}) K	2
KT5111	Hor. fixed T5 Kit+accessories 300x600mm (h _{xw}) K	3
LF2080	N°2 side panels 2000x800mm (h _{xd}) K	1
PB1601	Linear busbar holder I _n =1600A (75 kA)	10
PC2600	Blind panel 200x600mm (h _{xw}) M, K	7
PC3600	Blind panel 300x600mm (h _{xw}) M, K	1
PV2081	Glass door 2000x800mm (h _{xw}) K	2
RF2080	Rear panel 2000x800mm (h _{xw}) K	2
SK2000	N°4 ArTu K uprights h=2000mm	2
SK8080	ArTu K Base/Top/Base strip 800x800mm (wxd)	2
TV8001	N°2 open frame structure crosspieces d=800mm	3
TV8211	N°2 structure crosspieces w=800mm	2
VC2023	Internal cable cont.2000x200mm (h _{xw}) K	2

ArTu K Series 2 x dim.2000x1600x700 (2231x1924x837) mm (external hxxxd) IP65 complete with 1600A horizontal and 1250A vertical busbars - l_{cw} max 75kA

Code	Description	Q.ty
AD1014	Lateral side-by-side Kit, K	1
AD1064	N°12 coupling screws w=27 x flat up to 10mm	4
AD1066	N°4 busbar adapters I _n =800A with busbar holders up to 1600A	2
AD1069	N°4 connect. coupling busbars from 1250/1600A to 800A	1
BA0800	Busbar I _n =800A	1
BA1250	Busbar I _n =1250A	4
BA1600	Busbar I _n =1600A	3
KE3215	Kit per Emax E1, E2, E3 vert. fixed	1
KX2611	XT2 Kit 3/4P horiz. fixed without segreg. K	2
KX4611	XT4 Kit hor. fixed+access. 200x600mm (h _{xw}) K	2
KT5111	Hor. fixed T5 Kit+accessories 300x600mm (h _{xw}) K	3
LF2080	N°2 side panels 2000x800mm (h _{xd}) K	1
PB1601	Linear busbar holder I _n =1600A (75 kA)	10
PC2600	Blind panel 200x600mm (h _{xw}) M, K	7
PC3600	Blind panel 300x600mm (h _{xw}) M, K	1
PV2081	Glass door 2000x800mm (h _{xw}) K	2
RF2080	Rear panel 2000x800mm (h _{xw}) K	2
SK2000	N°4 ArTu K uprights h=2000mm	2
SK8080	ArTu K Base/Top/Base strip 800x800mm (wxd)	2
TV8001	N°2 open frame structure crosspieces d=800mm	3
TV8211	N°2 structure crosspieces w=800mm	2
VC2023	Internal cable cont.2000x200mm (h _{xw}) K	2

ArTu K Modular Structures

Examples of configurations

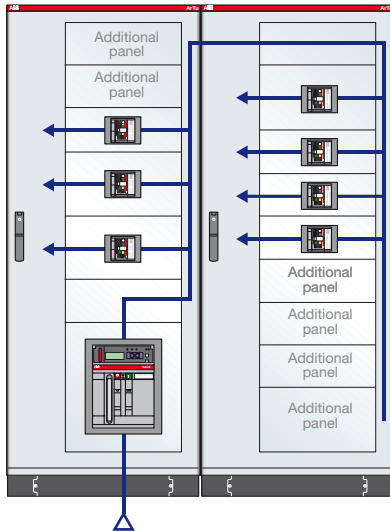

ArTu K Series 2 x dim.2000x1600x700 (2231x1924x837) mm (external hwxwd) IP65 complete with 3200A horizontal and 1250A vertical busbars - Icw max 75kA

Code	Description	Q.ty
AD1014	Lateral side-by-side Kit, K	1
AD1064	N°12 coupling screws w=27 x flat up to 10mm	4
AD1066	N°4 busbar adapters In=800A with busbar holders up to 1600A	2
AD1078	N°4 connect. coupling busbars from 3200A to 1600/1250A	2
BA0800	Busbar In=800A	2
BA1250	Busbar In=1250A	6
BA2000	Busbar In=2000A	7
KE3215	Kit per Emax E1, E2, E3 vert. fixed	1
KT2111	T2 Kit 3/4P horiz. fixed without segreg. K	2
KT4111	T4 Kit hor. fixed+access. 200x600mm (hwxw) K	2
KT5111	Hor. fixed T5 Kit+accessories 300x600mm (hwxw) K	3
LF2080	N°2 side panels 2000x800mm (hxd) K	1
PB1601	Linear busbar holder In=1600A (75 kA)	14
PB3201	Linear busbar holder In=3200A (75 kA)	6
PC2600	Blind panel 200x600mm (hwxw) M, K	7
PC3600	Blind panel 300x600mm (hwxw) M, K	1
PV2081	Glass door 2000x800mm (hwxw) K	2
RF2080	Rear panel 2000x800mm (hwxw) K	2
SK2000	N°4 ArTu K uprights h=2000mm	2
SK8080	ArTu K Base/Top/Base strip 800x800mm (wxd)	2
TV8001	N°2 Open frame struct. crosspieces d=800mm	3
TV8211	N°2 structure crosspieces w=800mm	3
VC2023	Int. reduced cable cont.2000x200mm (hwxw) K	2

ArTu K Series 2 x dim.2000x1600x700 (2231x1924x837) mm (external hwxwd) IP65 complete with 3200A horizontal and 1250A vertical busbars - Icw max 75kA

Code	Description	Q.ty
AD1014	Lateral side-by-side Kit, K	1
AD1064	N°12 coupling screws w=27 x flat up to 10mm	4
AD1066	N°4 busbar adapters In=800A with busbar holders up to 1600A	2
AD1078	N°4 connect. coupling busbars from 3200A to 1600/1250A	2
BA0800	Busbar In=800A	2
BA1250	Busbar In=1250A	6
BA2000	Busbar In=2000A	7
KE3215	Kit per Emax E1, E2, E3 vert. fixed	1
KX2611	XT2 Kit 3/4P horiz. fixed without segreg. K	2
KX4611	XT4 Kit hor. fixed+access. 200x600mm (hwxw) K	2
KT5111	Hor. fixed T5 Kit+accessories 300x600mm (hwxw) K	3
LF2080	N°2 side panels 2000x800mm (hxd) K	1
PB1601	Linear busbar holder In=1600A (75 kA)	14
PB3201	Linear busbar holder In=3200A (75 kA)	6
PC2600	Blind panel 200x600mm (hwxw) M, K	7
PC3600	Blind panel 300x600mm (hwxw) M, K	1
PV2081	Glass door 2000x800mm (hwxw) K	2
RF2080	Rear panel 2000x800mm (hwxw) K	2
SK2000	N°4 ArTu K uprights h=2000mm	2
SK8080	ArTu K Base/Top/Base strip 800x800mm (wxd)	2
TV8001	N°2 Open frame struct. crosspieces d=800mm	3
TV8211	N°2 structure crosspieces w=800mm	3
VC2023	Int. reduced cable cont.2000x200mm (hwxw) K	2

ArTu K Modular Structures

Examples of configurations



**ArTu K Series dim. 2000x600x500 (2231x748x637) mm (external hxwxd)
IP65 with back plate h=2000**

Code	Description	Q.ty
AD1050	N°2 pair of tracks x back plate w=600mm	1
LF2060	N°2 side panels 2000x600mm (hxd) K	1
PF2006	Plain plate 2000x600mm (hwx) K	1
PO2061	Blind door 2000x600mm (hwx) K	1
RF2060	Rear panel 2000x600mm (hwx) K	1
SK2000	N°4 ArTu K uprights h=2000mm	1
SK6060	ArTu K Base/Top/Base strip 600x600mm (wxd)	1

ArTu K Modular Structures

Examples of configurations

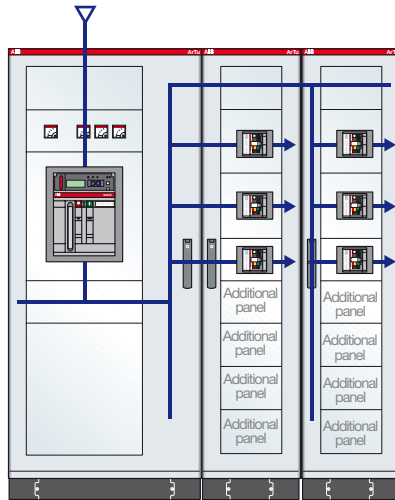

ArTu K Series dim. 1800x1580x700 (2031x1984x837) mm (external hxd) IP65 with Emax E1, T5 and XT3, 1600A omnibus busbars and vertical 800A branches - Icw 50kA

ArTu K Series dim. 1800x1580x700 (2031x1984x837) mm (external hxd) IP65 with Emax E1, T5 and T3, 1600A omnibus busbars and vertical 800A branches - Icw 50kA

Code	Description	Q.ty
AD1014	Lateral side-by-side Kit, K	2
AD1066	N°4 busbar adapters In=800A with busbar holders up to 1600A	4
AD1069	N°4 connect. coupling busbars from 1250/1600A to 800A	2
BA0800	Busbar In=800A	4
BA1600	Busbar In=1600A	10
KE3215	Kit E1, E2, E3 vert. fixed without segreg. K	1
KX3411	XT3 Kit 3/4P horiz. fixed without segreg. K	2
KT5411	T5 Kit horiz. fixed 300x400mm (hxd) K	4
LF1880	N°2 side panels 1800x800mm (hxd) K	1
PB1601	Linear busbar holder In=1600A (75 kA)	8
PC2400	Blind panel 200x400mm (hxd) K	10
PC2600	Blind panel 200x600mm (hxd) M, K	2
PC6600	Blind panel 600x600mm (hxd) M, K	1
PS4720	4-instrument panel 72x72 200x600mm (hxd) M, K	1
PV1841	Glass door 1800x400mm (hxd) K	2
PV1881	Glass door 1800x800mm (hxd) K	1
RF1840	Rear panel 1800x400mm (hxd) K	2
RF1880	Rear panel 1800x800mm (hxd) K	1
SK1800	N°4 ArTu K uprights h=1800mm	3
SK1803	N°2 funct. frames h=1800mm open K	2
SK1880	Open frame int. cable cont. rear assembly h=1800mm	1
SK4080	ArTu K Base/Top/Base strip 400x800mm (wxd)	2
SK8080	ArTu K Base/Top/Base strip 800x800mm (wxd)	1
TV6221	N°2 funct. frame struct. crosspieces w=600mm	1
TV8001	N°2 Open frame struct. crosspieces d=800mm	2
TV8011	N°2 structure crosspieces d=800mm	1
TV8211	N°2 structure crosspieces w=800mm	2
VC1823	Int. reduced cable cont.1800x200mm (hxd) K	1

Code	Description	Q.ty
AD1014	Lateral side-by-side Kit, K	2
AD1066	N°4 busbar adapters In=800A with busbar holders up to 1600A	4
AD1069	N°4 connect. coupling busbars from 1250/1600A to 800A	2
BA0800	Busbar In=800A	4
BA1600	Busbar In=1600A	10
KE3215	Kit E1, E2, E3 vert. fixed without segreg. K	1
KT3419	T3 Kit 3/4P horiz. fixed without segreg. K	2
KT5411	T5 Kit horiz. fixed 300x400mm (hxd) K	4
LF1880	N°2 side panels 1800x800mm (hxd) K	1
PB1601	Linear busbar holder In=1600A (75 kA)	8
PC2400	Blind panel 200x400mm (hxd) K	10
PC2600	Blind panel 200x600mm (hxd) M, K	2
PC6600	Blind panel 600x600mm (hxd) M, K	1
PS4720	4-instrument panel 72x72 200x600mm (hxd) M, K	1
PV1841	Glass door 1800x400mm (hxd) K	2
PV1881	Glass door 1800x800mm (hxd) K	1
RF1840	Rear panel 1800x400mm (hxd) K	2
RF1880	Rear panel 1800x800mm (hxd) K	1
SK1800	N°4 ArTu K uprights h=1800mm	3
SK1803	N°2 funct. frames h=1800mm open K	2
SK1880	Open frame int. cable cont. rear assembly h=1800mm	1
SK4080	ArTu K Base/Top/Base strip 400x800mm (wxd)	2
SK8080	ArTu K Base/Top/Base strip 800x800mm (wxd)	1
TV6221	N°2 funct. frame struct. crosspieces w=600mm	1
TV8001	N°2 Open frame struct. crosspieces d=800mm	2
TV8011	N°2 structure crosspieces d=800mm	1
TV8211	N°2 structure crosspieces w=800mm	2
VC1823	Int. reduced cable cont.1800x200mm (hxd) K	1

ArTu K Modular Structures

Examples of configurations

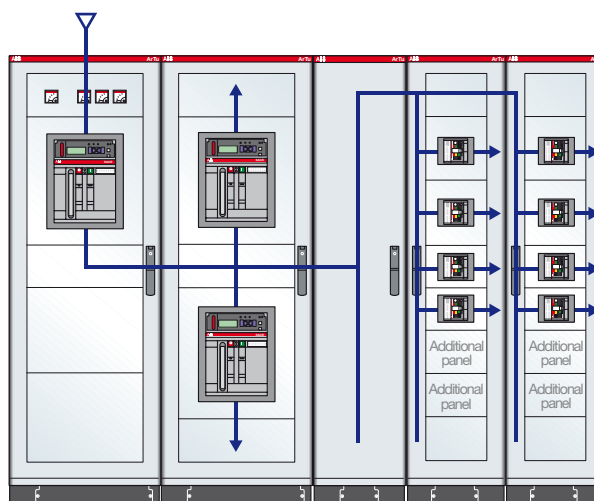

ArTu K Series dim. 1800x2280x700 (2031x2904x837) mm (external hwxwd) IP65 with Emax E1, T5 and T3, 1600A omnibus busbars and vertical 1250A branches - Icw 50kA

Code	Description	Q.ty
AD1014	Lateral side-by-side Kit, K	4
AD1069	N°4 connect. coupling busbars from 1250/1600A to 800A	3
BA1250	Busbar In=1250A	4
BA1600	Busbar In=1600A	12
KE3215	Kit E1, E2, E3 vert. fixed without segreg. K	3
KT3419	T3 Kit 3/4P horiz. fixed without segreg. K	4
KT5411	T5 Kit horiz. fixed 300x400mm (hwx) K	4
LF1880	N°2 side panels 1800x800mm (hxd) K	1
PB1601	Linear busbar holder In=1600A (75 kA)	10
PC2400	Blind panel 200x400mm (hwx) K	8
PC2600	Blind panel 200x600mm (hwx) M, K	5
PC6600	Blind panel 600x600mm (hwx) M, K	1
PO1831	Blind door 1800x300mm (hwx) L, M int.	1
PO1833	Blind door 1800x300mm (hwx) K ext.	1
PS4720	4-instrument panel 72x72 200x600mm (hwx)M, K	1
PV1841	Glass door 1800x400mm (hwx) K	2
PV1861	Glass door 1800x600mm (hwx) K	2
RF1830	Cable container rear panel 1800x300mm (hwx) K	1
RF1840	Rear panel 1800x400mm (hwx) K	2
RF1860	Rear panel 1800x600mm (hwx) K	2
SK1800	N°4 ArTu K uprights h=1800mm	5
SK1803	N°2 funct. frames h=1800mm open K	4
SK4080	ArTu K Base/Top/Base strip 400x800mm (wxd)	2
SK6080	ArTu K Base/Top/Base strip 600x800mm (wxd)	2
TV6221	N°2 funct. frame struct. crosspieces w=600mm	2
TV8001	N°2 Open frame struct. crosspieces d=800mm	2
TV8011	N°2 structure crosspieces d=800mm	2
TV8211	N°2 structure crosspieces w=800mm	2
VC3080	Cable container 300x800mm (wxd) K	1

ArTu K Series dim. 1800x2280x700 (2031x2904x837) mm (external hwxwd) IP65 with Emax E1, T5 and XT3, 1600A omnibus busbars and vertical 1250A branches - Icw 50kA

Code	Description	Q.ty
AD1014	Lateral side-by-side Kit, K	4
AD1069	N°4 connect. coupling busbars from 1250/1600A to 800A	3
BA1250	Busbar In=1250A	4
BA1600	Busbar In=1600A	12
KE3215	Kit E1, E2, E3 vert. fixed without segreg. K	3
KX3411	XT3 Kit 3/4P horiz. fixed without segreg. K	4
KT5411	T5 Kit horiz. fixed 300x400mm (hwx) K	4
LF1880	N°2 side panels 1800x800mm (hxd) K	1
PB1601	Linear busbar holder In=1600A (75 kA)	10
PC2400	Blind panel 200x400mm (hwx) K	8
PC2600	Blind panel 200x600mm (hwx) M, K	5
PC6600	Blind panel 600x600mm (hwx) M, K	1
PO1831	Blind door 1800x300mm (hwx) L, M int.	1
PO1833	Blind door 1800x300mm (hwx) K ext.	1
PS4720	4-instrument panel 72x72 200x600mm (hwx)M, K	1
PV1841	Glass door 1800x400mm (hwx) K	2
PV1861	Glass door 1800x600mm (hwx) K	2
RF1830	Cable container rear panel 1800x300mm (hwx) K	1
RF1840	Rear panel 1800x400mm (hwx) K	2
RF1860	Rear panel 1800x600mm (hwx) K	2
SK1800	N°4 ArTu K uprights h=1800mm	5
SK1803	N°2 funct. frames h=1800mm open K	4
SK4080	ArTu K Base/Top/Base strip 400x800mm (wxd)	2
SK6080	ArTu K Base/Top/Base strip 600x800mm (wxd)	2
TV6221	N°2 funct. frame struct. crosspieces w=600mm	2
TV8001	N°2 Open frame struct. crosspieces d=800mm	2
TV8011	N°2 structure crosspieces d=800mm	2
TV8211	N°2 structure crosspieces w=800mm	2
VC3080	Cable container 300x800mm (wxd) K	1

ArTu K Modular Structures

Examples of configurations

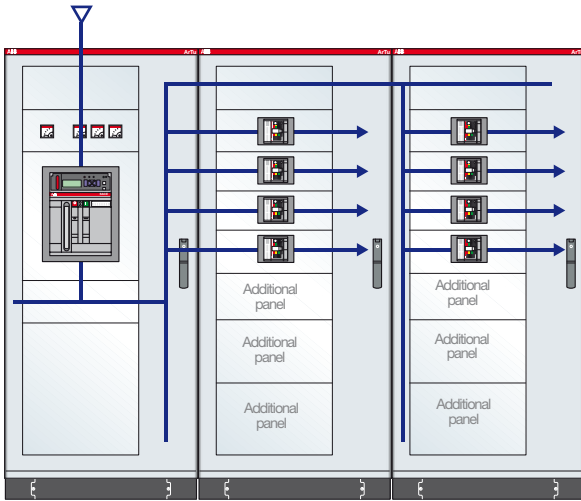

ArTu K Series dim. 1800x2400x700 (2031x2784x837) mm (external hxwxh) IP65 with Emax E1, T4 and T1, 1600A omnibus busbars and vertical 1250A branches - Icw 50kA

Code	Description	Q.ty
AD1014	Lateral side-by-side kit, K	2
AD1069	N°4 connect. coupling busbars from 1250/1600A to 800A	3
BA1250	Busbar In=1250A	5
BA1600	Busbar In=1600A	11
KE3215	Kit E1, E2, E3 vert. fixed without segreg. K	1
KT1111	Kit T1 3/4P horiz. fixed without segreg. K	2
KT4111	T4 Kit hor. fixed+access.200x600mm (hxw) K	6
LF1880	N°2 side panels 1800x800mm (hxd) K	1
PB1601	Linear busbar holder In=1600A (75 kA)	12
PC2600	Blind panel 200x600mm (hxw) M, K	6
PC3600	Blind panel 300x600mm (hxw) M, K	4
PC6600	Blind panel 600x600mm (hxw) M, K	1
PS4720	4-instrument panel 72x72 200x600mm (hxw)M, K	1
PV1881	Glass door 1800x800mm (hxw) K	3
RF1880	Rear panel 1800x800mm (hxw) K	3
SK1800	N°4 ArTu K uprights h=1800mm	3
SK1880	Open frame int. cable cont. rear assembly h=1800mm	1
SK8080	ArTu K Base/Top/Base strip 800x800mm (wxd)	3
TV6221	N°2 funct. frame struct. crosspieces w=600mm	1
TV8001	N°2 open frame struct. crosspieces d=800mm	2
TV8011	N°2 structure crosspieces d=800mm	1
TV8211	N°2 structure crosspieces w=800mm	1
VC1823	Int. reduced cable cont.1800x200mm (hxw) K	3

ArTu K Series dim. 1800x2400x700 (2031x2784x837) mm (external hxwxh) IP65 with Emax E1, XT4 and XT1, 1600A omnibus busbars and vertical 1250A branches - Icw 50kA

Code	Description	Q.ty
AD1014	Lateral side-by-side kit, K	2
AD1069	N°4 connect. coupling busbars from 1250/1600A to 800A	3
BA1250	Busbar In=1250A	5
BA1600	Busbar In=1600A	11
KE3215	Kit E1, E2, E3 vert. fixed without segreg. K	1
KX1611	Kit XT1 3/4P horiz. fixed without segreg. K	2
KX4611	XT4 Kit hor. fixed+access.200x600mm (hxw) K	6
LF1880	N°2 side panels 1800x800mm (hxd) K	1
PB1601	Linear busbar holder In=1600A (75 kA)	12
PC2600	Blind panel 200x600mm (hxw) M, K	6
PC3600	Blind panel 300x600mm (hxw) M, K	4
PC6600	Blind panel 600x600mm (hxw) M, K	1
PS4720	4-instrument panel 72x72 200x600mm (hxw)M, K	1
PV1881	Glass door 1800x800mm (hxw) K	3
RF1880	Rear panel 1800x800mm (hxw) K	3
SK1800	N°4 ArTu K uprights h=1800mm	3
SK1880	Open frame int. cable cont. rear assembly h=1800mm	1
SK8080	ArTu K Base/Top/Base strip 800x800mm (wxd)	3
TV6221	N°2 funct. frame struct. crosspieces w=600mm	1
TV8001	N°2 open frame struct. crosspieces d=800mm	2
TV8011	N°2 structure crosspieces d=800mm	1
TV8211	N°2 structure crosspieces w=800mm	1
VC1823	Int. reduced cable cont.1800x200mm (hxw) K	3

ArTu K Modular Structures

Examples of configurations

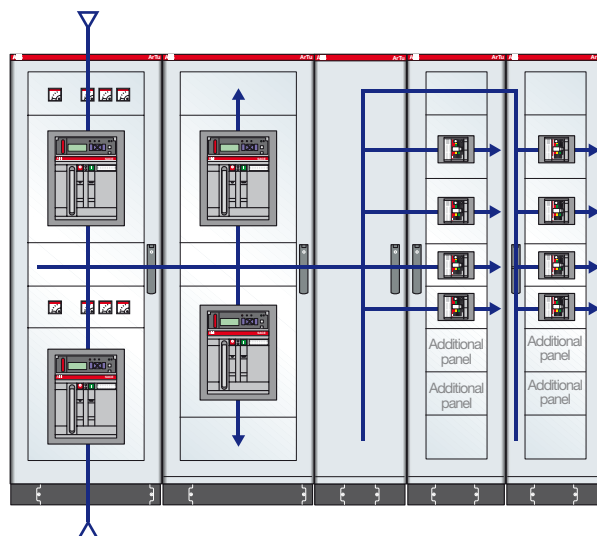

ArTu K Series dim. 1800x2280x700 (2031x2900x837) mm (external hwxwd) IP65 with Emax E2, T5 and T3, 3200A omnibus busbars and vertical 1600A branches - Icw 65kA

Code	Description	Q.ty
AD1014	Lateral side-by-side Kit, K	4
AD1073	N°4 busbar section T-couplings 3200A	1
AD1078	N°4 connect. coupling busbars from 3200A to 1600/1250A	1
BA1600	Busbar In=1600A	4
BA2000	Busbar In=2000A	20
KE3215	Kit E1, E2, E3 vert. fixed without segreg. K	4
KT3419	T3 Kit 3/4P horiz. fixed without segreg. K	3
KT5411	T5 Kit horiz. fixed 300x400mm (hwx) K	4
LF1880	N°2 side panels 1800x800mm (hxd) K	1
PB1601	Linear busbar holder In=1600A (75 kA)	6
PB3201	Linear busbar holder In=3200A (75 kA)	12
PC2400	Blind panel 200x400mm (hwx) K	8
PC2600	Blind panel 200x600mm (hwx) M, K	5
PO1831	Blind door 1800x300mm (hwx) L, M int.	1
PO1833	Blind door 1800x300mm (hwx) K ext.	1
PS4720	4-instrument panel 72x72 200x600mm (hwx) M, K	1
PV1841	Glass door 1800x400mm (hwx) K	2
PV1861	Glass door 1800x600mm (hwx) K	2
RF1830	Cable container rear panel 1800x300mm (hwx) K	1
RF1840	Rear panel 1800x400mm (hwx) K	2
RF1860	Rear panel 1800x600mm (hwx) K	2
SK1800	N°4 ArTu K uprights h=1800mm	5
SK1803	N°2 funct. frames h=1800mm open K	4
SK1880	Open frame int. cable cont. rear assembly h=1800mm	1
SK4080	ArTu K Base/Top/Base strip 400x800mm (wxd)	2
SK6080	ArTu K Base/Top/Base strip 600x800mm (wxd)	2
TV6221	N°2 funct. frame struct. crosspieces w=600mm	2
TV8001	N°2 open frame struct. crosspieces d=800mm	3
TV8011	N°2 structure crosspieces d=800mm	2
TV8101	N°2 int./ext. cable cont. crosspieces d=800mm	3
TV8211	N°2 structure crosspieces w=800mm	2
VC3080	Cable container 300x800mm (wxd) K	2

ArTu K Series dim. 1800x2280x700 (2031x2900x837) mm (external hwxwd) IP65 with Emax E2, T5 and XT3, 3200A omnibus busbars and vertical 1600A branches - Icw 65kA

Code	Description	Q.ty
AD1014	Lateral side-by-side Kit, K	4
AD1073	N°4 busbar section T-couplings 3200A	1
AD1078	N°4 connect. coupling busbars from 3200A to 1600/1250A	1
BA1600	Busbar In=1600A	4
BA2000	Busbar In=2000A	20
KE3215	Kit E1, E2, E3 vert. fixed without segreg. K	4
KX3411	XT3 Kit 3/4P horiz. fixed without segreg. K	3
KT5411	T5 Kit horiz. fixed 300x400mm (hwx) K	4
LF1880	N°2 side panels 1800x800mm (hxd) K	1
PB1601	Linear busbar holder In=1600A (75 kA)	6
PB3201	Linear busbar holder In=3200A (75 kA)	12
PC2400	Blind panel 200x400mm (hwx) K	8
PC2600	Blind panel 200x600mm (hwx) M, K	5
PO1831	Blind door 1800x300mm (hwx) L, M int.	1
PO1833	Blind door 1800x300mm (hwx) K ext.	1
PS4720	4-instrument panel 72x72 200x600mm (hwx) M, K	1
PV1841	Glass door 1800x400mm (hwx) K	2
PV1861	Glass door 1800x600mm (hwx) K	2
RF1830	Cable container rear panel 1800x300mm (hwx) K	1
RF1840	Rear panel 1800x400mm (hwx) K	2
RF1860	Rear panel 1800x600mm (hwx) K	2
SK1800	N°4 ArTu K uprights h=1800mm	5
SK1803	N°2 funct. frames h=1800mm open K	4
SK1880	Open frame int. cable cont. rear assembly h=1800mm	1
SK4080	ArTu K Base/Top/Base strip 400x800mm (wxd)	2
SK6080	ArTu K Base/Top/Base strip 600x800mm (wxd)	2
TV6221	N°2 funct. frame struct. crosspieces w=600mm	2
TV8001	N°2 open frame struct. crosspieces d=800mm	3
TV8011	N°2 structure crosspieces d=800mm	2
TV8101	N°2 int./ext. cable cont. crosspieces d=800mm	3
TV8211	N°2 structure crosspieces w=800mm	2
VC3080	Cable container 300x800mm (wxd) K	2

ArTu K Modular Structures

Examples of configurations

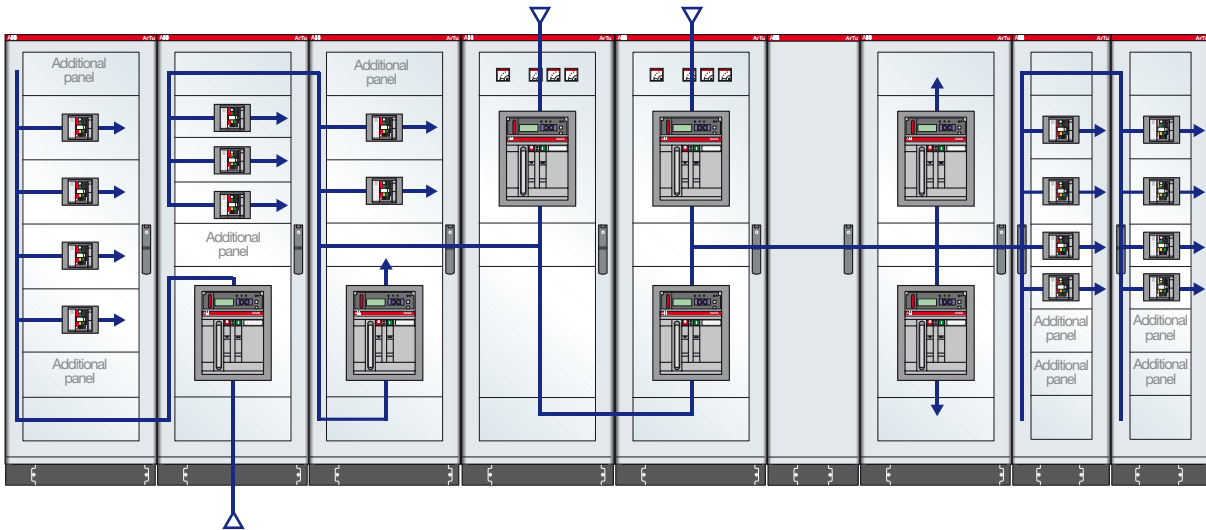

ArTu K Series dim. 1800x4680x900 (2031x5804x1037) mm.
(external hxwxd) IP65 with Emax E3, T5 and T33200A omni-
bus busbars and vertical 1600A branches - Icw 50kA

ArTu K Series dim. 1800x4680x900 (2031x5804x1037) mm.
(external hxwxd) IP65 with Emax E3, T5 and XT3 3200A omni-
bus busbars and vertical 1600A branches - Icw 50kA

Code	Description	Q.ty
AD1014	Lateral side-by-side Kit, K	8
BP1600	N°2 busbar holders x cross-section 10mm	9
BP3200	N°2 busbar holders 3 phase busbars cross-sect. 10mm	6
BR1600	N°2 busbars cross-section100x10mm w=1750mm	29
KE3215	Kit E1, E2, E3 vert. fixed without segreg. K	7
KT3119	T3 Kit 3/4P horiz. fixed without segreg. K	3
KT3419	T3 Kit 3/4P horiz. fixed without segreg. K	4
KT5111	Hor. fixed T5 Kit+accessories 300x600mm (hxw) K	6
KT5411	T5 Kit horiz. fixed 300x400mm (hxw) K	4
LF1810	N°2 side panels 1800x1000mm (hxd) K	1
PC2400	Blind panel 200x400mm (hxw) K	8
PC2600	Blind panel 200x600mm (hxw) M, K	16
PC6600	Blind panel 600x600mm (hxw) M, K	1
PO1831	Blind door 1800x300mm (hxw) L, M int.	1
PO1833	Blind door 1800x300mm (hxw) K ext.	1
PS4720	4-instrument panel 72x72 200x600mm (hxw) M, K	2
PV1841	Glass door 1800x400mm (hxw) K	2
PV1861	Glass door 1800x600mm (hxw) K	6
RF1830	Cable container rear panel 1800x300mm (hxw) K	1
RF1840	Rear panel 1800x400mm (hxw) K	2
RF1860	Rear panel 1800x600mm (hxw) K	6
SK1800	N°4 ArTu K uprights h=1800mm	9
SK1803	N°2 funct. frames h=1800mm open K	8
SK4010	ArTu K Base/Top/Base strip 390x1000mm (wxd)	2
SK6010	ArTu K Base/Top/Base strip 600x1000mm (wxd)	6
TR1201	N°2 hor. struct. busbar crosspieces d=1000mm	6
TV1001	N°2 open frame struct. crosspieces d=1000mm	15
TV1211	N°2 structure crosspieces d=1000mm	6
VC3010	ArTu K Base/Top/Base strip 300x1000mm (wxd)	1

Code	Description	Q.ty
AD1014	Lateral side-by-side Kit, K	8
BP1600	N°2 busbar holders x cross-section 10mm	9
BP3200	N°2 busbar holders 3 phase busbars cross-sect. 10mm	6
BR1600	N°2 busbars cross-section100x10mm w=1750mm	29
KE3215	Kit E1, E2, E3 vert. fixed without segreg. K	7
KX3611	XT3 Kit 3/4P horiz. fixed without segreg. K	3
KX3411	XT3 Kit 3/4P horiz. fixed without segreg. K	4
KT5111	Hor. fixed T5 Kit+accessories 300x600mm (hxw) K	6
KT5411	T5 Kit horiz. fixed 300x400mm (hxw) K	4
LF1810	N°2 side panels 1800x1000mm (hxd) K	1
PC2400	Blind panel 200x400mm (hxw) K	8
PC2600	Blind panel 200x600mm (hxw) M, K	16
PC6600	Blind panel 600x600mm (hxw) M, K	1
PO1831	Blind door 1800x300mm (hxw) L, M int.	1
PO1833	Blind door 1800x300mm (hxw) K ext.	1
PS4720	4-instrument panel 72x72 200x600mm (hxw) M, K	2
PV1841	Glass door 1800x400mm (hxw) K	2
PV1861	Glass door 1800x600mm (hxw) K	6
RF1830	Cable container rear panel 1800x300mm (hxw) K	1
RF1840	Rear panel 1800x400mm (hxw) K	2
RF1860	Rear panel 1800x600mm (hxw) K	6
SK1800	N°4 ArTu K uprights h=1800mm	9
SK1803	N°2 funct. frames h=1800mm open K	8
SK4010	ArTu K Base/Top/Base strip 390x1000mm (wxd)	2
SK6010	ArTu K Base/Top/Base strip 600x1000mm (wxd)	6
TR1201	N°2 hor. struct. busbar crosspieces d=1000mm	6
TV1001	N°2 open frame struct. crosspieces d=1000mm	15
TV1211	N°2 structure crosspieces d=1000mm	6
VC3010	ArTu K Base/Top/Base strip 300x1000mm (wxd)	1



Index

Gemini

Compliance with Standards and technical characteristics	6/2
IP degree of protection.....	6/4
IK degree of resistance to impacts.....	6/5
Double insulation.....	6/6
Self-extinguishing tests	6/6
Resistance to chemical agents	6/7
Disposal instructions	6/8

ArTu distribution switchgear

Mechanical and electrical characteristics	6/10
Declaration of conformity	6/12
Dissipated power.....	6/13
Handling	6/18
Electrical continuity	6/20
Equipotential conductors	6/21
Degrees of protection.....	6/22
IK mechanical resistance to impact	6/24

Busbars with shaped section and flat busbars

Mechanical and electrical characteristics	6/25
---	------

Busbars with shaped section

Characteristics of the components	6/26
---	------

Flat busbars

Characteristics of the components	6/28
---	------

Unifix cabling system

Examples of connections - Unifix H.....	6/30
---	------

Examples of connections - Unifix L.....	6/31
---	------

Segregations

Examples of ArTu segregation.....	6/32
-----------------------------------	------

Gemini switchboards

Compliance with Standards and technical characteristics

Reference Standards

The IEC 62208 Standard (“Empty enclosures for assembled protection and operating apparatus for low voltage. General Prescriptions”) has implemented the EN 50298 Standard reissued in EN 62208 internationally, and is the reference for the Gemini switchboards: as its subject, it has formulation of the definitions, classifications, characteristics and testing prescriptions for enclosures destined for uses in accordance with the EN 60439 Standards and the new IEC 61439-1-2 Standard as part of protection and operating apparatus (switchboards), whose rated voltage does not exceed 1000 V in alternating current for frequencies up to 1000 Hz or 1500 V in direct current and suitable for general use in both indoor and outdoor applications.

The Standard refers to empty enclosures, before the user installs protection and operating apparatus.

The Standard does not apply to enclosures which, due to their construction and functional characteristics, are subject to other prescriptions (e.g. enclosures for domestic and similar installations). In this case, the IEC 60670 – CEI 23-48 Standards are the reference (“Enclosures for apparatus for fixed electrical installations for domestic and similar uses. Part 1: general prescriptions”) and CEI 23-49 (“Enclosures for apparatus for fixed electrical installations for domestic and similar uses. Part 2: special prescriptions for enclosures destined to contain protection devices and apparatus which dissipate a power that is not negligible”).

On the basis of what is indicated by ABB SACE in the table of technical characteristics, if, necessary, the installer must certify conformity with the CEI 23-51 (“Prescriptions for constructing, checking and testing distribution switchboards for fixed installations for domestic and similar use”) or EN 60439-1/ IEC 61439-1-2 Standards.

Gemini switchboards

Compliance with Standards and technical characteristics

Table of Gemini switchboards' technical characteristics

Size 1	2	3	4	5	6	
Gemini with transparent door	1SL0211A00	1SL0212A00	1SL0213A00	1SL0214A00	1SL0215A00	1SL0216A00
Gemini with opaque door	1SL0201A00	1SL0202A00	1SL0203A00	1SL0204A00	1SL0205A00	1SL0206A00
External dimensions WxHxD (mm)	335x400x210	460x550x260	460x700x260	590x700x260	590x855x360	840x1005x360
Internal dimensions WxHxD (mm)	250x300x180	375x450x230	375x600x230	500x600x230	500x750x330	750x900x330
IP degree	IP66	IP66	IP66	IP66	IP66	IP66
Double isolation	yes	yes	yes	yes	yes	yes
IK degree	10	10	10	10	10	10
GWT (°C)	750	750	750	750	750	750
Operating temperature	-25° C ... +100° C	-25° C ... +100° C	-25° C ... +100° C	-25° C ... +100° C	-25° C ... +100° C	-25° C ... +100° C
No. of DIN modules	24 (12x2)	54 (18x3)	72 (18x4)	96 (24x4)	120 (24x5)	216 (36x6)
No. of vertical modules (H=150 mm)	2	3	4	4	5	6
Material	Thermoplastic	Thermoplastic	Thermoplastic	Thermoplastic	Thermoplastic	Thermoplastic
Color	Grey RAL7035	Grey RAL7035	Grey RAL7035	Grey RAL7035	Grey RAL7035	Grey RAL7035
Fast wiring system	Unifix L	Unifix L	Unifix L	Unifix L	Unifix L	Unifix L
No. of locks	2	2	2	2	3	3
Rated frequency	50-60 Hz	50-60 Hz	50-60 Hz	50-60 Hz	50-60 Hz	50-60 Hz
STANDARD CEI 23-51⁽¹⁾						
- Maximum dissipation power ⁽²⁾	45 W	72 W	85 W	102 W	156 W	248 W
STANDARD CEI EN 60439-1 – EN61439-1-2						
Over-temperature (par. 8.2.1)⁽³⁾						
- Max. dispersible power with over-temperature of 25 °C	40 W	65 W	77 W	91 W	133 W	205 W
- Max. dispersible power with over-temperature of 30 °C	45 W	72 W	85 W	102 W	156 W	248 W
- Max. dispersible power with over-temperature of 35 °C	52 W	85 W	100 W	121 W	187 W	299 W
- Max. dispersible power with over-temperature of 40 °C	62 W	100 W	118 W	143 W	221 W	355 W
Impulse withstand (par. 8.2.2)						
- Rated service voltage	≤ 690 V	≤ 690 V	≤ 690 V	≤ 690 V	≤ 690 V	≤ 690 V
- Rated insulation voltage AC	≤ 1000 V	≤ 1000 V	≤ 1000 V	≤ 1000 V	≤ 1000 V	≤ 1000 V
- Rated insulation voltage DC	≤ 1500 V	≤ 1500 V	≤ 1500 V	≤ 1500 V	≤ 1500 V	≤ 1500 V
- Rated impulse withstand voltage	8 kV	8 kV	8 kV	8 kV	8 kV	8 kV

(1) Limits of Applicability of the CEI 23-51 Standard

The Standard is only applicable if the cabled switchboard fulfils all the following conditions:

- fixed installation with average ambient temperature up to 25 °C, occasionally up to 35 °C;
- alternating current with rated voltage up to 440 V;
- rated incoming current up to 125 A;
- rated prospective short-circuit current up to 10 kA or protection using current-limiting devices with limited current up to 15 kA in correspondence with their rated breaking capacity.

⁽²⁾ The data on the maximum dissipated power were taken following the indications in the CEI 23-49 Standard, with a temperature difference of Dt=30 °C.

(3) Note to paragraph 8.2.1 of Standard CEI EN 60439-1

The table gives the thermal dissipation values of Gemini switchboards when they are wall-mounted. The dispersible power figures (in Watts) vary according to the overtemperature allowed in the accessible parts of the switchboard and must be compared with the total amount of power dissipated by all the components installed inside the switchboard taking into due account the factor of contemporaneity.

Gemini switchboards

IP degree of protection

As indicated in the following table, the IP degree of protection is expressed by two characteristic numbers depending on the behavior of the product to which it refers according to the prescriptions of CEI 70-1 and IEC 529 Standards.

With IP66 degree of protection, Gemini switchboards are totally protected against the penetration of dusts and sprays of seawater.

1st Number: protection against the penetration of solid bodies

0	No protection
1	Protection against the penetration of solid bodies with a diameter of over 50 mm
2	Protection against the penetration of solid bodies with a diameter of over 12 mm or a length of over 80 mm
3	Protection against the penetration of solid bodies with a diameter or thickness of over 2.5 mm
4	Protection against the penetration of solid bodies with a diameter or thickness of over 1.0 mm
5	Protection against the penetration of dusts
6	Total protection against the penetration of dusts

1st number defined by Standards CEI 70-1 – IEC 60529

2nd Number: protection against the penetration of water

0	No protection
1	Protection against the penetration of drops of water falling vertically
2	Protection against the penetration of drops of water falling at an angle of up to 15° from vertical
3	Protection against the penetration of drops of water falling at an angle of up to 60° from vertical
4	Protection against the penetration of splashes of water from all directions
5	Protection against the penetration of water sprayed by a hose from all directions
6	Protection against the penetration of sea water
7	Protection against the penetration of water during temporary immersion
8	Protection against the penetration of water during continual immersion

2nd number defined by Standards CEI 70-1 - IEC 60529

Gemini switchboards

IK degree of resistance to impacts

IK degree of resistance to impacts

The IK degree is expressed in Joules in compliance with Standard IEC 62262.

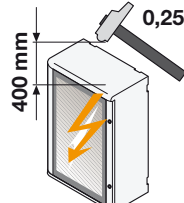
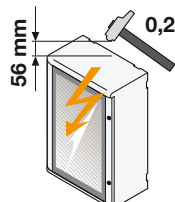
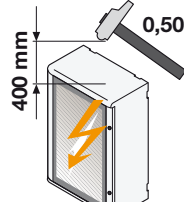
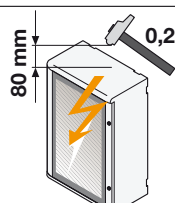
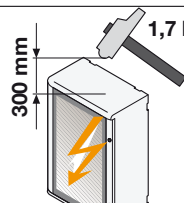
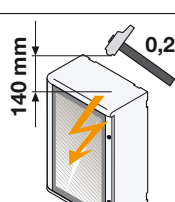
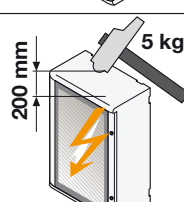
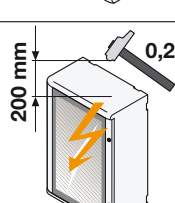
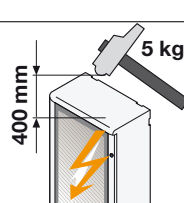
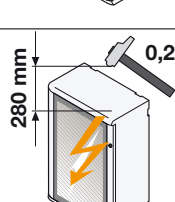
IK 0	 <p>No protection against impacts</p>	IK 06	 <p>Resistance to impacts with impact energy up to 1,00 J</p>
IK 01	 <p>Resistance to impacts with impact energy up to 0,150 J</p>	IK 07	 <p>Resistance to impacts with impact energy up to 2,00 J</p>
IK 02	 <p>Resistance to impacts with impact energy up to 0,200 J</p>	IK 08	 <p>Resistance to impacts with impact energy up to 5,00 J</p>
IK 03	 <p>Resistance to impacts with impact energy up to 0,350 J</p>	IK 09	 <p>Resistance to impacts with impact energy up to 10,00 J</p>
IK 04	 <p>Resistance to impacts with impact energy up to 0,500 J</p>	IK 10	 <p>Gemini Resistance to impacts with impact energy up to 20,00 J</p>
IK 05	 <p>Resistance to impacts with impact energy up to 0,700 J</p>		

6

1SLC650506F6901

Gemini switchboards

Double insulation and self-extinguishing tests

Double insulation

Double insulation guarantees that Gemini is protected against indirect contacts on condition that the manufacturer's instructions are observed when carrying out mounting and wiring operations on the switchboard and that the appropriate accessories are used (e.g. screw-cover caps).

Double insulation is indicated by the graphic symbol

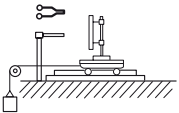

Self-extinguishing tests

Test text	Equipment required	Compliance with Standards	Purpose of the test	Test results	Test conditions Heat source	Length of test	Character. elements
GLOW-WIRE TEST  1SLC80043F0001		IEC 695-2-1 CEI 50-11	To assess the danger of fire by simulating thermal stresses produced by heat sources or by ignition (e.g. glowing elements, resistances overloaded for short intervals)	If a flame is generated, it must go out within 30 seconds of removing the glow wire. The test is conducted at temperatures of: - 650 °C - 750 °C - 850 °C - 960 °C	Glow wire ø 4 mm	30 sec.	Assessment of the time it takes for the flame to go out

Gemini switchboards

Resistance to chemical agents

Resistance to chemical agents

The behavior of Gemini switchboards in the presence of chemical agents is indicated in the table with the symbols:

	High resistance	Limited resistance
Cold water	●	
Hot water	●	
Sulfuric acid 50%	●	
Hydrochloric acid 36%	●	
Acetic acid 60%	●	
Benzol		●
Gasoline		●
Acetone	●	
Ethyl alcohol	●	
Ammonia	●	
Dichlormethane		●
Diesel oil - naphtha		●
Mineral oils and greases	●	
Food oils and greases	●	
Perchloroethylene		●
Trichlorethene		●
Ethylether	●	
Toluene		●
Methanol	●	
Wine	●	
Fruit juices	●	
Laundry lye	●	
Detergents	●	

Gemini switchboards

Disposal instructions

Information about how to dispose of Gemini switchboards when they reach the end of their life

Instructions are given below about the procedures to adopt when disposing of Gemini switchboards at the end of their life cycle. The text is drafted in the form of a table referring to Standard CEI 308-1 "Information table concerning the end of life of electric and electronic products and a compilation guide", 2002-04, ed. 1, pamphlet number 308-1 6454.

Section I – Global product specification

Name Size	Type of product		Rated weight (kg)	External dimensions WxHxD (mm)
	With transparent door	With opaque door		
1	1SL0211A00	1SL0201A00	4,3	335x400x210
2	1SL0212A00	1SL0202A00	7,9	460x550x260
3	1SL0213A00	1SL0203A00	9,5	460x700x260
4	1SL0214A00	1SL0204A00	12,0	590x700x260
5	1SL0215A00	1SL0205A00	17,8	590x855x360
6	1SL0216A00	1SL0206A00	21,1	840x1005x360

Section II – Global product table

General code: CER 17 02 03 plastic (more than 95% of the product's weight)

No. of the component part (P1, P2, etc.)	Diagram	Quantity % over total weight	Material description	Symbol	Dangerousness (Yes/No)	CER Code
P1/BOX		~ 80%	Polypropylene		No	17 02 03
P2/ROOF			Polypropylene		No	17 02 03
P3/DOOR		~ 20%	Polycarbonate		No	17 02 03
P4/ACCESSORIES		< 5%	Steel	-	No	17 04 05
P5/ACCESSORIES		< 5%	Brass	-	No	17 04 01

1SL0205017F0901

Gemini switchboards

Disposal instructions

Section III – Components to be removed from the product and sent for separate treatment

Refer to section II of the table for a description of the materials.

Notes for recovery and disposal

At the end of its life, after separating it from components, the product can be sent to be recovered.

The product is not biodegradable: do not dispose of it in the environment.

The product/waste product is assimilable as solid urban waste. It must be incinerated or disposed of in compliance with current EEC, national and local regulations. You are recommended to check all reutilization possibilities.

Other recommendations

The information in this table relates to the product in the condition it was supplied. Assembled parts coming from different supplies must be treated separately according to the reference specifications of the respective manufacturers.

Section IV – Safety instructions

Handling

No special instructions. Refer to the general regulations concerning hygiene on the workplace when using.

The product's main components contain mineral additives and coloring agents in concentrations that comply with current European Directives at the time this catalogue went to press: they do not contain substances classified as dangerous.

Transport

No special instructions.

Storage

No gas or harmful vapors are released during storage. Thermal decomposition in the event of fire or combustion may release dangerous products: if this should occur, specific means of protection must be used. In the event of fire, conventional fire extinguishing instruments are recommended (atomized water, foam, carbon dioxide, powder).

Empty packages are not contaminated by the product and can therefore be recycled or reused.

Utilization

No special instructions.

Other instructions

The information given in this section is based on current ABB SACE know-how and is aimed at describing the product only for environmental, health and safety purposes. It must not, therefore, be considered as a guarantee of specific properties. ABB SACE assumes no responsibility for the behavior of buyers that do not comply with the information given in this table and for incorrect or improper usages of the product or usages that cannot reasonably be envisaged.

ArTu distribution switchgear

Mechanical and electrical characteristics

Conformity with the CEI EN 60439-1/IEC 61439-1-2 Standard

The ArTu switchboards have undergone the type tests foreseen by the CEI EN 60439-1 Standard and the new IEC 61439-1-2 Standard at the ABB type test laboratories. The results of these tests guarantee the performances of the ArTu switchboards and allow the end constructor of the switchboard using ABB SACE

metal structures, air, moulded-case and modular circuit-breakers, not to carry out further type tests, respecting the selection criteria and the assembly instructions of the various components. These results, given below, can be referred to for drawing up the declaration of conformity of the electric switchboard.

Overtemperature (Ref. par. 8.2.1. of the Standard)

In the tables on page 5/5 and following, the thermal dissipation values are indicated, referring to all the dimensions of the ArTu switchboards and to the type of installation, deriving from the type tests carried out. The dissipated power data (in Watts) are according to the admissible overtemperature inside the switchboard in the upper part, and must be compared with the sum of the powers dissipated by all the components installed inside the switchboard (taking appropriately into account the factor of contemporaneity).

Dielectric properties (Ref. par. 8.2.2 of the Standard)

	Wall-mounted ArTu L D=200mm	Floor-standing ArTu L D=250mm	Wall-mounted ArTu M D=150/200mm	Floor-standing ArTu M ArTu K D=250mm	ArTu K
Rated service voltage:	up to 690V AC	up to 690V AC	up to 690V AC	up to 690V AC	up to 1000V AC
Rated insulation voltage:	up to 1000V AC	up to 1000V AC	up to 1000V AC	up to 1000V AC	up to 1000V AC
Rated impulse withstand voltage:	6 kV	8 kV	6 kV	8 kV	8 kV

Short-circuit withstand current (Ref. par. 8.2.3 of the Standard)

	Wall-mounted ArTu L D=200mm	Floor-mounted ArTu L D=250mm	Wall-mounted ArTu M D=150/200mm	Floor-mounted ArTu M ArTu K D=250mm	ArTu K
Rated short-time short-circuit current: phase-phase	25 kA (1s)	35 kA (1s)	25 kA (1s)	35 kA (1s)	105kA (1s) 50kA(3s)
phase-neutral	9 kA (1s)	21 kA (1s)	9kA (1s)	21 kA (1s)	60 kA (1s)
Rated max. peak short-circuit current	52.5kA	73kA	52.5kA	73kA	254kA

Efficiency of the protection circuit (Ref. par. 8.2.4 of the Standard)

	Wall-mounted ArTu L D=200mm	Floor-mounted ArTu L D=250mm	Wall-mounted ArTu M D=150/200mm	Floor-mounted ArTu M ArTu K D=250mm	ArTu K
(Ref. par. 8.2.4.1):	Following the assembly indications of the metal components, the effective electrical continuity between the exposed conductive parts is verified, with negligible resistance values.				
(Ref. par. 8.2.4.2):	Protection circuit short-circuit withstand current: phase-earthing busbar				
	9 kA (1s)	21 kA (1s)	9 kA (1s)	21 kA (1s)	60 kA (1s)

Insulation distances (Ref. par. 8.2.5 of the Standard)

The insulation distances are guaranteed by following the ABB SACE metalwork structure and circuit-breaker assembly and mounting instructions.

Mechanical operation (Ref. par. 8.2.6 of the Standard)

Mechanical operation is verified by following the assembly and mounting instructions for the ABB SACE metalwork structures and circuit-breakers.

Degree of protection (Ref. par. 8.2.7 of the Standard) According to CEI EN 60529 (CEI 70-1 publication IEC 529)

	Wall-mounted ArTu L D=200mm	Floor-mounted ArTu L D=250mm	Wall-mounted ArTu M D=150/200mm	Floor-mounted ArTu M ArTu K D=250mm	ArTu K
Without door	IP31	IP31	-	IP 31	IP31
With door/without door and ventilated side panels	-	-	-	-	IP41
With door	IP43	IP43	IP 65	IP 65	IP 65

ArTu distribution switchgear

Mechanical and electrical characteristics

Mechanical characteristics

Material

ArTu L structure	12/10mm thick pickled steel sheet
ArTu M structure	15/10mm thick steel sheet (floor-mounted) / 15/10mm hot galvanised sheet (wall-mounted)
ArTu K structure	15/10mm thick steel sheet
Panels	12/15/10mm thick steel sheet
Doors	15/10mm hot galvanised steel sheet. 4mm thick glass tempered from inside
Plates	hot galvanised steel sheet, thickness: Plates 20/25/10mm

Painting

Structure colour	Grey orange-peel RAL 7035
Base strip colour	Grey orange-peel RAL 7012
Standard cycle	Sheet washing Phosphating with iron salt base Drying in tunnel at 100°C External and internal painting with electrostatic application of thermosetting powder enamel with epoxy polyester binders. Grey orange-peel RAL 7035 colour, total thickness: 60/70 micron. Polymerisation in oven at 180°C.
Paint characteristics	Binder: epoxy polyester Specific gravity: 1.61 g/cm ³ Theoretical coverage: 10.4 m ² /kg with average film thickness 60 micron Melting point: 85-95°C (Kofler bench method) Granulometry: standard distribution between 5 and 100 micron with average size of the particles between 30 and 40 micron. Hardening: 12 min. at 190 °C (temperature of object) Hardness: 1H - 2H DIN 53152 bending elasticity: unaltered on 1/4" spindle DIN 53151 reticular adherence: GT O (100%) Erichem elasticity: SEN DIN 53156: > 6mm Gardner resistance to impact: 25 Kg. x cm.

Tests carried out on degreased and phosphated sheets with film thickness of 60/70 micron.
The painting has passed the resistance tests to saline fog (193 hours).

Ambient characteristics

Type of installation	indoors
Installation conditions	Wall / Floor-mounted
Service climate (t° / r.h. %)	constant 23 °C/83% - 40 °C/93% variable 23 °C/98% - 40 °C/98%
Ambient temperature limits	operating -5 °C +40 °C storage -25 °C +55 °C

ArTu distribution switchgear

Declaration of conformity

ABB SACE declaration of conformity

ArTu switchgear with the following rated characteristics:

Rated service voltage	up to 690V / up to 1000V for ArTu K	
Rated insulation voltage	up to 1000V	
Rated current / I_{cw}	ArTu L wall-mounted	up to 250 A / 25 kA
	ArTu L floor-mounted	up to 800 A / 35 kA
	ArTu K	up to 4000 A / up to 105 kA
	ArTu M floor-mounted and K D=250mm	up to 630 A / 35 kA
	ArTu M D=150/200mm	up to 250 A / 25 kA
Degree of protection	ArTu L	IP31 (without door), IP 43 (with door)
	ArTu K	IP31 (without door), IP41 (with door and side ventilation), IP65 (with door)
	ArTu M D=250mm	IP31 (without door), IP65 (with door)
	ArTu M D=150/200mm	IP 65 (with door)

when correctly selected and assembled, as per the indications given in this catalogue and in the instruction manual, allow construction of switchgear complying with the IEC 60439-1/IEC 61439-1-2 Standard, on the basis of what is foreseen by the Low Voltage Directive of the European Community (Directive 73/23/EEC, Law 791/1977).

The above is valid if the switchgear is designed and constructed:

- selecting the materials according to the performances indicated in the ABB catalogues;
- sizing the conductors according to the prescriptions of the IEC 60439-1 and CEI 64-8 Standards;
- carrying out the individual tests foreseen under the IEC 60439-1 Standard successfully.

Technical information

Information regarding the methods for disposal and end of product life







ABB SACE has carried out a study on the end of product life. Evaluation is made by means of applying the LCA (Life Cycle Assessment) method according to ISO 14040 - 1997 and in conformity with the requirements established by the SEMC in the document ISO TR 14025 TYPE III Environmental Declarations (MSR 1999:2 – "Guidelines for the Environmental Product Declaration").

The study was carried out taking into consideration the disposal and recycling processes of the main materials making up a typical switchboard.

Starting from the basic list, the facility of dismantling and separating each piece, as well as recyclability of the materials was considered, and the product results as being almost completely recyclable.

Again starting from the basic list reduced to the significant components, the end of life of each of these was evaluated.

The flows of recyclable materials, materials to be recovered (or for incineration), given in the Table resulted. According to the hypotheses made, no material should end up directly in the dump.

Substance	Destination	
Aluminium waste	Recycling	
Copper waste	Recycling	
Polyurethane gaskets	Incineration	
Glass fibres	Recycling	
Glass waste	Recycling	
Paper/cardboard	Recycling	
Plastic Insulators	Recycling	
Sheet metal waste	Recycling	

ArTu distribution switchgear

Dissipated power

ArTu IP 31 switchgear

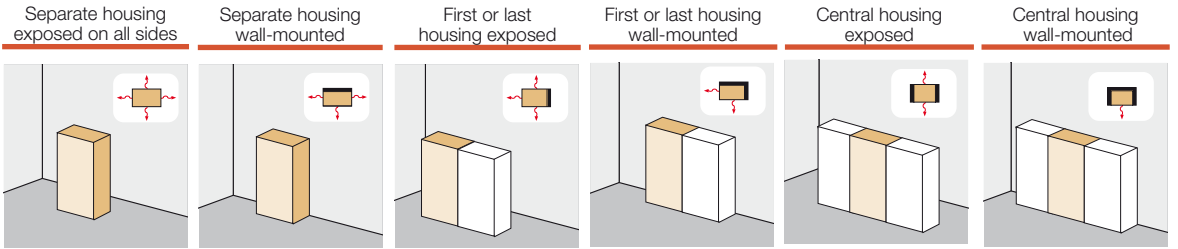

	Max. dissipated power (W)				Max. dissipated power (W)				Max. dissipated power (W)				Max. dissipated power (W)				Max. dissipated power (W)				Max. dissipated power (W)							
	Overtemperature				Overtemperature				Overtemperature				Overtemperature				Overtemperature				Overtemperature							
	25° C	30° C	35° C	40° C	25° C	30° C	35° C	40° C	25° C	30° C	35° C	40° C	25° C	30° C	35° C	40° C	25° C	30° C	35° C	40° C	25° C	30° C	35° C	40° C	25° C	30° C	35° C	40° C
ArTu L																												
SL0600					99	125	150	176					95	118	143	168					91	113	137	160				
SL0800					106	134	160	188					100	125	152	178					107	132	160	189				
SL1000					122	152	184	216					116	143	174	204					113	141	170	201				
SL1200					135	170	205	241					128	161	193	228					126	156	189	223				
SL1400	174	217	265	312	155	195	237	278	168	211	255	301	145	183	221	261	164	206	250	295	140	176	213	252				
SL1600	194	242	294	347	171	213	259	306	185	232	281	332	160	200	242	286	180	226	274	323	154	193	233	276				
SL1800	211	264	320	378	184	231	281	331	200	251	305	360	173	217	262	309	195	244	296	350	166	208	252	298				
SL2000	227	285	345	408	197	248	300	354	215	270	327	386	185	231	281	331	206	262	318	375	178	223	271	319				
SL1408	246	309	374	442	206	257	311	369	237	297	360	425	197	246	299	352	229	287	348	410	190	239	288	341				
SL1608	273	342	415	490	231	289	351	415	264	331	402	474	220	276	331	395	253	318	385	454	211	265	321	380				
SL1808	286	359	435	513	245	308	373	441	278	349	422	498	235	295	358	422	268	337	408	482	229	287	348	411				
SL2008	303	380	461	543	271	340	411	485	298	374	453	535	263	329	399	471	294	367	446	526	254	318	385	455				
ArTu M																												
SM 1462	179	225	272	313	159	199	241	285	172	216	261	309	149	186	226	267	168	210	255	301	143	180	218	257				
SM 1662	196	246	298	352	173	217	263	310	187	235	285	336	161	203	245	290	182	229	277	327	156	195	236	279				
SM 1682	248	311	377	445	218	274	331	391	241	303	367	433	206	259	313	370	238	298	361	427	201	252	306	361				
SM 1862	212	266	323	381	186	233	282	333	202	253	307	362	174	218	264	311	196	246	298	352	167	210	254	300				
SM 1882	270	339	410	484	236	296	358	423	261	328	397	469	223	279	338	399	257	322	391	461	217	272	330	389				
SM 2062	228	286	346	409	198	248	301	355	215	270	327	386	185	232	281	331	209	262	317	375	178	223	270	319				
SM 2082	291	365	442	521	252	316	383	453	280	351	425	502	238	299	362	427	275	345	418	494	232	291	353	417				
ArTu K H 1600mm																												
SK 6025	206	257	310	367	185	229	275	325	198	247	298	351	172	215	257	305	192	242	290	342	167	207	248	283				
SK 8025	260	322	391	460	230	286	345	406	252	315	380	448	216	273	325	385	250	310	373	442	212	265	320	376				
ArTu K H 1800mm																												
SK 6025	222	278	338	396	196	245	295	348	212	255	320	377	184	230	276	325	206	258	310	368	178	222	267	315				
SK 8025	280	350	423	500	247	310	370	438	271	340	410	485	233	290	350	415	270	335	405	476	228	285	342	404				
SK 4040	223	280	338	400	208	258	314	371	208	262	315	374	187	234	281	332	193	246	296	350	170	215	260	310				
SK 6040	285	357	433	511	259	324	393	464	268	336	407	481	237	297	359	424	255	320	387	457	223	279	338	400				
SK 8040	356	446	540	638	319	400	484	572	339	425	515	608	296	371	449	530	327	410	496	586	283	355	430	508				
SK 4050	257	322	389	460	242	301	366	433	237	298	359	425	216	270	324	383	217	276	332	393	194	245	297	353				
SK 6050	328	412	499	589	302	378	458	541	306	383	464	549	273	342	414	489	286	359	434	513	254	319	386	456				
SK 8050	390	489	592	699	367	461	558	659	374	469	568	671	339	425	514	607	365	458	554	654	321	403	488	577				
SK 4060	290	364	440	520	276	344	418	494	265	333	402	476	244	305	367	434	240	305	367	435	218	274	333	395				
SK 6060	371	466	564	666	344	432	523	617	343	430	521	616	309	387	469	553	316	397	481	568	285	358	434	512				
SK 8060	423	531	643	759	415	521	631	745	408	512	621	733	381	478	579	684	402	505	611	722	359	451	546	645				
SK 4080	371	461	560	668	349	440	535	622	329	410	495	588	300	377	457	539	297	370	455	536	273	343	415	491				
SK 6080	428	537	651	769	426	535	648	765	407	511	619	731	388	486	589	695	384	481	583	688	352	442	535	632				
SK 8080	489	614	743	877	478	599	726	857	463	581	703	830	450	564	683	807	454	570	690	815	434	544	659	778				
SK 4010	445	553	672	802	419	528	642	746	395	492	594	706	360	452	548	647	356	444	546	643	328	412	498	589				
SK 6010	514	644	781	923	511	642	778	918	488	613	743	877	466	583	707	834	461	577	700	826	422	530	642	758				
SK 8010	587	737	892	1052	574	719	871	1028	556	697	844	996	540	677	820	968	545	684	828	978	521	653	791	934				
ArTu K H 2000mm																												
SK 6025	240	298	358	424	208	260	313	370	225	282	340	402	195	245	295	346	219	275	329	388	188	234	282	334				
SK 8025	306	377	457	536	262	328	395	468	290	363	440	520	248	312	377	442	285	358	429	509	242	304	365	432				
SK 4040	242	304	368	435	224	268	337	399	223	280	339	399	200	251	304	359	209	260	316	377	183	230	278	329				
SK 6040	304	382	463	546	277	347	420	496	287	360	436	514	253	317	384	454	273	342	415	489	237	298	360	426				
SK 8040	368	462	559	660	340	427	517	610	362	454	550	650	315	395	479	565	349	437	530	625	301	378	458	541				
SK 4050	277	349	422	498	261	314	393	465	254	318	385	454	203	289	350	413	234	291	354	422	208	262	316	374				
SK 6050	343	431	522	616	324	406	491	580	327	410	497	586	292	384	444	524	307	384	466	549	271	340	411	486				
SK 8050	402	504	611	721	381	479	580	684	390	489	592	700	359	450	546	644	381	433	579	684	341	428	518	612				
SK 4060	312	393	476	561	297	360	448	530	284	356	431	508	260	327	395	467	258	322	392	466	233	293	354	419				
SK 6060	382	479	581	685	370	464	562	663	367	460	557	658	331	451	503	594	340	426	516	609	304	381	462	545				
SK 8060	436	546	662	781	422	530	642	758	417	524	634	749	402	505	612	722	413	519	628	742	380	477	578	682				
SK 4080	393	495	598	705	378	475	577	680	356	444	538	636	306	386	469	550	319	397	480	565	291	365	442	525				
SK 6080	441	554	671	792	435	546	662	781	416	522	632	746	408	512	620	732	406	509	617	728	373	468	566	669				
SK 8080	472	594	718	846	454	570	692	816	427	533	646	763	367	463	563	660	383	476	576	678	349	438	530	630				
SK 4010	529	665	805	950	522	655	794	937	499	626	758	895	490	614	744	878	487	611	740	874	448	562	679	803				
SK 6010	512	643	778	919	494	620	751	887	480	602	729																	

ArTu distribution switchgear

Dissipated power

ArTu IP 31 switchgear with ventilated side panels

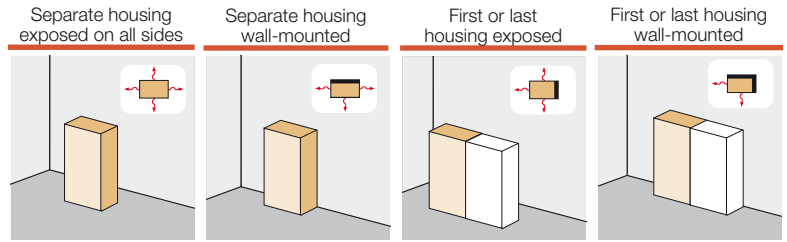

Overtemperature	Max. dissipated power (W)				Max. dissipated power (W)				Max. dissipated power (W)				Max. dissipated power (W)			
	25° C	30° C	35° C	40° C	25° C	30° C	35° C	40° C	25° C	30° C	35° C	40° C	25° C	30° C	35° C	40° C
ArTu K H 1800mm																
SK 4060	442	570	707	852	421	544	675	813	325	420	521	628	312	402	499	601
SK 6060	515	664	824	993	486	627	778	938	396	511	634	764	368	475	589	710
SK 8060	590	761	944	1138	553	713	885	1067	461	594	737	889	426	550	682	823
SK 4080	599	773	959	1155	581	749	930	1120	409	528	654	789	393	508	630	759
SK 6080	685	885	1097	1323	660	852	1057	1274	496	640	793	956	461	595	738	889
SK 8080	772	996	1236	1489	725	936	1161	1399	551	711	882	1064	498	695	863	1040
SK 4010	799	1031	1279	1540	726	936	1163	1400	511	660	818	986	462	598	741	893
SK 6010	913	1180	1463	1764	825	1065	1321	1593	620	800	991	1195	542	700	868	1046
SK 8010	1029	1328	1648	1985	906	1170	1451	1749	689	889	1103	1330	586	818	1015	1224
ArTu K H 2000mm																
SK 4060	446	574	710	855	426	550	682	822	328	425	525	632	314	406	504	605
SK 6060	529	683	847	1021	491	634	786	948	399	515	639	770	372	480	595	717
SK 8060	596	769	955	1151	565	728	904	1089	464	598	742	894	431	556	690	831
SK 4080	605	780	968	1167	584	754	935	1128	413	532	658	794	397	512	636	766
SK 6080	691	892	1107	1334	665	858	1065	1283	503	648	804	970	472	608	755	910
SK 8080	804	1037	1287	1551	738	953	1182	1425	575	742	920	1109	536	692	859	1035
SK 4010	807	1040	1291	1556	730	943	1169	1410	516	665	823	993	467	602	748	901
SK 6010	921	1189	1476	1779	831	1073	1331	1604	629	810	1005	1213	555	715	888	1071
SK 8010	1072	1383	1716	2068	923	1191	1478	1781	719	928	1150	1386	631	814	1011	1218

Dissipated power inside the ArTu switchgear according to the admissible overtemperature.

ArTu IP 31 switchgear with 2 ventilated side panels and 2 ventilated front panels H=200mm

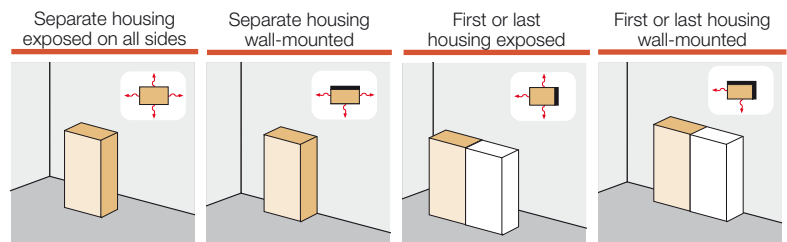

Overtemperature	Max. dissipated power (W)				Max. dissipated power (W)				Max. dissipated power (W)				Max. dissipated power (W)			
	25° C	30° C	35° C	40° C	25° C	30° C	35° C	40° C	25° C	30° C	35° C	40° C	25° C	30° C	35° C	40° C
ArTu K H 1800mm																
SK 6060	571	737	914	1102	541	698	866	1044	428	552	685	826	406	524	650	784
SK 8060	649	837	1038	1252	611	788	978	1179	502	648	804	969	460	593	736	887
SK 6080	737	951	1180	1422	712	919	1140	1374	552	713	884	1066	518	668	829	999
SK 8080	836	1079	1339	1613	787	1016	1261	1519	625	806	1000	1205	595	768	953	1149
ArTu K H 2000mm																
SK 6060	586	756	938	1131	546	705	874	1131	434	560	695	838	407	525	651	785
SK 8060	654	844	1047	1261	623	804	997	1202	507	654	811	978	468	604	749	903
SK 6080	741	956	1186	1429	715	923	1145	1380	560	723	897	1081	527	680	843	1016
SK 8080	861	1112	1379	1662	792	1022	1268	1528	640	826	1024	1234	596	769	955	1151

Dissipated power inside the ArTu switchgear according to the admissible overtemperature.

ArTu distribution switchgear

Dissipated power

ArTu IP 41 switchgear with ventilated side panels

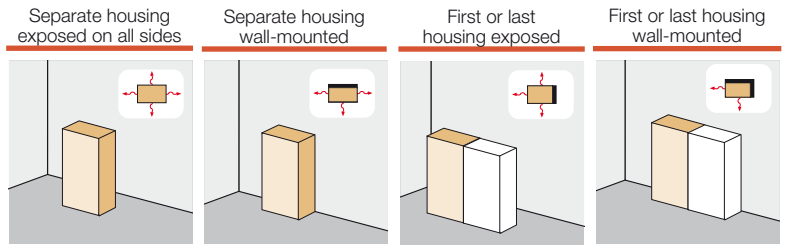

Overtemperature			Max. dissipated power (W)				Max. dissipated power (W)				Max. dissipated power (W)				Max. dissipated power (W)			
			25° C	30° C	35° C	40° C	25° C	30° C	35° C	40° C	25° C	30° C	35° C	40° C	25° C	30° C	35° C	40° C
ArTu K H 1800mm																		
	SK 4060		418	539	669	806	398	514	637	768	317	409	507	611	304	392	486	586
	SK 6060		489	631	783	944	462	596	739	891	376	485	602	725	350	451	560	674
	SK 8060		560	723	897	1081	525	678	841	1013	438	565	700	844	405	523	648	781
	SK 6080		651	840	1042	1256	627	809	1004	1210	471	608	754	909	438	565	701	845
	SK 4080		562	725	899	1084	544	703	872	1051	395	509	632	761	382	493	612	738
	SK 8080		733	946	1174	1415	689	889	1103	1329	524	676	838	1010	473	661	819	988
	SK 4010		749	967	1199	1445	725	937	1163	1401	494	636	790	951	449	580	720	868
	SK 6010		868	1120	1389	1675	836	1079	1339	1613	589	760	943	1136	515	665	825	994
	SK 8010		977	1261	1565	1887	919	1185	1471	1772	655	845	1048	1263	556	778	964	1162
ArTu K H 2000mm																		
	SK 4060		422	543	671	809	403	519	644	777	320	413	511	615	309	398	492	591
	SK 6060		503	649	805	970	466	602	747	900	379	489	607	732	353	456	565	681
	SK 8060		566	731	907	1093	536	692	859	1035	440	568	705	850	410	528	656	790
	SK 4080		567	732	908	1094	547	706	876	1056	398	514	635	765	389	498	617	743
	SK 6080		657	847	1051	1267	632	815	1011	1219	477	616	764	921	448	578	717	864
	SK 8080		764	985	1222	1474	701	905	1123	1353	546	705	874	1054	510	658	816	983
	SK 4010		756	976	1211	1459	729	941	1168	1408	498	643	794	956	458	586	726	874
	SK 6010		876	1129	1401	1689	843	1087	1348	1625	596	770	955	1151	527	680	844	1016
	SK 8010		1019	1313	1629	1965	935	1207	1497	1804	683	881	1093	1318	600	774	960	1156

Dissipated power inside the ArTu switchgear according to the admissible overtemperature.

ArTu distribution switchgear

Dissipated power

ArTu IP 43 switchgear

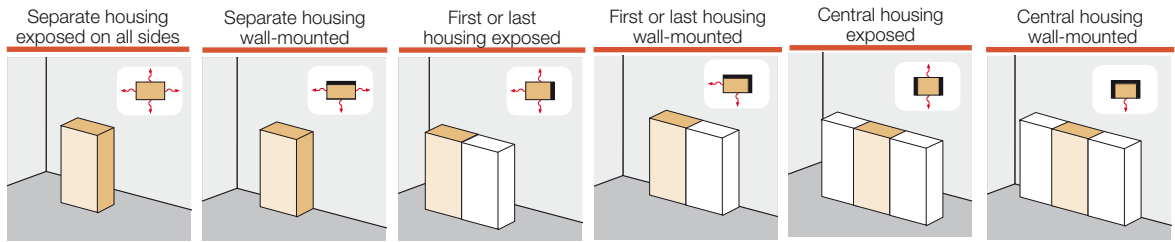

	Max. dissipated power (W)				Max. dissipated power (W)				Max. dissipated power (W)				Max. dissipated power (W)				Max. dissipated power (W)				Max. dissipated power (W)											
	25° C	30° C	35° C	40° C	25° C	30° C	35° C	40° C	25° C	30° C	35° C	40° C	25° C	30° C	35° C	40° C	25° C	30° C	35° C	40° C	25° C	30° C	35° C	40° C	25° C	30° C	35° C	40° C				
Overtemperature																																
ArTu L																																
SL0600					90	113	137	162					86	108	131	155					82	103	125	147								
SL0800					97	122	147	174					92	115	140	165					98	122	148	175								
SL1000					113	141	171	202					107	134	162	191					104	131	158	187								
SL1200					126	159	192	227					120	151	181	214					117	146	177	209								
SL1400	158	197	241	284	141	177	215	253	153	192	232	274	132	166	201	237	149	187	227	268	127	160	194	229								
SL1600	176	220	267	315	155	194	235	278	168	211	255	302	145	182	220	260	164	205	249	294	140	175	212	251								
SL1800	192	240	291	344	167	210	255	301	182	228	277	327	157	197	238	281	177	222	269	318	151	189	229	271								
SL2000	206	259	314	371	179	225	273	322	195	245	297	351	168	210	253	301	190	238	289	341	162	203	246	290								
SL1408	224	281	340	402	187	234	283	335	215	270	327	386	179	224	272	320	208	261	316	373	173	217	262	310								
SL1608	248	311	377	445	210	263	319	377	240	301	365	431	200	251	301	359	230	289	350	413	192	241	292	345								
SL1808	260	326	395	466	223	280	339	401	253	317	384	453	214	268	325	384	244	306	371	438	208	261	316	374								
SL2008	275	345	419	494	246	309	374	441	271	340	412	486	239	299	363	428	267	334	405	478	231	289	350	414								

Dissipated power inside the ArTu switchgear according to the admissible overtemperature.

ArTu distribution switchgear

Dissipated power

ArTu IP 65 switchgear

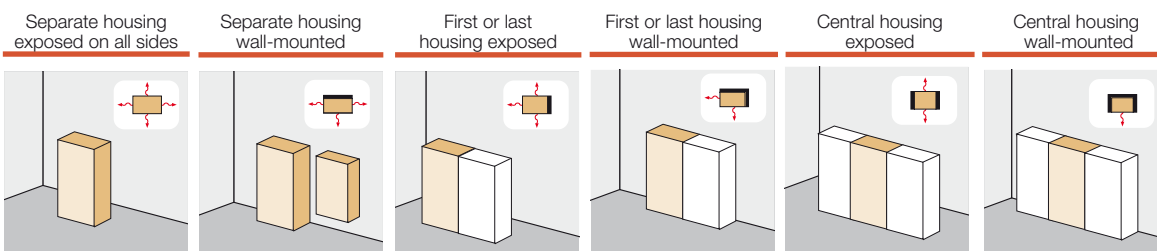

	Max. dissipated power (W)				Max. dissipated power (W)				Max. dissipated power (W)				Max. dissipated power (W)				Max. dissipated power (W)				Max. dissipated power (W)							
	25° C	30° C	35° C	40° C	25° C	30° C	35° C	40° C	25° C	30° C	35° C	40° C	25° C	30° C	35° C	40° C	25° C	30° C	35° C	40° C	25° C	30° C	35° C	40° C	25° C	30° C	35° C	40° C
Overtemperature																												
ArTu M																												
SM 6061					70	88	107	126																				
SM 8061					71	90	108	128																				
SM 8062					83	104	126	149																				
SM 1062					95	119	145	171																				
SM 1262					107	134	162	192																				
SM 1462	159	200	242	278	141	177	215	254	153	192	233	275	132	166	201	237	149	187	227	268	127	160	194	229	138	174	210	248
SM 1662	175	219	265	313	154	193	234	276	167	209	253	299	144	180	218	258	162	204	247	291	138	174	210	248	146	184	222	263
SM 1682	221	277	336	396	194	244	295	348	215	269	326	385	184	230	279	329	212	265	321	380	179	224	272	321	149	186	226	267
SM 1862	189	237	287	339	165	207	251	297	180	225	273	322	154	194	235	277	175	219	265	313	149	186	226	267	179	224	272	321
SM 1882	240	301	365	431	210	263	319	376	232	291	353	417	198	249	301	355	229	287	348	410	193	242	294	347	158	199	241	284
SM 2062	203	254	308	364	176	221	268	316	192	240	291	344	164	206	250	295	186	233	282	334	158	199	241	284	186	233	282	334
SM 2082	259	324	393	464	224	282	341	403	249	312	379	447	212	266	322	380	245	307	372	440	207	259	314	371	207	259	314	371
ArTu K																												
H 1600mm																												
SK 6025	182	228	276	326	161	202	245	289	175	219	266	314	151	189	229	271	170	214	259	306	145	182	221	261	145	182	221	261
SK 8025	232	291	353	416	203	255	309	365	225	282	342	404	192	241	292	345	222	278	337	398	189	237	287	338	189	237	287	338
ArTu K																												
H 1800mm																												
SK 6025	199	250	303	357	175	220	266	315	190	239	289	342	164	206	249	294	185	233	282	333	158	198	240	283	158	198	240	283
SK 8025	251	315	382	451	221	277	335	396	244	307	371	439	209	262	317	375	241	302	366	432	204	256	310	365	204	256	310	365
SK 4040	193	242	293	346	179	224	271	320	178	223	270	319	160	201	243	287	165	207	251	296	146	184	222	263	146	184	222	263
SK 6040	254	318	385	455	230	289	350	413	238	299	362	428	210	264	320	378	227	285	345	407	198	249	301	356	198	249	301	356
SK 8040	316	397	481	568	284	356	431	509	302	378	458	541	263	330	400	472	291	365	442	521	252	316	383	452	252	316	383	452
SK 4050	223	284	344	406	213	267	323	381	206	258	313	370	188	236	286	338	188	236	286	338	170	213	258	305	170	213	258	305
SK 6050	292	366	443	524	268	336	407	481	271	341	413	488	242	304	368	435	279	319	386	456	226	284	343	406	226	284	343	406
SK 8050	346	435	526	622	326	409	496	586	332	417	505	596	301	378	458	540	324	407	493	581	286	358	434	513	286	358	434	513
SK 4060	260	326	395	466	247	310	375	443	235	294	357	421	217	272	329	389	212	266	322	381	194	243	295	348	194	243	295	348
SK 6060	331	415	502	593	306	384	465	549	305	383	464	548	275	344	417	493	282	353	428	505	254	319	386	456	254	319	386	456
SK 8060	377	473	572	676	369	463	561	663	363	456	552	652	339	426	516	609	358	449	544	642	320	401	486	574	320	401	486	574
SK 4080	328	411	498	588	317	398	482	569	290	364	440	520	274	344	417	492	259	325	394	465	243	304	369	435	243	304	369	435
SK 6080	381	478	579	684	379	476	577	681	362	455	551	650	345	433	524	619	341	428	519	612	314	393	477	563	314	393	477	563
SK 8080	435	546	661	781	425	533	646	763	412	517	626	739	400	502	608	718	404	507	614	725	386	484	586	692	386	484	586	692
SK 4010	386	484	586	692	373	468	567	669	341	428	518	612	322	405	491	579	305	382	464	547	286	358	434	512	286	358	434	512
SK 6010	448	562	681	805	446	560	679	801	426	535	648	765	406	509	616	728	401	504	611	720	369	462	561	662	369	462	561	662
SK 8010	512	642	778	919	500	627	760	898	485	608	736	869	471	591	715	845	475	596	722	853	454	569	689	814	454	569	689	814
ArTu K																												
H 2000mm																												
SK 6025	216	270	328	387	189	237	287	338	205	257	312	368	176	221	268	316	199	250	303	358	170	213	258	305	170	213	258	305
SK 8025	273	343	415	490	239	299	362	428	265	332	402	475	225	283	343	404	261	327	396	467	220	276	334	395	220	276	334	395
SK 4040	209	262	317	375	192	241	292	345	191	240	291	343	172	216	262	309	178	223	270	319	157	197	239	282	157	197	239	282
SK 6040	271	340	412	486	246	309	374	442	255	320	388	458	225	282	342	404	243	305	369	436	211	265	321	379	211	265	321	379
SK 8040	328	411	498	588	303	380	460	543	322	404	490	578	280	352	426	503	310	389	471	557	268	337	408	481	268	337	408	481
SK 4050	244	306	371	438	228	287	347	410	221	278	337	397	202	254	307	363	202	254	308	363	182	228	277	327	182	228	277	327
SK 6050	305	383	464	548	287	361	437	516	290	364	442	521	260	342	395	466	272	342	414	459	241	302	366	432	241	302	366	432
SK 8050	358	448	543	641	339	404	515	609	346	406	527	622	319	400	485	573	339	425	515	608	303	380	461	544	303	380	461	544
SK 4060	279	351	425	501	265	333	403	476	252	316	383	452	232	292	353	417	227	285	346	408	207	260	315	372	207	260	315	372
SK 6060	340	426	517	610	329	413	500	590	326	409	496	585	295	402	448	528	302	379	459	542	271	339	411	485	271	339	411	485
SK 8060	388	486	589	695	376	472	571	675	371	466	565	667	358	449	544	643	368	462	559	660	338	424	514	607	338	424	514	607
SK 4080	354	444	537	634	341	428	519	612	314	394	478	564	295	370	448	529	278	349	423	499	258	324	393	464	258	324	393	464
SK 6080	393	493	597	705	387	486	589	692	370	464	562	664	363	455	552	651	361	453	549	648	332	416	504	595	332	416	504	595
SK 8080	456	572	693	818	440	552	668	789	427	536	649	766	410	515	624	736	415	521	631	745	401	503	610	720	401	503	610	720
SK 4010	416	522	632	746	401	504	611	720	369	464	562	664	347	435	527	622	327	411	498	587	304	381	462	546	304	381	462	546
SK 6010	462	580	702	829	455	572	693	818	435	546	661	781	427	535	649	766	425	533	646	762	391	489	593	700	391	489	593	700
SK 8010	536	673	815	962	518	649	786	928	502	631	764	901	482	606	734	866	488	613	742	876	472	592	718	847	472	592	718	847

Dissipated power inside the ArTu switchgear according to the admissible overtemperature.

ArTu distribution switchgear

Handling

Handling with transpallet

Palletisable base strip for ArTu M and ArTu K

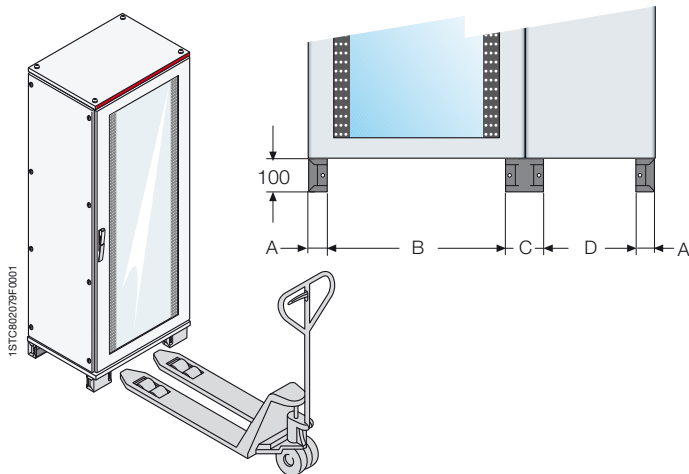

For greater safety during transport using a fork-lift truck, it is advisable to anchor the switchgear to the truck:

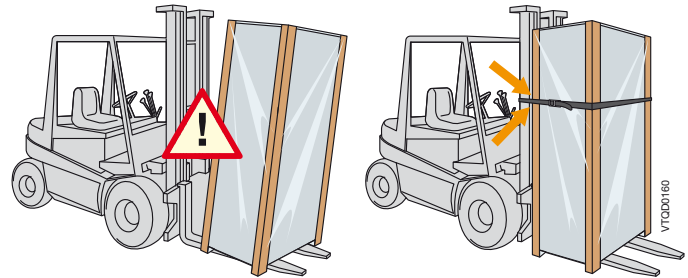

Handling ArTu K structures by means of rollers: only with **ZR...** reinforced plinth

Structure	A (mm)	B (mm)	C (mm)	D (mm)
ArTu L				
Width 600mm	47	596	97	296
ArTu M				
Width 600mm	125,5	469	251	
Width 800mm	125,5	669	251	
ArTu K				
Width 400mm	125,5	259	251	
Width 600mm	125,5	469	251	
Width 800mm	125,5	669	251	
Width 200mm (cable container)	125,5		251	69
Width 300mm (cable container)	125,5		251	169

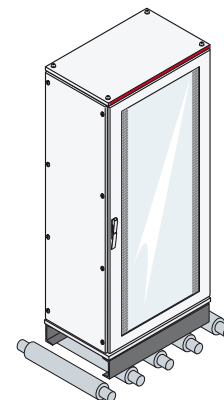

For switchgear with reduced depth, the following type of handling is recommended:

In the case of structures W=800mm (with internal or external cable container) containing busbar systems, check the centre of gravity before handling.

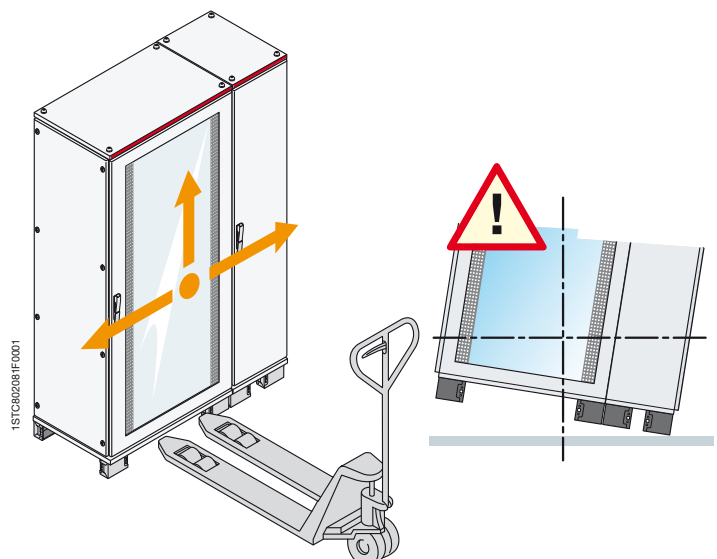
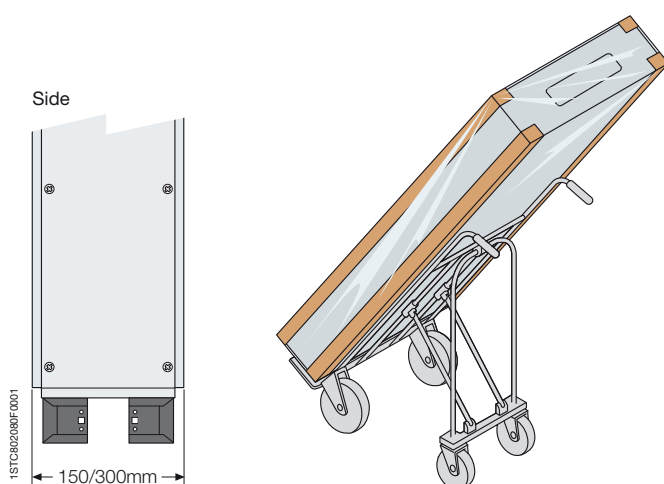

ArTu distribution switchgear

Handling

Handling with overhead travelling crane

To handle using a crane or overhead travelling crane, check the following conditions before lifting the switchgear:

- excellent state of the ropes or chains;
- the angle between the lifting ropes and the switchgear roof must be $\geq 45^\circ$;
- the maximum number of columns transported is 3;
- **ArTu L** maximum weight lifted as per DIN 580 (M8);
- **ArTu M - K** maximum weight lifted as per DIN 580 (M12) Standard.

To respect the conditions described above, a lifting beam with appropriate characteristics can be used when there are several columns side by side.

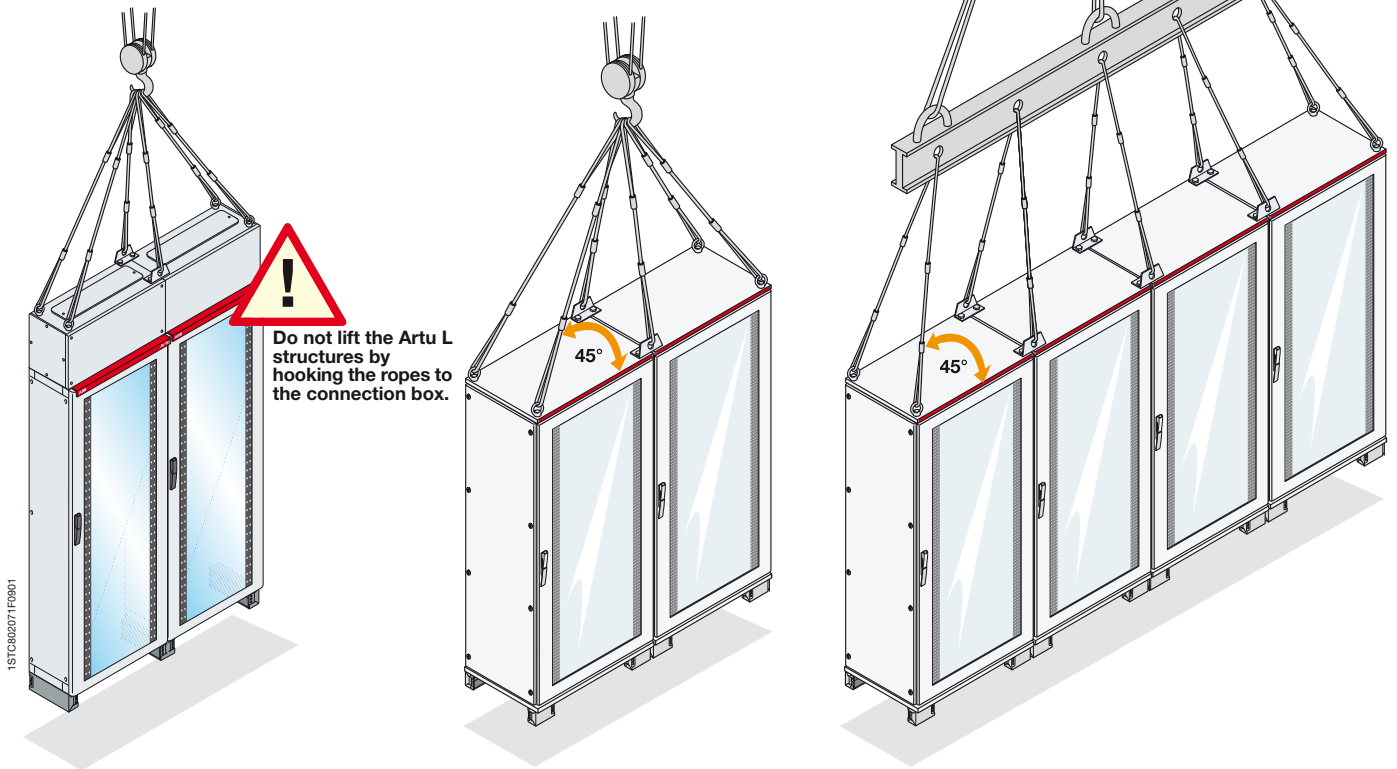

6

DIN 580 Standard regarding mechanical connection elements (only for lifting eyebolts)

Lifting eyebolts		Lifting reinforcements								
	A	B (mm)	C (mm)	D (mm)	E (mm)	F (mm)	G (mm)	Load 1 kg	Load 2 kg	Tightening Nm
Lifting eyebolts										
ArTu L	M8	30	8	18	6	15	20	140	95	8*
ArTu M - K	M12	54	12	28	10	22	30	340	240	8*
Lifting reinforcements										
ArTu L	M8	ø20	30	60	28	ø10	40	210	140	22
ArTu M - K	M12	ø40	37	80	25	ø14	60	510	350	40

* Close by hand without mechanical elements in order to avoid overvoltage in the stem that will reduce the capacity of the lifting eyebolts.

ArTu distribution switchgear

Electrical continuity

Electrical continuity of the structure and of the fixed and mobile parts

Pic. 1
Electrical continuity in ArTu switchgear is guaranteed automatically just with assembly of the structure without the use of dedicated accessories.

Pic. 2
In the case of mobile parts (e.g. front panels), electrical continuity is guaranteed in the closed position by the special shape of the hinge (ABB patent) which is always supplied with the panels.

Pic. 3
The special shape of the hinge allows connection even using a traditional copper braid.

Pic.4
The blind door, side panels and rear panels are fitted with copper M6 captive screws. Panel earthing is obtained thanks to the fixing screws.

Pic. 1

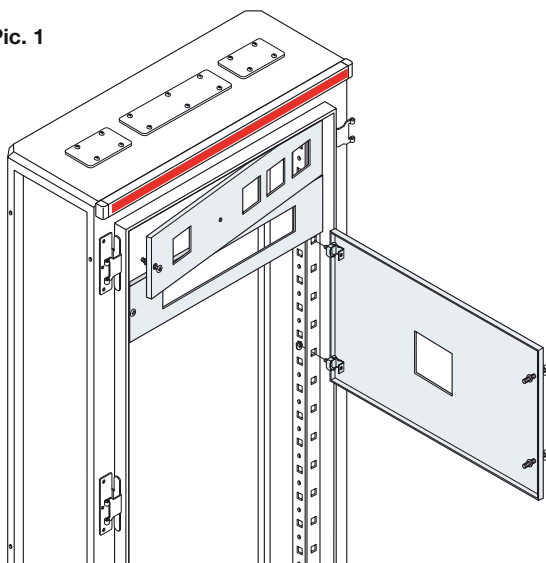

Pic. 2

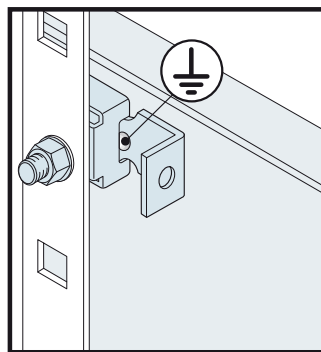

Pic. 3

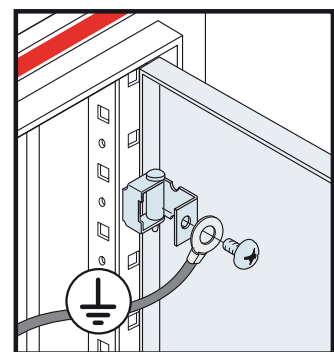

Pic. 4

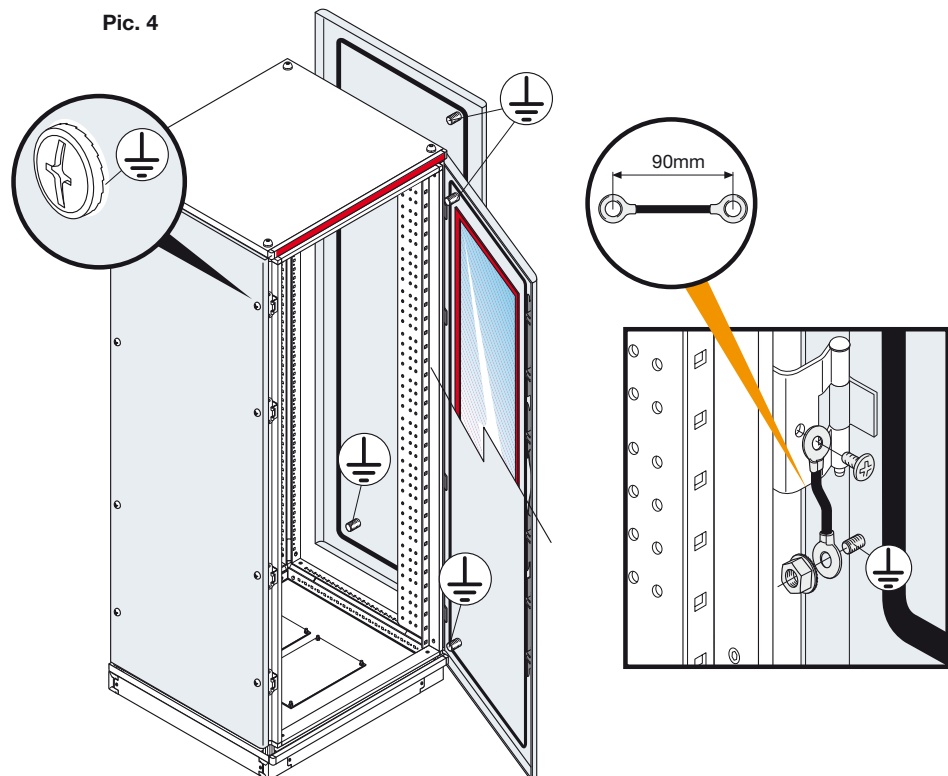

15TC02038F0901

ArTu distribution switchgear

Equipotential conductors

Calculation of the PE protection conductor

The IEC 60439-1 Standard indicates the methods of calculation for the cross-section of the PE protection conductor which must be suitably sized to withstand the thermal and dynamic components of the fault currents.

In identifying the fixing position of the busbar, check the following conditions:

- the busbar must be connected directly to the switchgear exposed conductive parts (structure);
- the busbar must be connected in an easily accessible position.

For sizing, use the values in the table, taken from the IEC 60439-1 Standard (P.7.4.3.1.7).

Section of the phase conductors		Minimum section of the corresponding protection conductor
S	S_p	S_p
(mm ²)		(mm ²)
$S \leq 16$	S	S
$16 < S \leq 35$	S	16
$35 < S \leq 400$	S	S/2
$400 < S \leq 800$	S	200
$S > 800$	S	S/4

Wall-mounted ArTu L
Protection conductor section (25x4) 100mm² (art. BR0400)

Floor-mounted ArTu L
Protection conductor section (25x4) 100mm² (art. BR0400)

Wall-mounted ArTu M
Certified ACAE/LOVAG No. IT 99.024 with protection conductor section (25x4) 100 mm² (art. BR0400)

Floor-mounted ArTu M
Certified ACAE/LOVAG No. IT 99.022 with protection conductor section (25x4) 100 mm² (art. BR6305)

ArTu K
Certified ACAE/LOVAG No. IT 99.025 with protection conductor section (50x5) 250 mm² (art. BR6305)

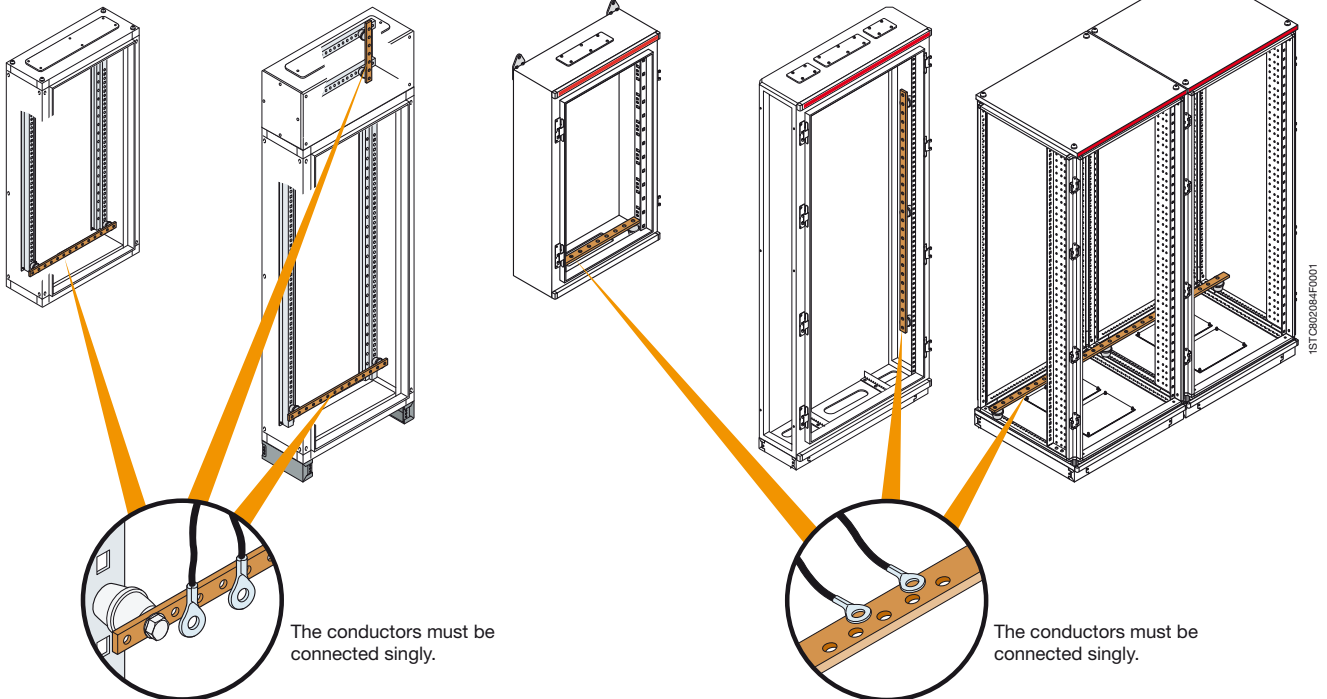

Equipotentiality

The accessible conductive parts of a device, which cannot be connected to the protection circuit by their own means of connection, must be connected to the protection circuit of the apparatus for equipotentiality of the protection by means of an equipotential conductor, whose section must be selected according to the table given below.

Rated service current	Minimum section of the equipotential protective conductor
I_n (A)	(mm ²)
$I_n \leq 20$	S
$20 < I_n \leq 25$	2,5
$25 < I_n \leq 32$	4
$32 < I_n \leq 63$	6
$63 < I_n$	10

S = section of the phase conductor (mm²)

PEN conductor

The section of the PEN conductors of the apparatus must be determined using the same procedure followed for the neutral conductor (N).

The minimum section of a copper conductor must be 10mm².

The PEN conductor does not need to be insulated.

The parts of the structure must not be used as a PEN conductor. However, the assembly tracks, made of copper or aluminium, can be used as PEN conductors.

For conductors not made of copper, the sections above are replaced with equivalent conductivity sections, which may require larger sized terminals.

ArTu distribution switchgear

Degrees of protection

1st NUMBER: protection against solid bodies

2nd NUMBER: protection against liquids

IP	
0	No protection
1	Protected against solid bodies larger than 50mm (accidental contact with hands)
2	Protected against solid bodies larger than 12 mm (fingers)
3	Protected against solid bodies larger than 2.5mm (tools, wires)
4	Protected against solid bodies larger than 1 mm
5	Protected against dust (no harmful deposit)
6	Totally protected against dust

IP	
0	No protection
1	Protected against vertical fall of drops of water (condensation)
2	Protected against drops of water up to 15° from vertical
3	Protected against drops of water up to 60° from vertical
4	Protected against splashes of water from all directions
5	Protected against jets of water from all directions by means of a hose
6	Protection against jets of water similar to sea waves
7	Protected against the effects of temporary immersion
8	Protected against the effects of continual immersion

1st number defined by the CEI EN 60529 – IEC 529 Standards

2nd number defined by the CEI EN 60529 – IEC 529 Standards

15TCB2095FW001

ArTu distribution switchgear

Degrees of protection

PROTECTION AGAINST PENETRATION OF SOLID BODIES

1 st characteristic number	Brief description	Complete description
0	Unprotected is provided	No particular protection
1	Protected against solid bodies larger than 50mm	No large surface of the human body must be able to penetrate, for example a hand (voluntary protection is not provided) or solid bodies larger than 50mm in diameter.
2	Protected against solid bodies larger than 12mm	Fingers or similar objects of length not exceeding 80mm or solid bodies of diameter higher than 12 mm must not penetrate
3	Protected against solid bodies larger than 2.5mm	Tools, wires, etc. with diameter or thickness greater than 2.5mm or solid bodies with diameter greater than 2.5mm must not be able to penetrate
4	Protected against solid bodies larger than 1.0mm	Wires or plates thicker than 1.0mm or solid bodies with diameter greater than 1.0mm must not be able to penetrate
5	Protected against dust	Penetration of dust is not totally excluded, but the amount penetrating is not enough to harm correct operation of the material
6	Totally protected against dust	No penetration of dust is allowed

PROTECTION AGAINST PENETRATION OF WATER

2 nd characteristic number	Brief description	Complete description
0	Unprotected	No particular protection is provided
1	Protected against vertical fall of drops of water	The drops of water which fall vertically must not cause harmful effects
2	Protected against drops of water up to 15° from vertical	The drops of water which fall vertically must not cause harmful effects when the housing is leant at any angle up to 15° in relation to its normal position
3	Protected against rain	The water which falls like rain from a direction with an angle of up to 60° to vertical must not cause harmful effects
4	Protected against splashes of water	Water splashed over the housing from all directions must not cause harmful effects
5	Protected against jets	Water sprayed with a nozzle onto the housing from all direction must not cause harmful effects
6	Protected against waves	In the case of waves or strong jets of water, the water must not enter the housing in a harmful amount
7	Protected against the effects of temporary immersion	Water in a harmful amount must not be able to penetrate inside the housing immersed in certain pressure and duration conditions
8	Protected against the effects of continual immersion	The material is suited to remaining immersed in water in the conditions specified by the manufacturer

6

Degrees of protection which can be obtained with ArTu switchgear

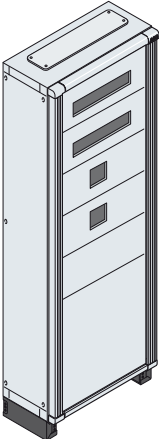
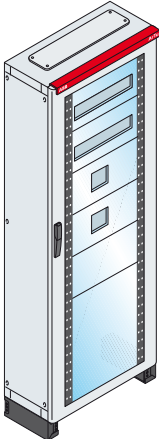
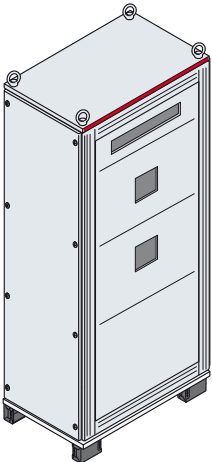
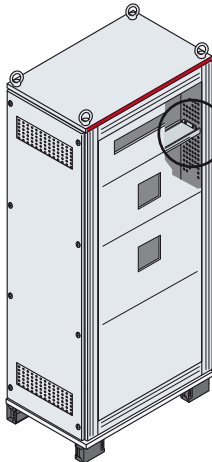
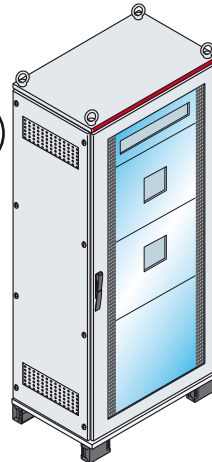
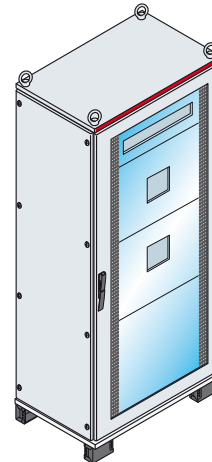
ArTu L IP31 Without door	IP43 With door	ArTu M - K IP31 Without door	IP41 (only ArTu K) Without door with IP41 kit and side ventilated panels	IP41 (only ArTu K) With door and side ventilated panels	IP65 With door and blind panels
					

ArTu distribution switchgear

IK mechanical resistance to impact

IK mechanical resistance

IK 0



Unprotected

IK 06



Impact energy in Joules **1,00**

IK 01

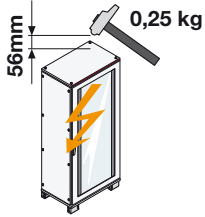

Impact energy in Joules **0,140**

IK 07

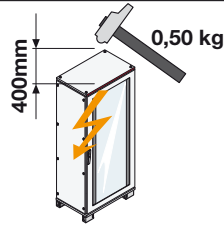

Impact energy in Joules **2,00**

IK 02

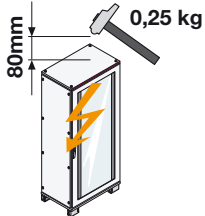

Impact energy in Joules **0,200**

IK 08

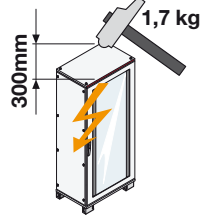

ArTu L
Impact energy in Joules **5,00**

IK 03

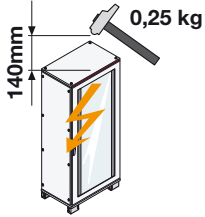

Impact energy in Joules **0,350**

IK 09

With glazed door

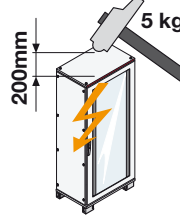

ArTu M - K
Impact energy in Joules **10,00**

IK 04

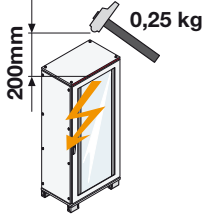

Impact energy in Joules **0,500**

IK 10

With blind door

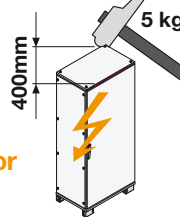

ArTu M - K
Impact energy in Joules **20,00**

IK 05

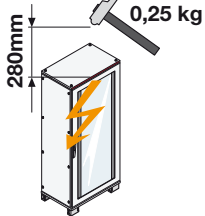

Impact energy in Joules **0,700**

Figure defined by the CEI EN 50102 Standard

1STC02039F0901

Busbars with shaped section and flat bars

Mechanical and electrical characteristics

Compliance with CEI EN 60439-2/IEC 61439-1-2 Standard

The ArTu switchgear has undergone the type tests foreseen by the CEI EN 60439-2/IEC 61439-1-2 Standards in the ABB laboratories. The results of these tests guarantee the performances of the ArTu switchgear and, by using the ABB SACE metalwork structures and accessories, such as the modular and moulded-case circuit-breakers, allow the end switchgear constructor not to carry out any further type tests by following the selection criteria and the assembly instructions for the various components, and only carrying out the individual tests foreseen under the CEI EN 60439/IEC 61439-1-2 Standard. These results, which are indicated below, can be referred to for making out the declaration of conformity of the switchgear.

Technical characteristics

Components	Material									
Components	Material									
Busbars	electrolytic copper 99.9% CU-ETP									
Busbar holders	self-extinguishing thermoplastic VO									
Tightening screws	Mad. class 8.8									
Busbars	Code	Length (mm)	IP 31	IP 41	IP 65	Icw (kA)	Ipk (kA)	Dimensions (mm)	Section (mm ²)	Weight (Kg)
In 400	BA400	1730	630	520	400	35	74	20x20	200	4
In 800	BA800	1730	970	830	800	35	74	20x20	283	4.4
In 1250	BA1250	1730	1400	1330	1250	75	165	20x60	603	9.3
In 1600	BA1600	1730	1820	1710	1600	75	165	20x60	703	10
In 2000	BA2000	1730	2350	2200	2000	100	220	25x60	1000	14.8
Tightening torque	Screws M6 - 10N.m									
	Screws M8 - 20N.m									
	Screws M10 - 30N.m									





Ambient characteristics

Type of installation	indoors	
Installation conditions	Wall / Floor-mounted	
Service climate (t°/r.h.%)	constant	23 °C/83% - 40 °C/93%
	variable	23 °C/98% - 40 °C/98%
Ambient temperature limits	for operation	-5 °C +40 °C
	for storage	-25 °C +55 °C

Busbars with shaped section

Characteristics of the components

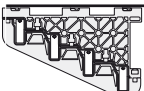
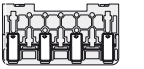
Busbar holders for busbars with shaped section up to 100 kA

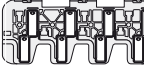
Type	Icc (kA)	Code	Busbar					Application						
			400A BA0400	800A BA0800	1250A BA1250	1600A BA1600	3200A BA2000	ArTu L struct.	cable cont. drawer	ArTu M struct.	cable cont.	ArTu K struct.	cable cont.	
	35	PB0802	L1-L2-L3	3x BA0400	3x BA0800									
			N 100%	1x BA0400	1x BA0800				•		•		•	
			N. reduced		1x BA0400									
	35	PB0803	L1-L2-L3	3x BA0400	3x BA0800									
			N 100%	1x BA0400	1x BA0800				•	•	•	•		
			N. reduced		1x BA0400									
	75	PB1600⁽¹⁾	L1-L2-L3			3x BA1250	3x BA1600							
			N 100%			1x BA1250	1x BA1600					D _≥ 700	D _≥ 700	
			N. reduced				1x BA1250							
	65	PB1603⁽¹⁾	L1-L2-L3			3x BA1250	3x BA1600							
			N 100%			1x BA1250	1x BA1600					D _≥ 500	D _≥ 500	
			N. reduced				1x BA1250							
	75	PB1601⁽¹⁾	L1-L2-L3			3x BA1250	3x BA1600							
			N 100%			1x BA1250	1x BA1600					D _≥ 500	D _≥ 500	
			N. reduced				1x BA1250							
	100	PB3201	L1-L2-L3					6x BA2000						
			N 100%						2x BA2000				D _≥ 700	D _≥ 700
			N. reduced						1x BA2000					

⁽¹⁾ It is possible to mount the 400/800A busbars with the special adapter **AD1066** see example on page 4/29.

6

Example of use of adapter for busbars

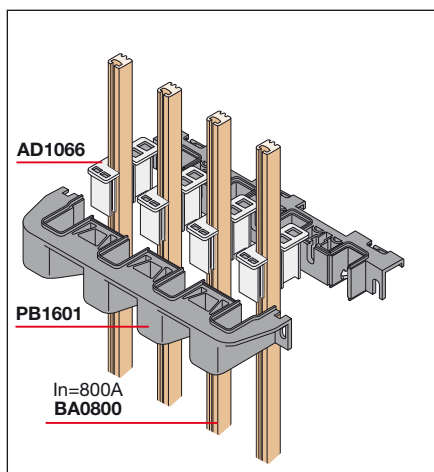

Example of use of 2 busbars per phase (3200A)

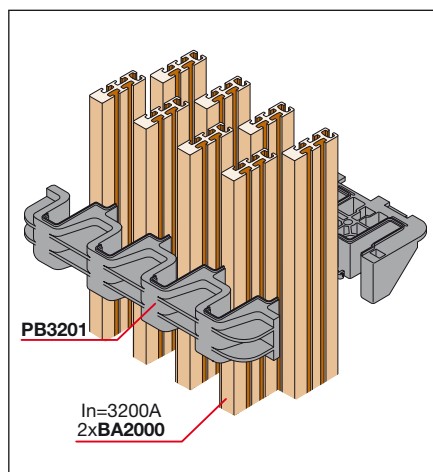

Example of use of the busbar with reduced neutral

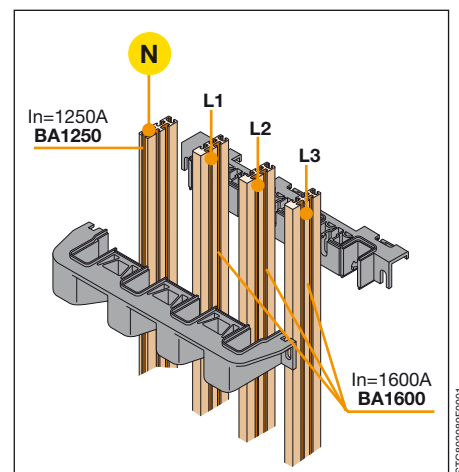

Busbars with shaped section

Characteristics of the components

Components

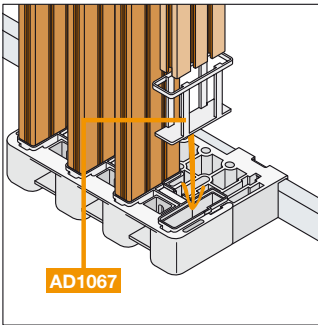

The busbar holders can be used both in intermediate and end positions, thanks to the special support.

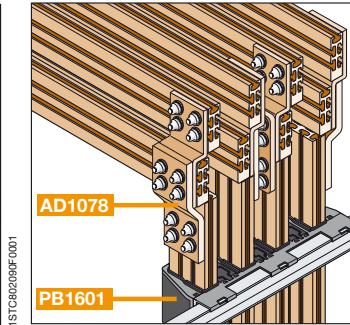

Branch between 3200A busbars with shaped section and 1250/1600A busbars with shaped section.

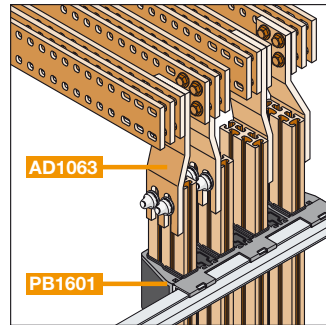

Branch between 3200A flat busbars and 1250/1600A busbars with shaped section.

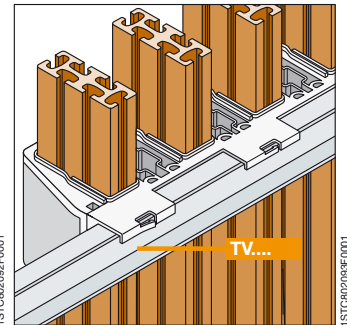

Snap-on assembly between busbar holders and assembly crosspieces.

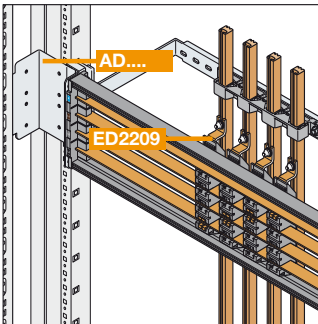

Direct connection with Unifix H system.

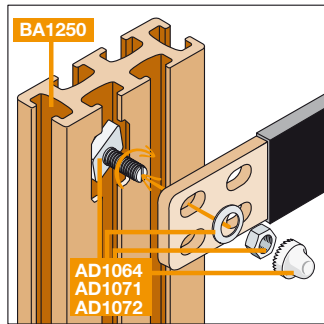

A self-locking hammer screw allows fixing between conductors in any position along the busbar, ensuring a large contact surface.

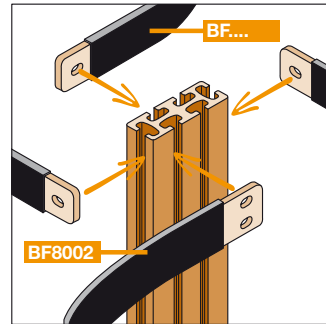

The connections can be made on each side of the busbar.

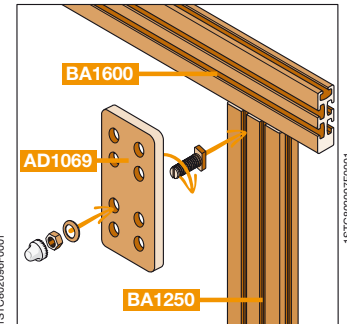

Joint for 1250-1600A busbars. Example of "T" or "L" coupling.

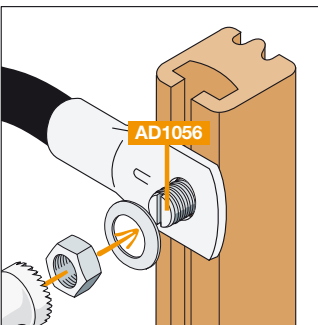

Direct branch by means of cable terminal for cable section up to 50mm².

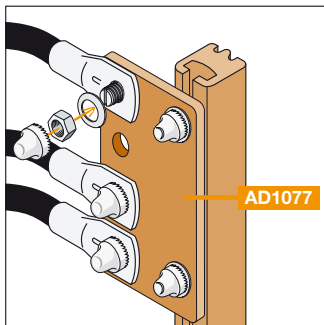

Branch by means of accessory.



Note
branches headed with cable terminal with the following dimensions:

Cable section mm ²	A	B	C	D
	16	9	13	6
25	10.5	13	7	35
35	14	17	9	41
50	15	20	10	42

Flat busbars

Characteristics of the components

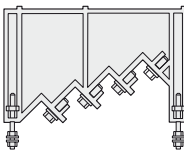
Busbar holders for flat busbars up to 32 kA

Type	I _{cc} (kA)	Code	Busbars			Application		
			250A BR0250	400A BR0400	630A BR0630	Structure	Cable cont./ box	
Scaled 	23	BP0634	L1-L2-L3	3x BR0250	3x BR0400	3xBR0630		•
			Neutral 100%	1x BR0250	1x BR0400	1xBR0630		
Linear 	32	BP0630	L1-L2-L3	3x BR0250	3x BR0400	3xBR0630	•	•
			Neutral 100%	1x BR0250	1x BR0400	1xBR0630		

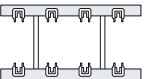
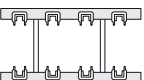
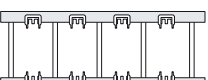
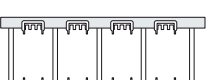
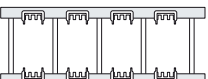
Type	I _{cc} (kA)	Code	Busbar					Application
			400A BR4005	630A BR6305	800A BR8005	1250A BR1250	1600A BR1600	ArTu K structure/cable container
Linear 	50	BP1250	L1-L2-L3	3x BR4005	3x BR6305	3xBR8005	3xBR1250	P _≥ 500
			Neutral 100%	1x BR4005	1x BR6305	1xBR8005	1xBR1250	
Linear 	75	BP1600	L1-L2-L3				3xBR1600	P _≥ 500
			Neutral 100%				1xBR1600	
Linear 	105	BP2500	L1-L2-L3				6xBR1600	P _≥ 700
			Neutral 100%				2xBR1600	
Linear 	105	BP3200	L1-L2-L3				9xBR1600	P _≥ 700
			Neutral 100%				3xBR1600	
Linear 	105	BP3200	L1-L2-L3				9xBR2000	P _≥ 900
			Neutral 100%				3xBR2000	

Flat busbars

Characteristics of the components

Components

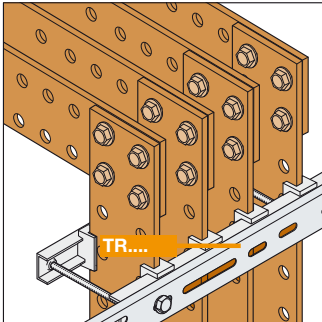

The 25mm pitch drilling allows branching between flat busbars at any point.

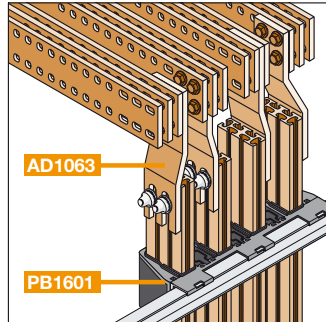

Branch between pre-drilled 3200A flat busbars and 1250/1600A busbars with shaped section (only with PB1601).

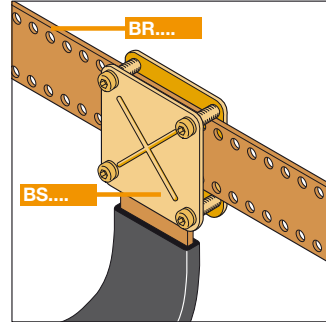

Branch between flat busbar and flexible busbar by means of tightening plate.

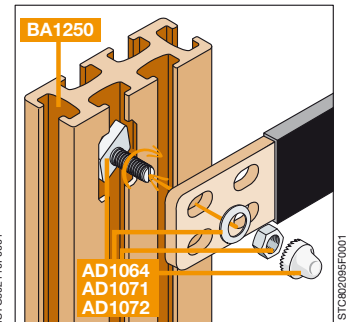

A self-locking hammer screw (M8) allows fixing between conductors in any position along the busbar with shaped section, ensuring a large contact surface.

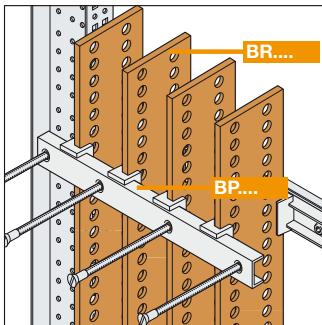

Busbar holder for flat busbars (one busbar per phase).

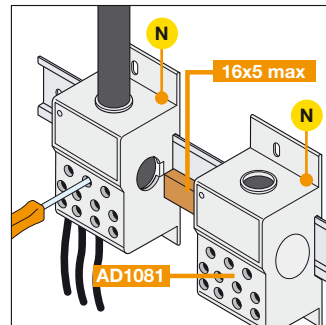

Single-phase divider with possibility of connection, which can be mounted on DIN rail.

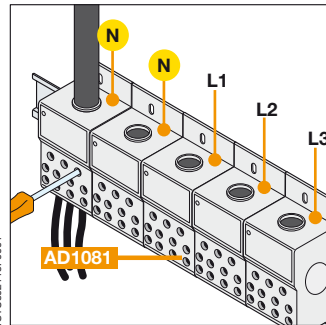

Single-phase dividers up to 400A, which can be mounted on DIN rail.

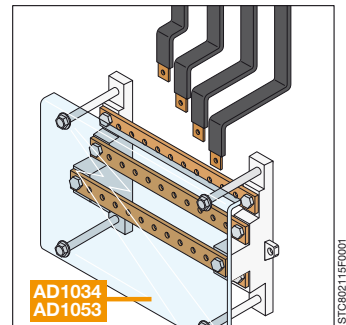

Four-pole 250A divider.

Unifix cabling system

Examples of connections - Unifix H

Unifix H frame with 400A 24 and 36 module busbars

Busbar power supply from the top by means of 4P feeder module placed laterally

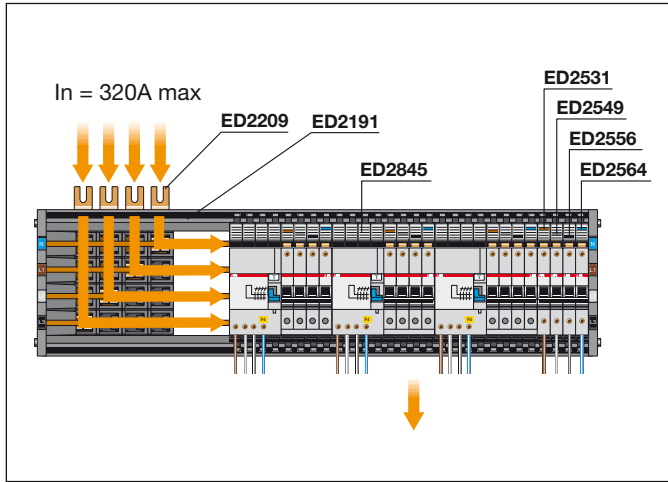

Unifix H frame with 400A 24 and 36 module busbars

Busbar power supply from the top by means of main row circuit-breaker

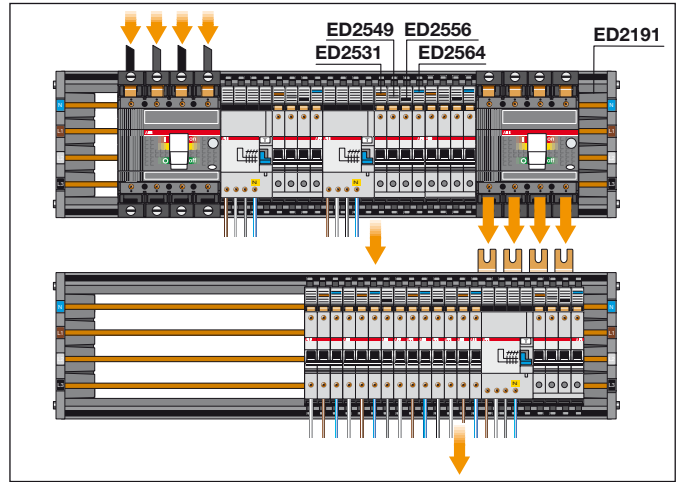

Busbar power supply from the bottom by means of 4P feeder module placed laterally

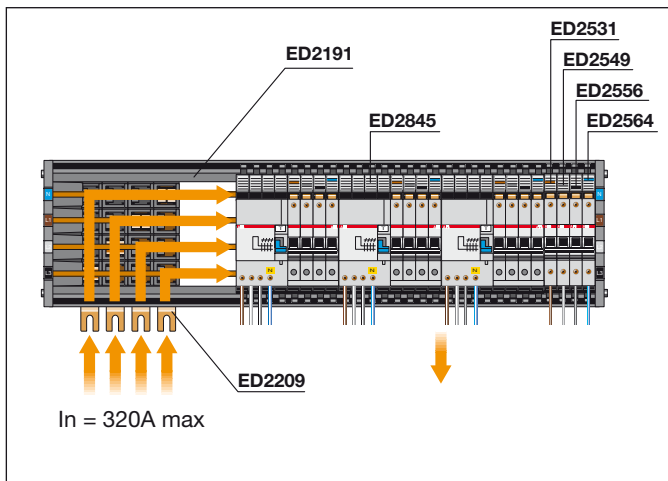

Busbar power supply from the bottom by means of main row circuit-breaker

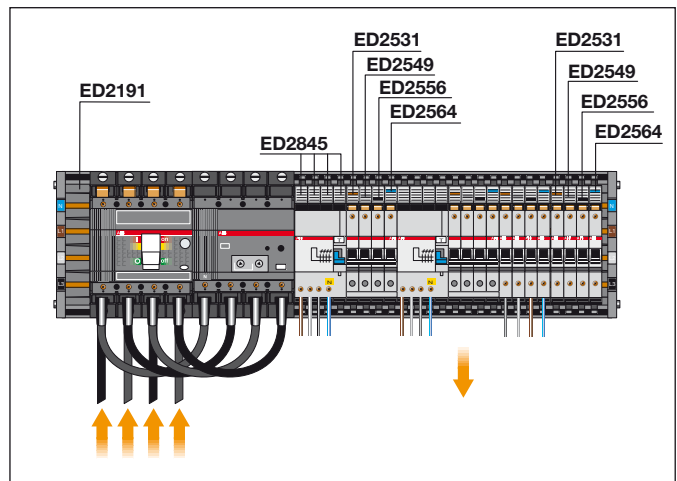

Busbar power supply from the top by means of 4P feeder module placed centrally

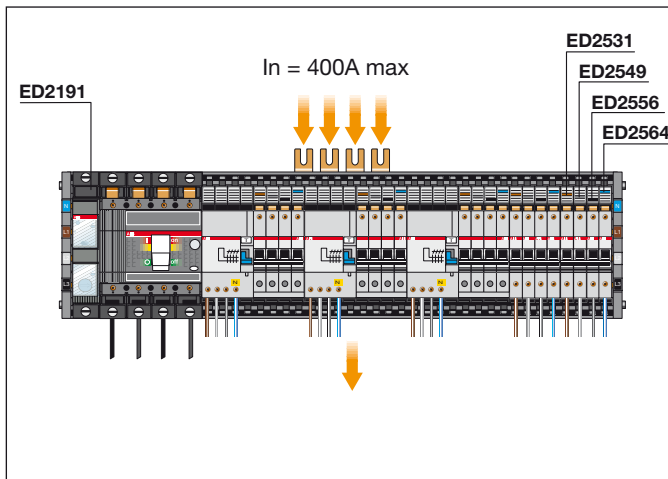

Covers for IP 20 degree of protection

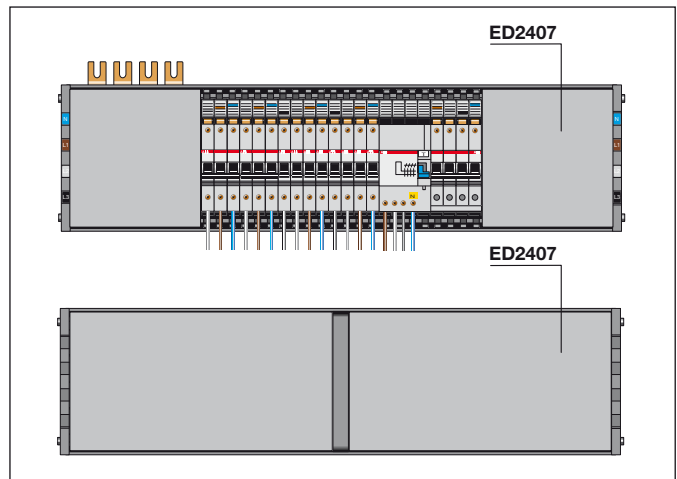

1STC862106F0001

Unifix cabling system

Examples of connections - Unifix H

Unifix L frame with 100A 12/18/24 module busbars

Two different single-phase circuits on a single 24 module DIN rail

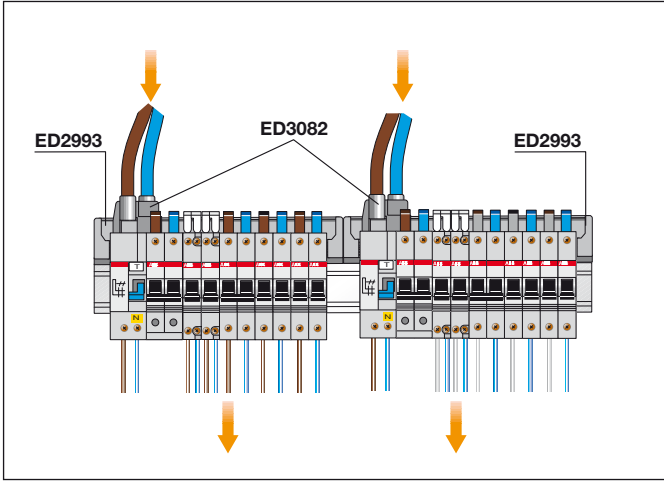

Example of main and shunted power supply

Unifix L frame with 100A 12/18/24 module busbars

Busbar power supply by means of power supply terminals placed centrally

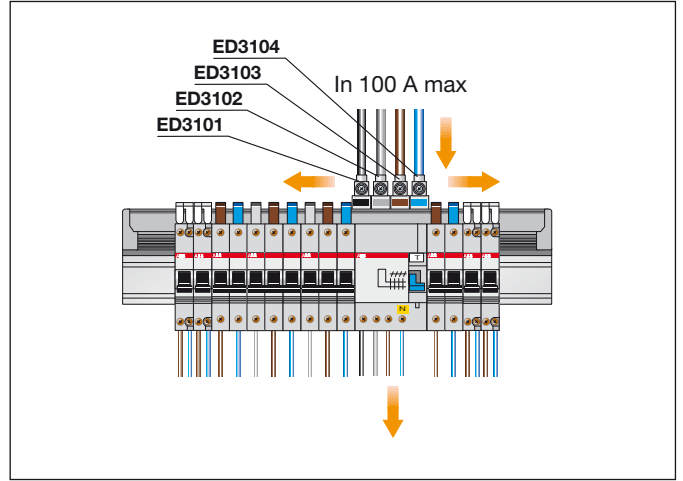

Busbar power supply by means of power supply terminals placed laterally

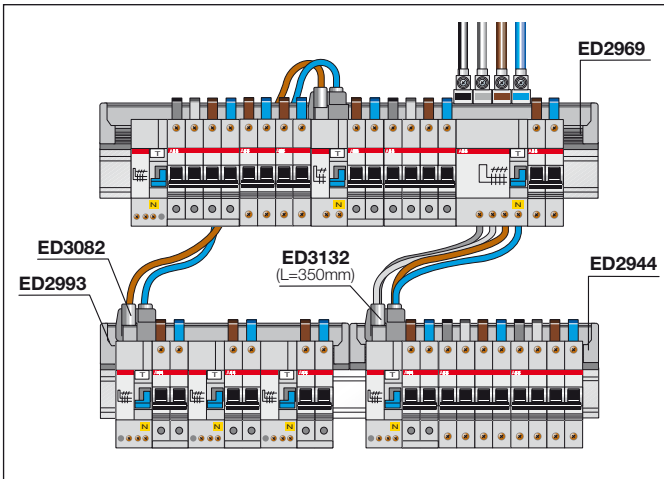

Busbar power supply by means of cable terminal placed under the head of the circuit-breaker terminal and branch with parallel module

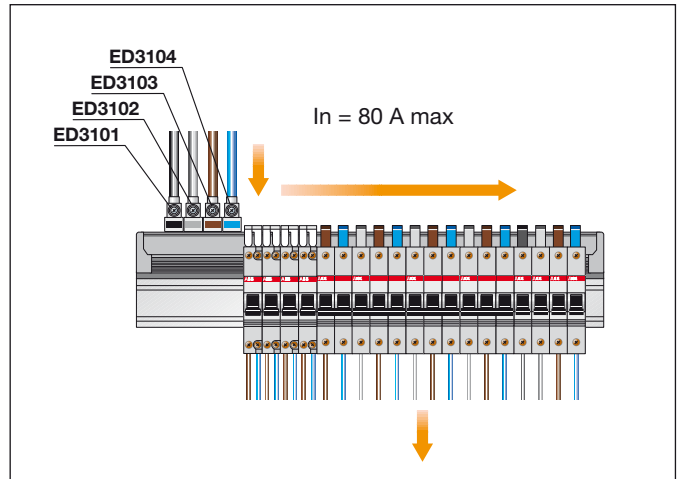

Direct busbar power supply by means of feeder module (supplied without cables) and branch by means of feeder module.

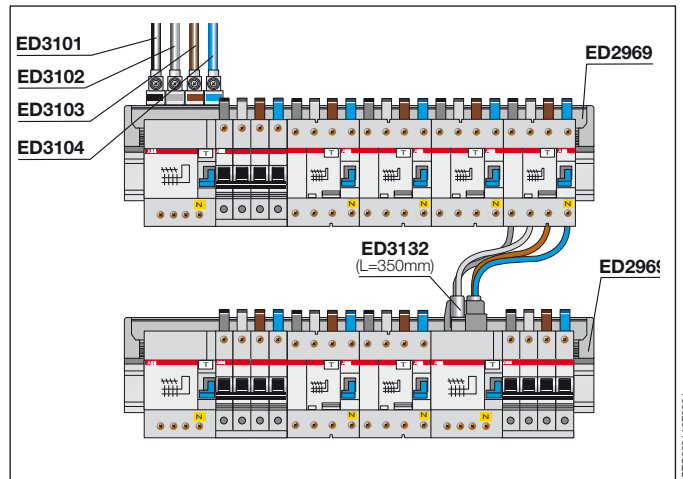
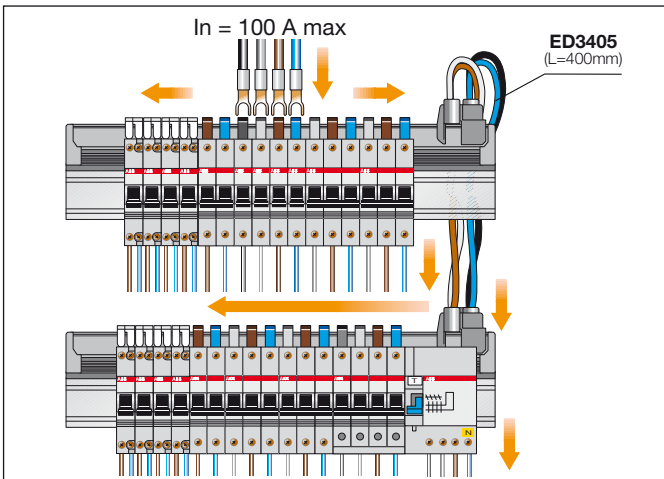

Segregations

Examples of ArTu segregation

Form 1
(no internal segregation)

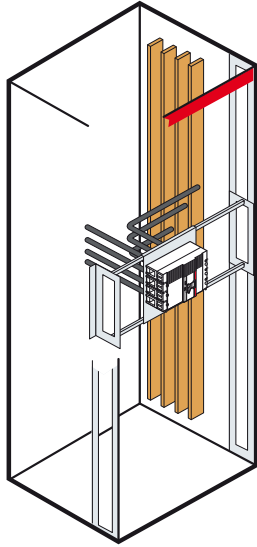

Form 3
(separation of the busbars from the functional units + separation of the functional units from each other)

Form 3a
Terminals not separated from the busbar

Form 3b
Terminals separated from the busbar

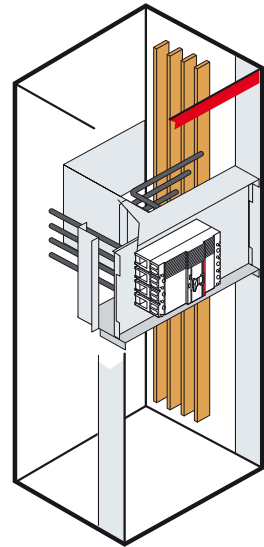

Form 2
(segregation of the busbars from the functional units)

Form 2a
Terminals not separated from the busbar

Forma 2b
Terminals separated from the busbar

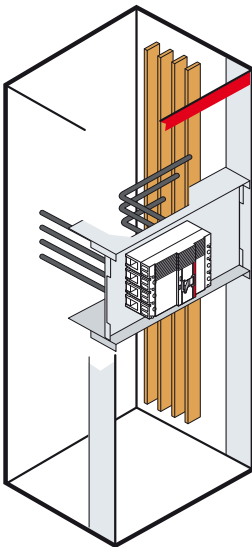

Form 4
(separation of the busbars from the functional units + separation of the functional units from each other + separation of the terminals from each other)

Form 4a
Terminals in the same the associated functional unit

Form 4b
Terminals not in the same the associated functional unit

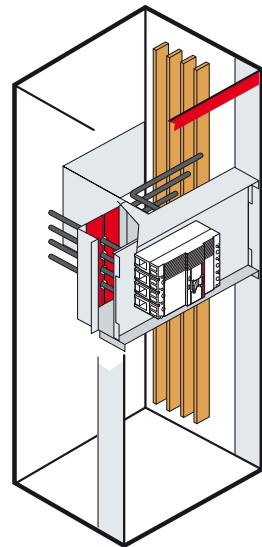

15T1C802070F0901



Index

T.C.T. (Technical Collection Tools)	7/3
Instruction manuals.....	7/4
Training: an essential tool for professionals.....	7/5
Business on line	7/5

Configurazione semiautomatica della carpenteria

Kvava cavi 2000x200x800 IP41

in - Modulo di calcolo sovratemperature nei quadri elettrici

- 1 Selezione componenti
- 2 Selezione struttura
- 3 Configuratore grafico
- 4 Preventivazione



Dati tecnici



Offerta

Design

Dimensioni

ABB DMSWin - Modulo | ABB DMSWin - Modul. | 12:21 PM

Pannello | Pagine 1

ABB Win3 | Atu

Selection and design tools

TCTWin 4.6 - Technical Collection Tools

The new 4.6 version of ABB Sace's TCTWin includes seven very useful pieces of technical software which make calculations, design and estimates easier, ensuring conformity of the installations with the Standards and reducing the risk of errors. It is also provided with ABB Software Desktop which, apart from being a useful console for launching all the software in the collection, allows access



to a series of convenient and practical functions which, over time, are enriched by updating via Internet. In fact, all the software can be updated over the net with just a simple click: the most convenient, simple and safe way to have the novelties ABB Sace makes available for professionals always to hand.

The software, collected on CD-Roms in a practical box, consists of the following:

DOC 1.0, for sizing electrical networks powered with low or medium voltage, offers: design and definition of the network, network calculations, conductor sizing, selection and coordination of switching and protection devices, representation of the curves, checks, printout of diagrams, diagrams and reports;

DMBWin 4.6, structured in interconnected modules which allow the project to be developed and to prepare the estimate for ABB Sace's ArTu and Gemini switchgear. It supports the user, from selection of the apparatus and metalwork structures, to designing the front of the switchgear, from making the estimate to documentation of the offer;

SPECs 1.3, to produce the specifications regarding the electrical installations of business structures, hotels, schools, hospitals, tunnels, garages, tourist ports, public entertainment rooms and other environments, constantly updated by means of an automatic procedure. With the internal text processor, it allows personalisation of the specifications and their exportation in the most commonly used text formats;

CAT 6.0, allows a product among the 25000 ABB Sace codes to be found and fitted with accessories, enriching the module for producing offers with management of discounts and mark-ups, personalised archives and detailed printouts;

PICOWin 3.0, to make out specifications and estimates for any civil, service sector or small industry electrical installation. It develops projects on layouts relative to lighting points, sockets, lamps, switches, and distribution channels, and allows configuration of control boxes (front and single-line) with ABB Sace apparatus up to 125A;

Prosoft 3.0, dedicated to selection of the PSS and PST stepped starters. Once the load and ABB motor have been selected, the programme selects the most suitable soft starter, taking into consideration the current, the torque and the start-up time;

DriveSize 2.9, allows the optimal motor, frequency converter and transformer solution to be defined, especially when selection from a catalogue is not possible. It can also be used to calculate current and network harmonic values and to create documents relative to sizing on the basis of the effective load.

Viewer 2.2, Viewer is the software that let you navigate and use all the documentation relating to ABB products, as catalogues, technical documentations, certificates and 2D - 3D dimensional drawings. All the files are at your disposal with few mouse click for reading and printing.



Some Screenshots of the DMBCab and DMBWin for the design of automation or distribution switchboards and for the configuration of ArTu distribution switchboards.

Selection and design tools

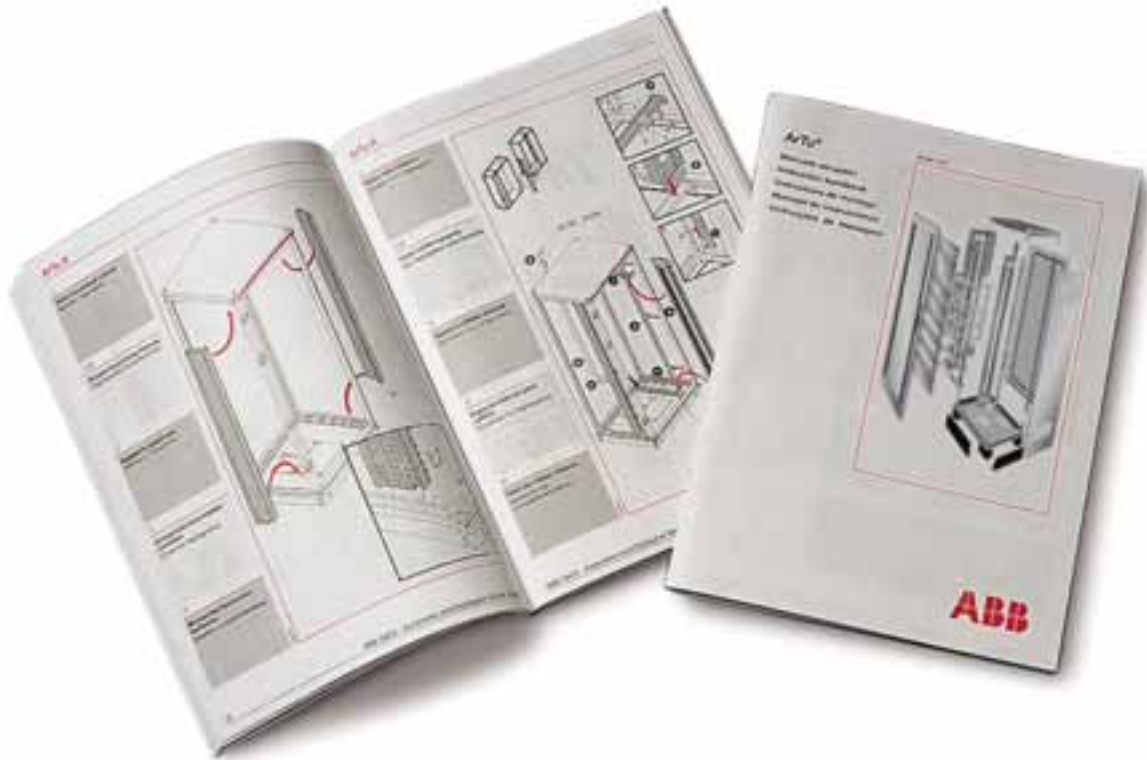

Instruction Manuals

The three multilingual instruction manuals, one for each series of switchboard, with overall and detailed drawings, indicate correct assembly of the metal structure and of the components inside it. They also contain cross references to article codes and the page number for easier and faster consultation.

Compliance with the indications given by the manufacturer allow electric switchboards of type AS to be correctly selected and assembled, complying with the EN 60439-1 Standard and with the new IEC 61439-1-2 Standard, based on what is foreseen by the European Community Low voltage Directive (Directive 2006/95/CE ex 73/23/CEE and subsequent amendments, Law 791/1977).

Selection and design tools

Training: an essential tool for professionals

ABB SACE makes the experience it has gained in more than 60 years' of activity available by means of technical training courses, which is an occasion for being brought up to date and comparing notes with expert professionals for all the operators in the sector. The aim is to meet all the requirements for information professionals may have, converting the technical-standard and legislative concepts into practical terms which can be applied directly to the different products and installations: in particular, the Tur1 (introductory) and Tur2 (advanced) courses, reserved for switchgear experts, installers and designers, aim at illustrating the procedure for designing and constructing low voltage switchgear on the basis of the CEI Standards and European Community Directives in force.



Business on line (<http://bol.it.abb.com>) is the portal created by ABB SACE to provide its customers with a work tool built around the requirements of professionals, offering an innovative approach to the world of low voltage electrical installations and industrial automation. By means of guided paths or by choosing free navigation, each user can easily reach the information wanted.

Work tools

All the tools needed to make your daily work easier can be found on line: estimates and designing complex installations, software to select and correctly size motors and actuators, specific interactive catalogues for home automation and selection of the Élos wiring accessories series... and still a lot more.

Guided paths

The "guided paths" which you can access from the home page facilitate navigations among ABB SACE products:

- Electrical distribution: particularly dedicated to those who design and install low voltage installations in the industrial and in the medium-to-large-sized service sector;
- Civil and service sector installation: ABB SACE's offer for installations in the residential and small service sectors;
- Automation and control: actuators, motors and control and protection apparatus for all industrial applications on machines and plants;
- Process measuring sensors: ABB's whole vast range of field instruments for industrial processes;
- Home and building automation, i.e. the most advanced solutions for integrated automation and management of buildings and home and service sector environments, as well as those of particular historical and artistic value.

Using the guided paths, centred on the product and its use, it is easy to orientate yourself among the offer of apparatus and systems which interest you and to find all the relevant information and work material: catalogues, certificates, and design tools.

"Smart catalogue"

This is a virtual catalogue on line which, by means of selecting the technical characteristics, allows you to find each individual product rapidly and easily. Product cards and family cards are available with detailed descriptions and all the relative documentation. The cards can be printed and filed on your own PC so that you can consult the data at any time.

"My Documentation"

A personalized collection of documents can be created: "My Documentation" allows you to add all the documentation you like to your own library, saving the documents you are interested in to a personalized directory to be able to use them again whenever needed. A registered user can check for any updates in the material in his own library, display the document, print it, or order the paper version. You must login to be able to use this function.

Customer Care

The new Customer Care Service which allows specific and in-depth information to be obtained on subjects of interest in a rapid and competent way by filling in a form

New Search Engine

The new search engine allows advanced type searches, by means of the "FILTER THE RESULTS FOR" section.





Overall dimensions

Index

Gemini	8/2
ArTu L	8/6
ArTu M	8/10
ArTu K	8/14
ArTu L - M - K - Kit for apparatus	8/19
ArTu L - M - K - Distribution systems	8/21

Gemini

Overall dimensions

Structures

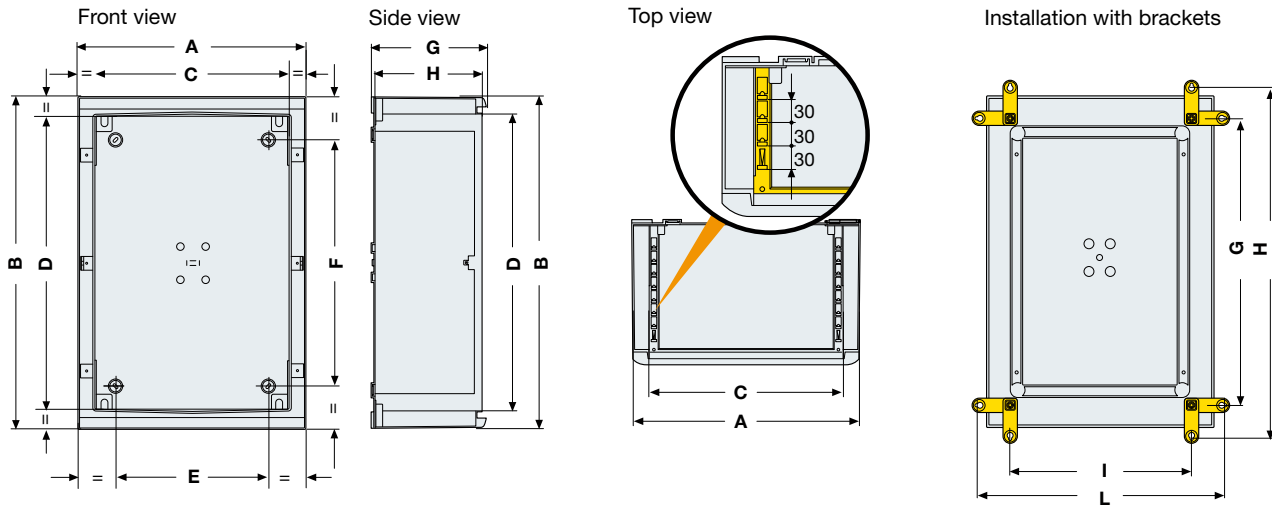

Side	Code	A	B	C	D	E	F	G	H	I	L
1	1SL0201A00-1SL0211A00-1SL0221A00	335	400	250	300	150	180	263	463	195	395
2	1SL0202A00-1SL0212A00-1SL0222A00	460	550	375	450	250	270	412	612	320	520
3	1SL0203A00-1SL0213A00-1SL0223A00	460	700	375	600	270	475	560	760	320	520
4	1SL0204A00-1SL0214A00-1SL0224A00	590	700	500	600	286	385	562	762	445	645
5	1SL0205A00-1SL0215A00-1SL0225A00	590	855	500	750	390	558	713	913	445	645
6	1SL0206A00-1SL0216A00-1SL0226A00	840	1005	750	900	640	706	863	1063	695	895

Uprights

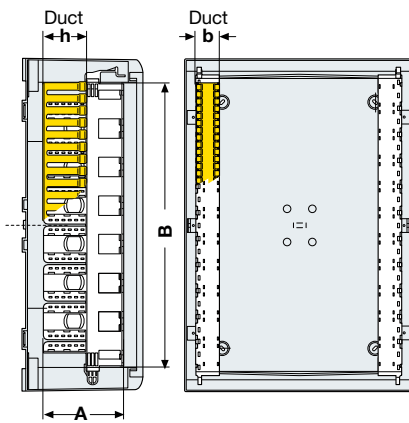

Size	Code	A	B	b	h
1	1SL0283A00	132	300	18	46
2	1SL0284A00	152	450	27	46
3	1SL0285A00	152	600	27	46
4	1SL0285A00	152	600	27	46
5	1SL0286A00	152	750	36	46
6	1SL0287A00	152	900	55	46

Front opaque and transparent doors

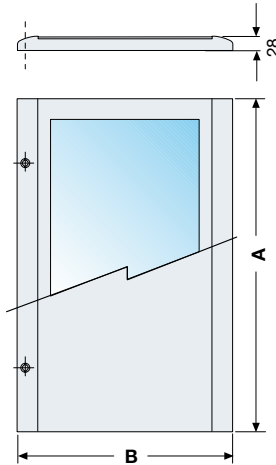

Size	Code	A	B
1	1SL0241A00-1SL0231A00	349	325
2	1SL0242A00-1SL0232A00	499	450
3	1SL0243A00-1SL0233A00	649	450
4	1SL0244A00-1SL0234A00	649	575
5	1SL0245A00-1SL0235A00	799	575
6	1SL0246A00-1SL0236A00	949	825

The measurements are in millimetres

1SLCR65007F0601

Gemini

Overall dimensions

Base plates

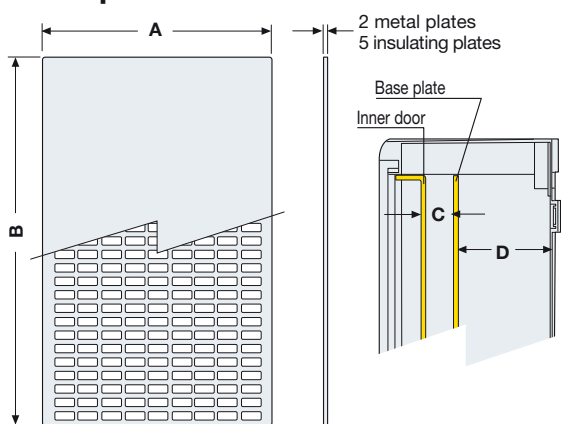

Size	Code	A	B	C	D
1	1SL0259A00-1SL0275A00-1SL0267A00	235	285	33.5±110	16.3±91
2	1SL0260A00-1SL0276A00-1SL0268A00	360	435	33.5±139	36.4±140
3	1SL0261A00-1SL0277A00-1SL0269A00	360	585	33.5±139	36.4±140
4	1SL0262A00-1SL0278A00-1SL0270A00	485	585	33.5±139	36.4±140
5	1SL0263A00-1SL0279A00-1SL0271A00	485	735	33.5±228	47±244
6	1SL0264A00-1SL0280A00-1SL0272A00	735	885	33.5±228	47±244

Inner doors

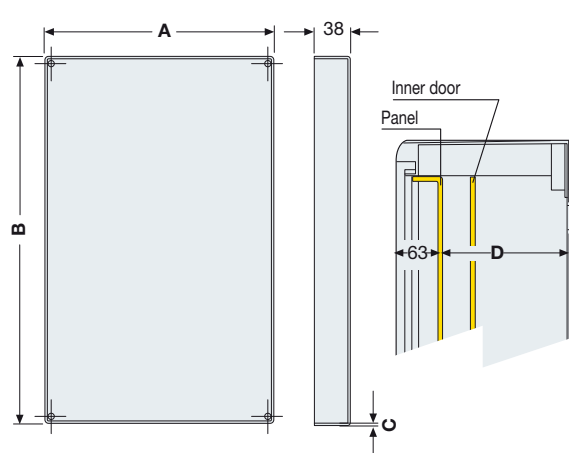

Size	Code	A	B	C	D
1	1SL0251A00	250	300	3	128
2	1SL0252A00	375	450	4	177
3	1SL0253A00	375	600	4	177
4	1SL0254A00	500	600	4	177
5	1SL0255A00	500	750	5	277
6	1SL0256A00	750	900	5	277

DIN rail

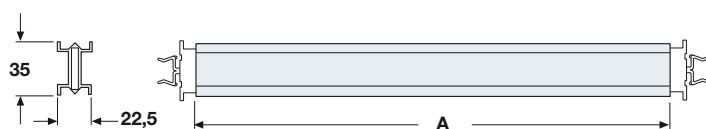

Size	Code	A	d = pos. 1	d = pos. 2	d = pos. 3	d = pos. 4	d = pos. 5	d = pos. 6
1	1SL0290A00	210	51	63,5	76	88,5	-	-
2	1SL0291A00	318	51	63,5	76	88,5	101	113,5
3	1SL0291A00	318	51	63,5	76	88,5	101	113,5
4	1SL0292A00	443	51	63,5	76	88,5	101	113,5
5	1SL0292A00	443	51	63,5	76	88,5	101	113,5
6	1SL0293A00	663	51	63,5	76	88,5	101	113,5

The distances of the DIN rail from the panel depend on the depth at which the DIN rail is regulated by using fixing devices.

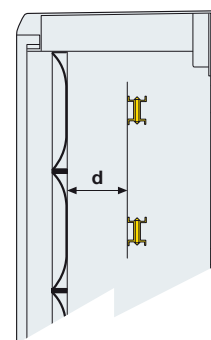

Panels for modular apparatus mounted on DIN rail

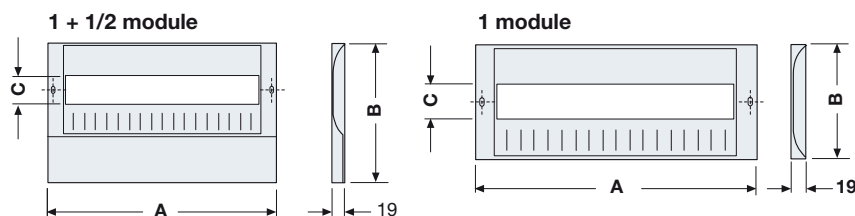

Size	Code	1 mod.		1+1/2 mod.		C	DIN modules		
		A	B	A	B		d	f	
1	1SL0307A00	250	150	-	-	46	12	44	145
2	1SL0308A00-1SL0313A00	375	150	375	225	46	18	44	197
3	1SL0308A00-1SL0313A00	375	150	375	225	46	18	44	197
4	1SL0309A00-1SL0314A00	500	150	500	225	46	24	44	197
5	1SL0309A00-1SL0314A00	500	150	500	225	46	24	44	297
6	1SL0310A00-1SL0315A00	750	150	750	225	46	36	44	297

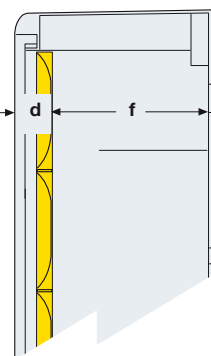

The measurements are in millimetres

1SL025608F001

Gemini

Overall dimensions

Blank panels

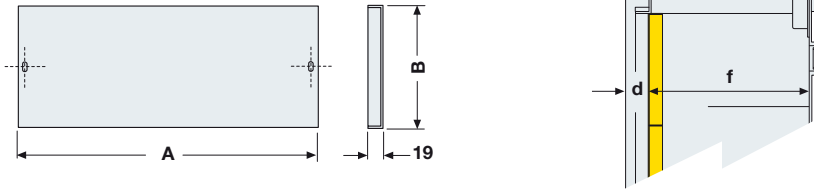

Size	Code	1/2 mod.		1 mod.		2 mod.		d	f
		A	B	A	B	A	B		
1	1SL0318A00-1SL0324A00-1SL0330A00	250	75	250	150	250	300	26,5	162
2	1SL0319A00-1SL0325A00-1SL0331A00	375	75	375	150	375	300	26,5	214
3	1SL0319A00-1SL0325A00-1SL0331A00	375	75	375	150	375	300	26,5	214
4	1SL0320A00-1SL0326A00-1SL0332A00	500	75	500	150	500	300	26,5	214
5	1SL0320A00-1SL0326A00-1SL0232A00	500	75	500	150	500	300	26,5	314
6	1SL0321A00-1SL0327A00-1SL0233A00	750	75	750	150	750	300	26,5	314

Modular plates

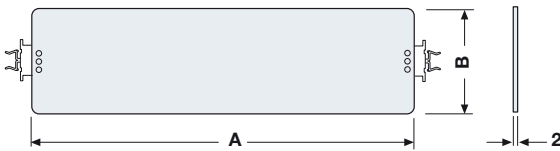

Size	Code	1 mod.		2 mod.	
		A	B	A	B
1	1SL0296A00	210	130		
2	1SL0297A00-1SL0302A00	318	130	318	280
3	1SL0297A00-1SL0302A00	318	130	318	280
4	1SL0298A00-1SL0303A00	443	130	443	280
5	1SL0298A00-1SL0303A00	443	130	443	280
6	1SL0299A00-1SL0304A00	663	130	663	280

Mounting distances between front panel and plate

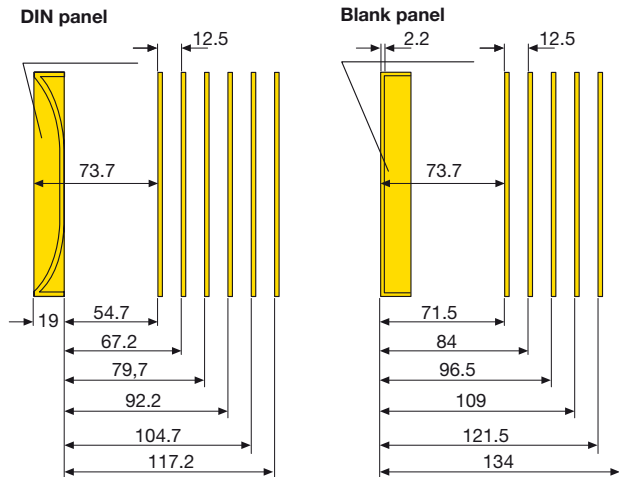

Kit for Tmax

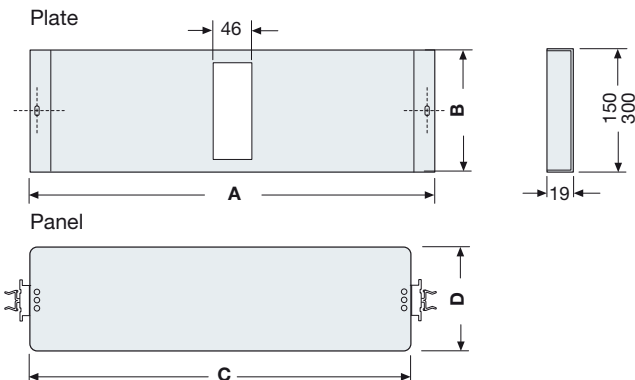

Size	Code	1 mod.		2 mod.	
		A	B	A	B
2	1SL0336A00-1SL0370A00	375	150	375	300
3	1SL0336A00-1SL0370A00	375	150	375	300
4	1SL0337A00-1SL0371A00	500	150	500	300
5	1SL0337A00-1SL0371A00	500	150	500	300
6	1SL0338A00-1SL0372A00	750	150	750	300

Size	Code	1 mod.		2 mod.	
		C	D	C	D
1	1SL0296A00	210	130		
2	1SL0297A00-1SL0302A00	318	130	318	280
3	1SL0297A00-1SL0302A00	318	130	318	280
4	1SL0298A00-1SL0303A00	443	130	443	280
5	1SL0298A00-1SL0303A00	443	130	443	280
6	1SL0299A00-1SL0304A00	663	130	663	280

The measurements are in millimetres

1SLC065011F0901

Gemini

Overall dimensions

Coupling Kit

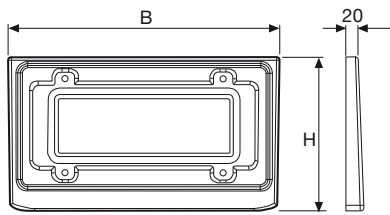

size	B	H
2	-	-
3	455	258
4	455	258
5	583	260
6	583	360
	834	360

Plinth

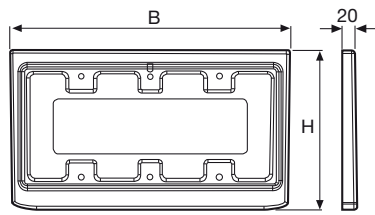

size	B	H
2	-	-
3	458	260
4	458	260
5	583	260
6	590	366
	840	366

Fixed frame

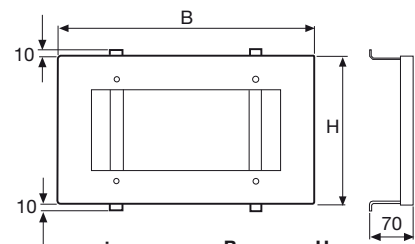

size	B	H
2	-	-
3	415	240
4	415	240
5	540	240
6	584	330
	834	330

Wiring kit

Duct 25x60 mm

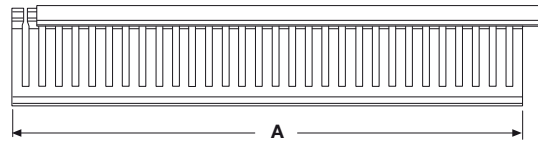
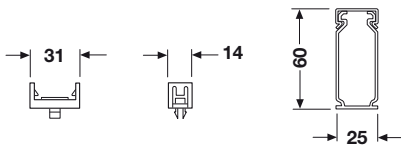

Duct 40x60 mm

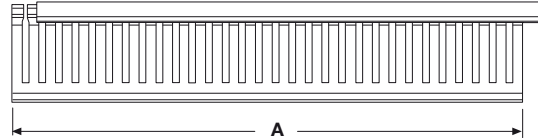
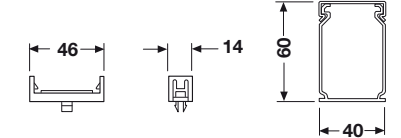

size	A
2	210
3	318
4	318
5	443
6	443
	663

Ventilation kit

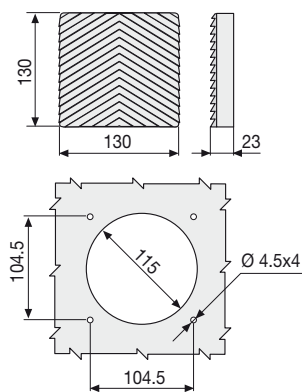

Anti-condensation kit

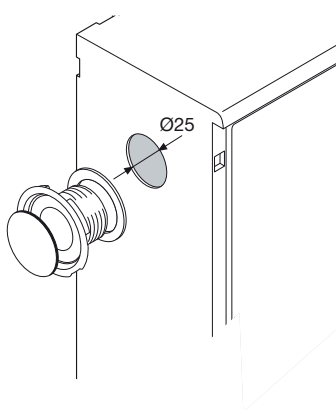

Pedestal

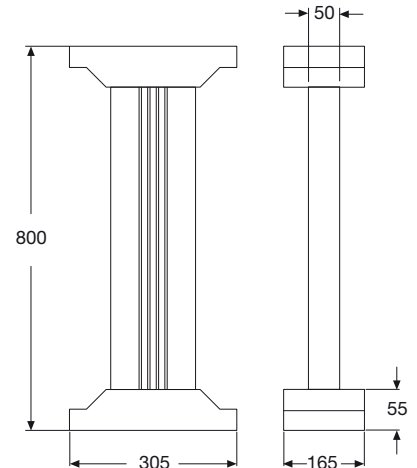

Pole installation kit

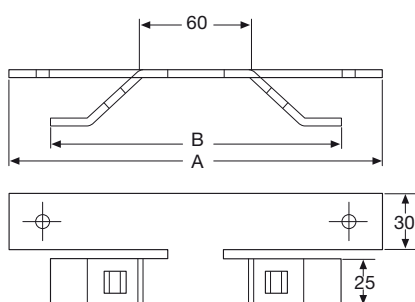

size	A	B
1	232	206
2-3	358	332
4-5	483	457
6	733	707

The measurements are in millimetres

ArTu L

Overall dimensions

Wall-mounted ArTu L

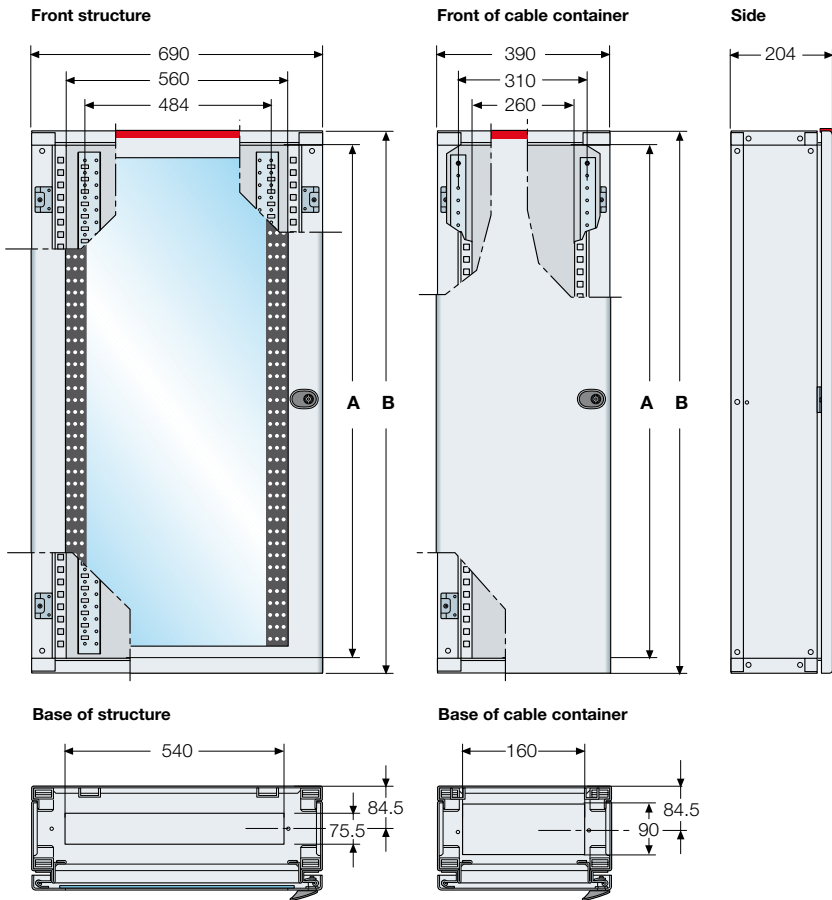

	A	B
Structure		
SL0600	600	650
SL0800	800	850
SL1000	1000	1050
SL1200	1200	1250
Cable container		
VC0600	600	650
VC0800	800	850
VC1000	1000	1050
VC1200	1200	1250

ArTu L

Overall dimensions

Wall-mounted ArTu L

Fixing to wall

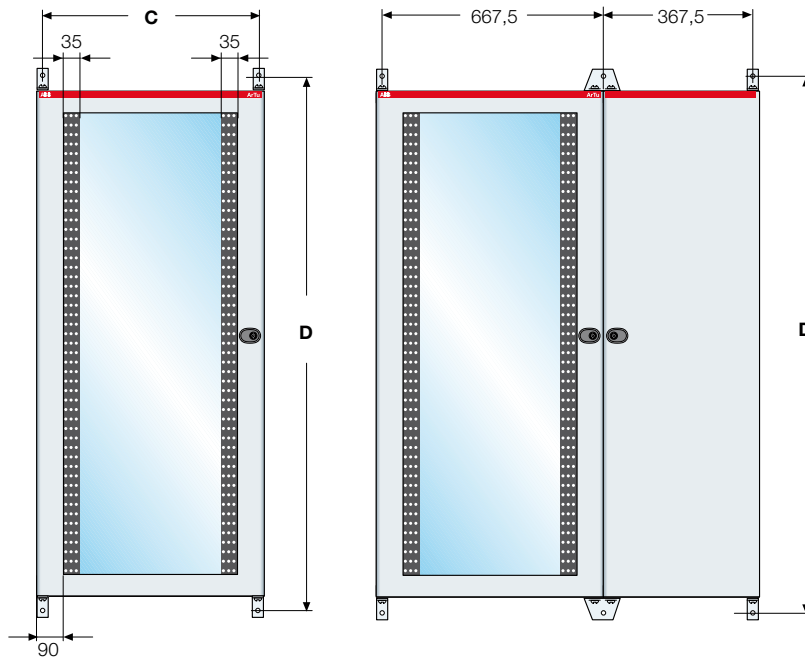

	C	D
Structure		
SL0600	645	700
SL0800	645	900
SL1000	645	1100
SL1200	645	1300
Cable container		
VC0600	345	700
VC0800	345	900
VC1000	345	1100
VC1400	345	1300

Useful space inside wall-mounted switchgear

Structure

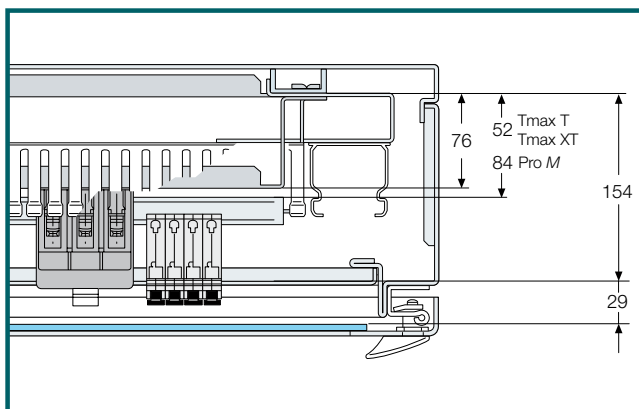

Cable container

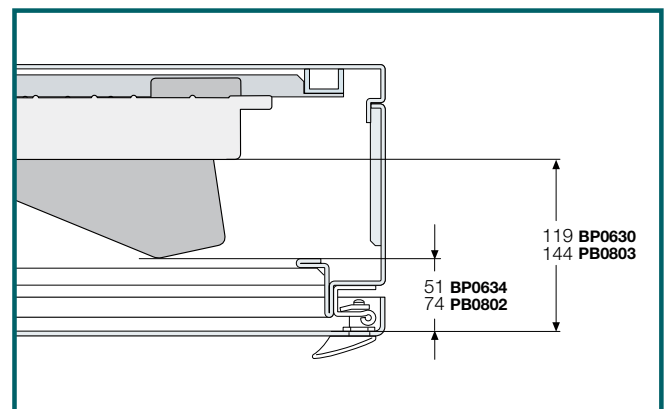

The measurements are in millimetres

1STC82076F0901

ArTu L

Overall dimensions

Floor mounted ArTu L

Front of structure

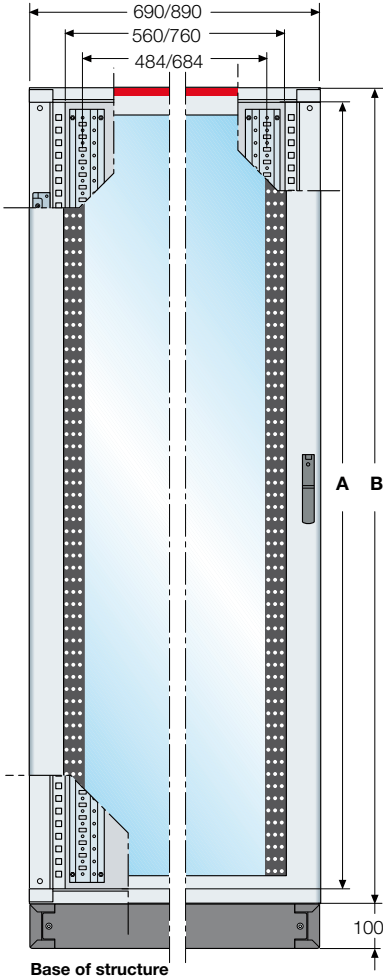

Base of structure

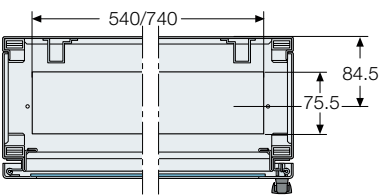

Front of structure with internal cable container

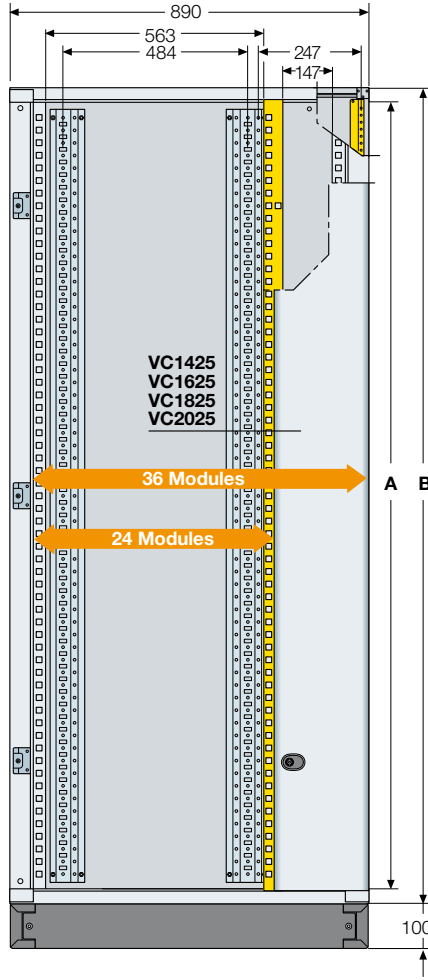

Structure	A	B
SL1400 - SL1408	1400	1450
SL1600 - SL1608	1600	1650
SL1800 - SL1808	1800	1850
SL2000 - SL2008	2000	2050

Front of external cable container

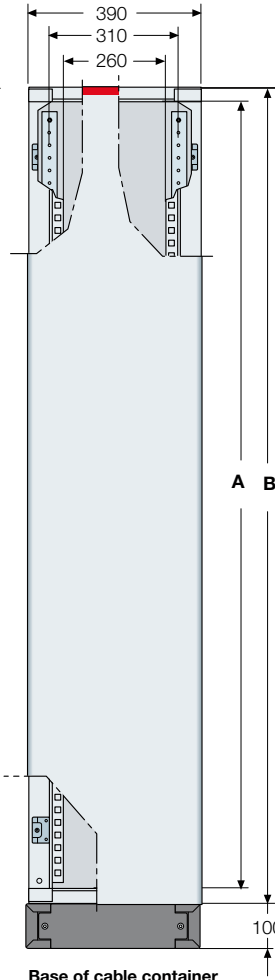

Base of cable container

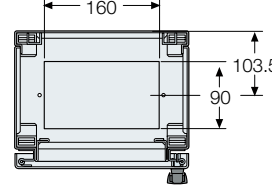

Side

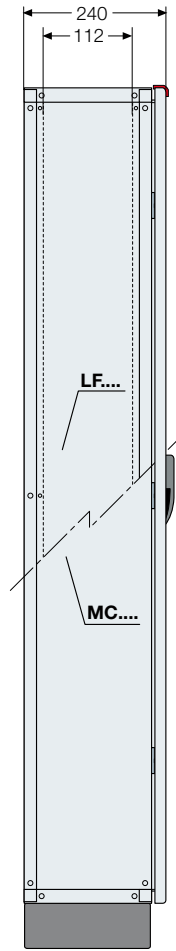

External cable container

External cable container	A	B
VC1400	1400	1450
VC1600	1600	1650
VC1800	1800	1850
VC2000	2000	2050

Cable connection box

Front view

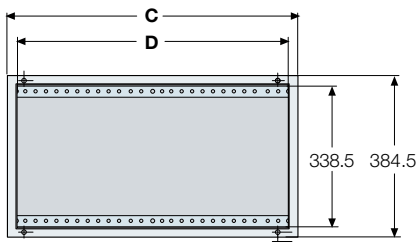

Top view

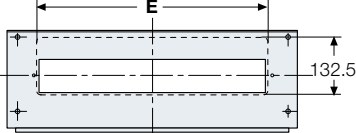

Side view

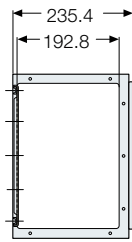

	C	D	E
Connection box for structure			
RC1000	690	644	550
Connection box for cable container			
RC2000	390	344	250

Pistre di fondo cieche

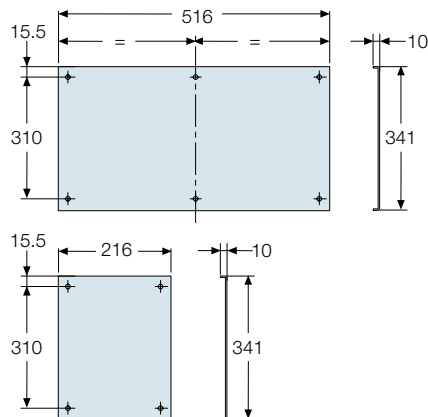

The measurements are in millimetres

ArTu L

Overall dimensions

Floor-mounted ArTu L

Fixing to wall/floor

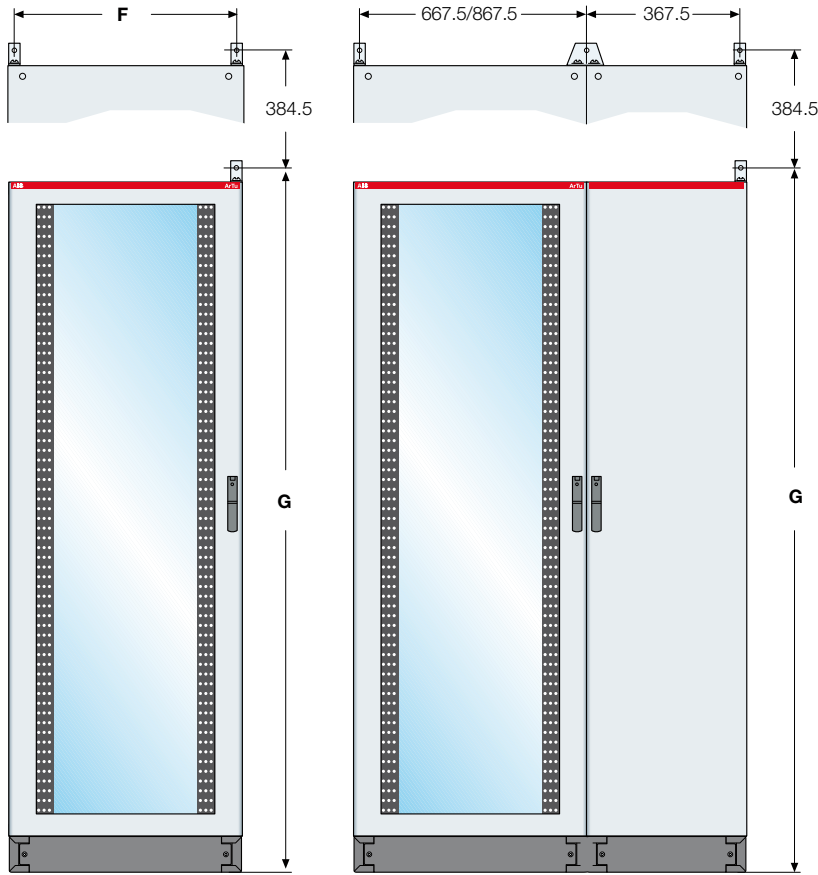

Glazed door 24 mod.
+ int. cable container

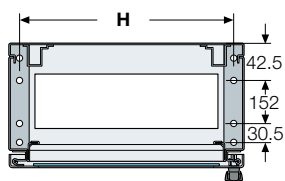
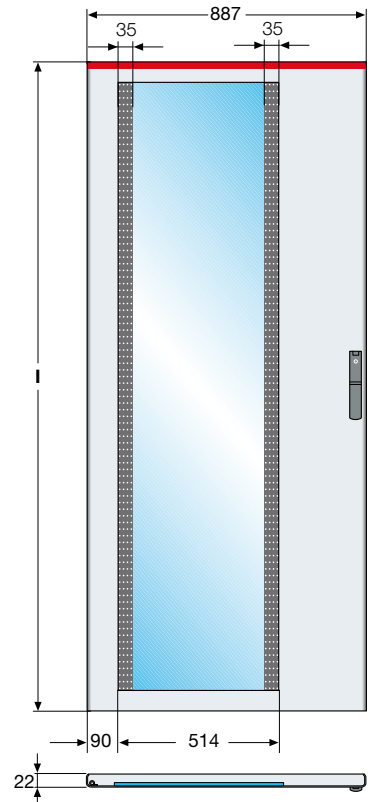

Structure	Structure				External cable container			
	F	G	H	I	F	G	H	
SL1400	645	1575	645		VC1400	345	1575	345
SL1600	645	1775	645		VC1600	345	1775	345
SL1800	645	1975	645		VC1800	345	1975	345
SL2000	645	2175	645		VC2000	345	2175	345
SL1408	845	1575	845	1436				
SL1608	845	1775	845	1636				
SL1808	845	1975	845	1836				
SL2008	845	2175	845	2036				

Useful space inside floor-mounted switchgear

Structure

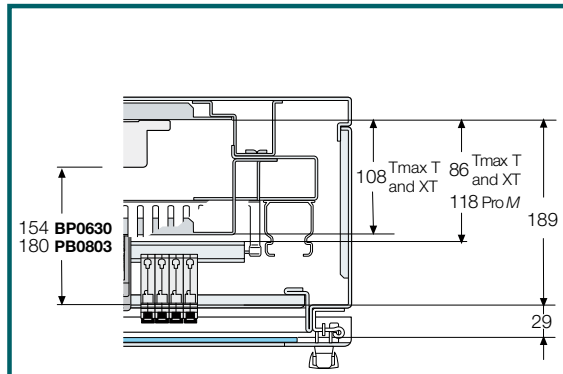

Cable container

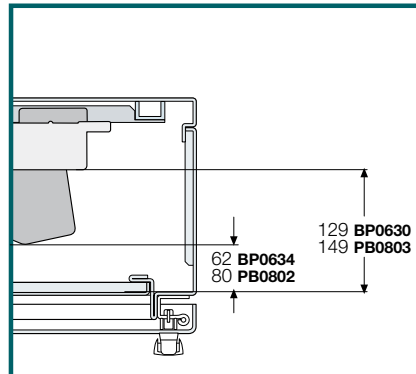

Connection box

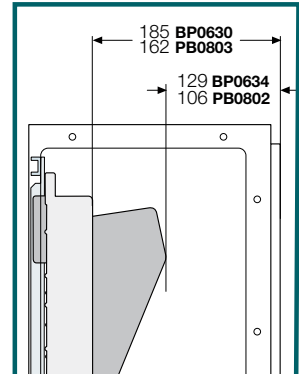

The measurements are in millimetres

1STC820278F0901

ArTu M

Overall dimensions

Wall-mounted ArTu M

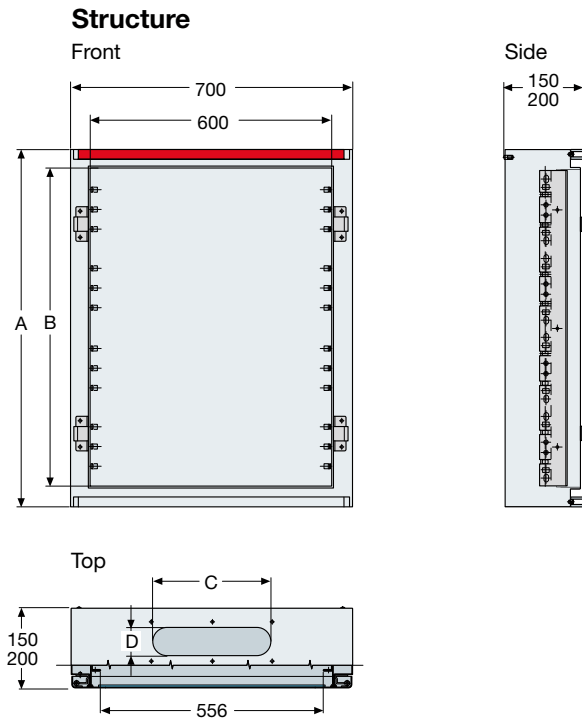

Blind or transparent front door

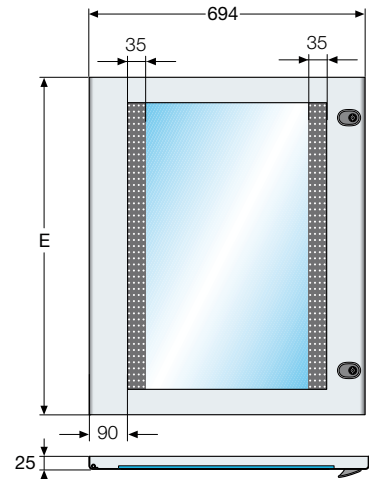

	A	B	C	D	E
Depth 150mm					
SM6061	700	600	183	60	640
SM8061	900	800	183	60	840
Depth 200mm					
SM8062	900	800	320	70	840
SM1062	1100	1000	320	70	1040
SM1262	1300	1200	320	70	1240

Switchgear for operating theatre SM 1069

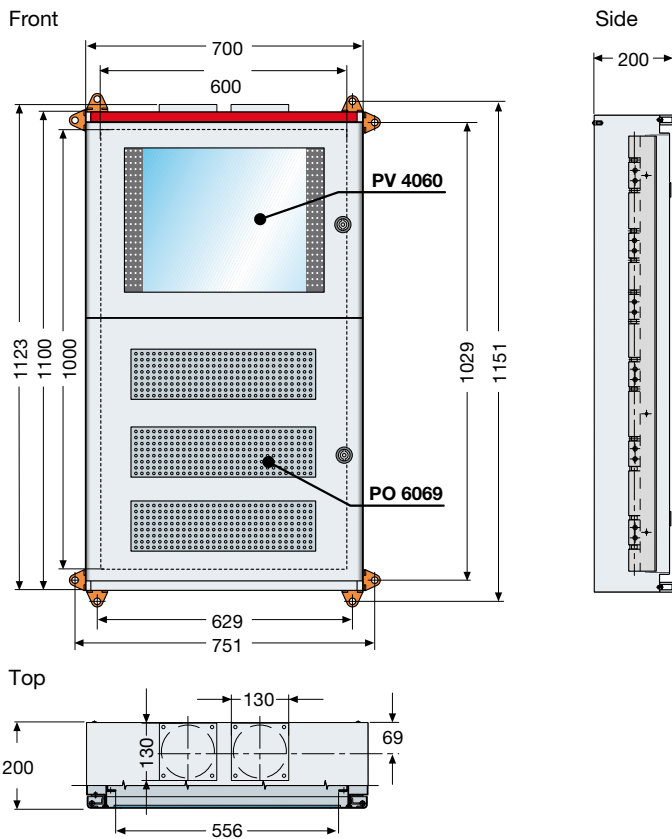

The measurements are in millimetres

ArTu M

Dimensioni di ingombro

Wall-mounted ArTu M

Fixing to wall

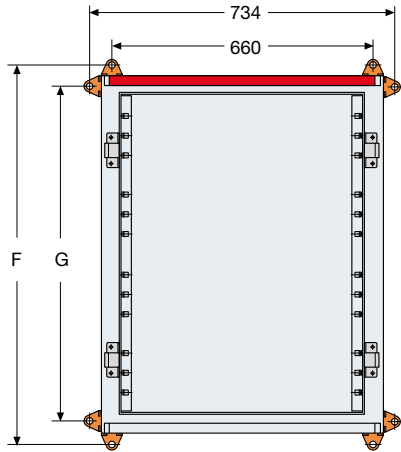

	F	G
Depth 150mm		
SM6061	734	661
SM8061	934	861
Depth 200mm		
SM8062	934	861
SM1062	1134	1061
SM1262	1334	1261

Embedded installation

Front

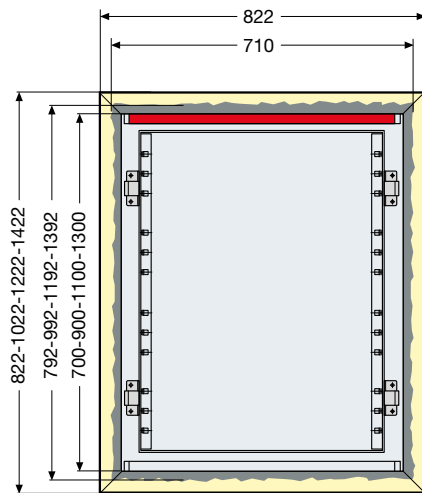

Totally embedded

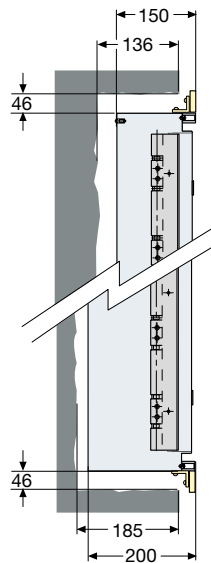

Semi-embedded

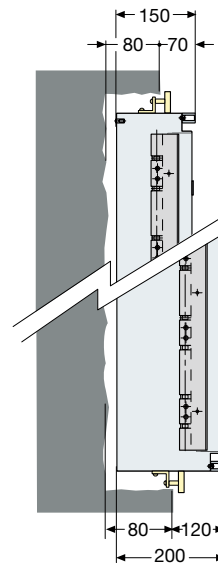

Useful space inside wall-mounted switchgear

Depth 150mm

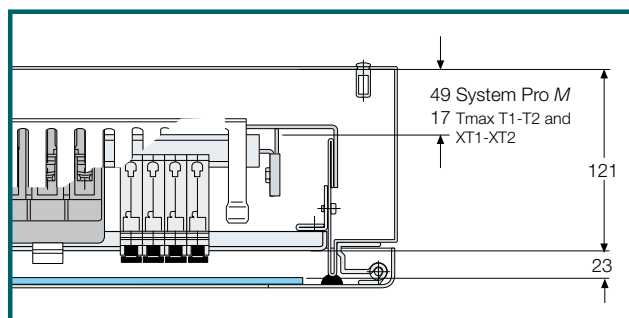

Depth 200mm

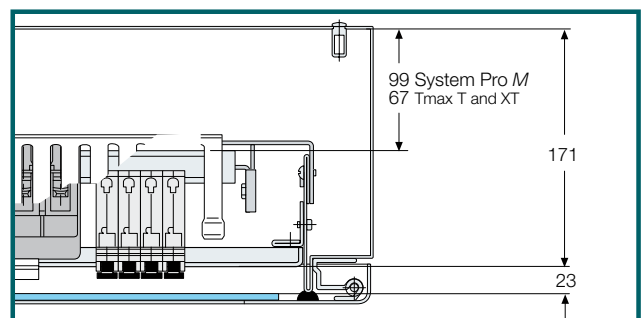

The measurements are in millimetres

1STC8202080F0301

ArTu M

Overall dimensions

Floor-mounted ArTu M

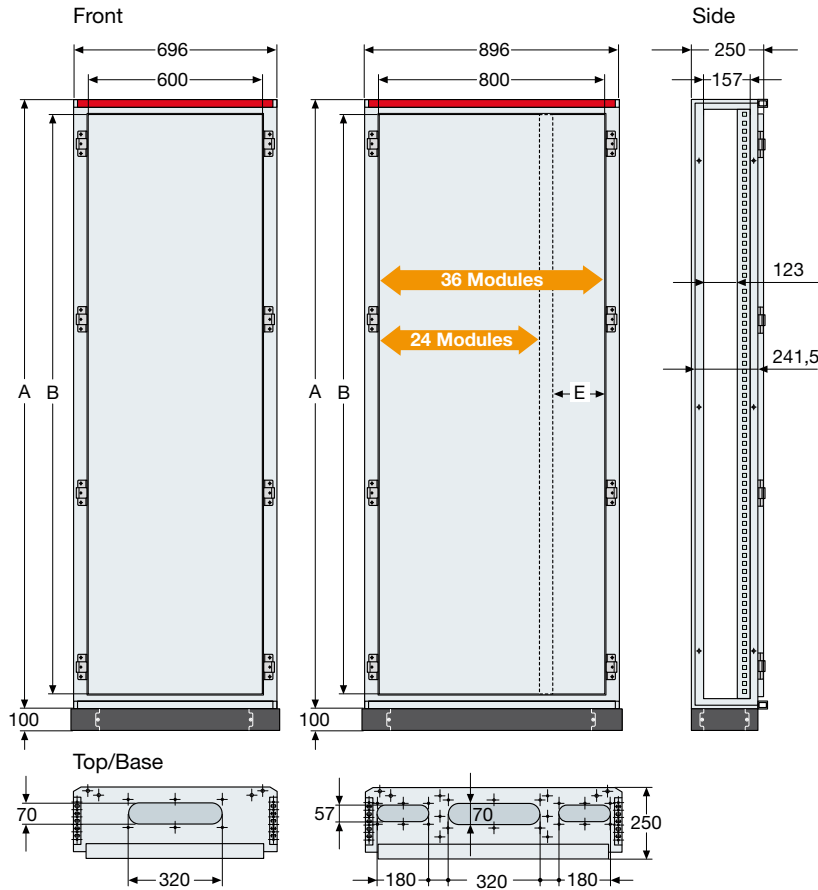

	A	B	C	D	E
Structures without cable container					
SM1462	1496	1400	1490	1436	
SM1662	1696	1600	1690	1636	
SM1862	1896	1800	1890	1836	
SM2062	2096	2000	2090	2036	
Structures with cable container					
SM1682	1696	1600	1690	1636	157
SM1882	1896	1800	1890	1836	157
SM2082	2096	2000	2090	2036	157
Additional cable container					
VC1632	1696	1600			
VC1832	1896	1800			
VC2032	2096	2000			

Overall dimensions for several structures side by side

$$W \times N + 28 = Xmm$$

W = Column width
 N = Number of columns
 28 = Overall dimensions 2 side panels

Blind or transparent front doors

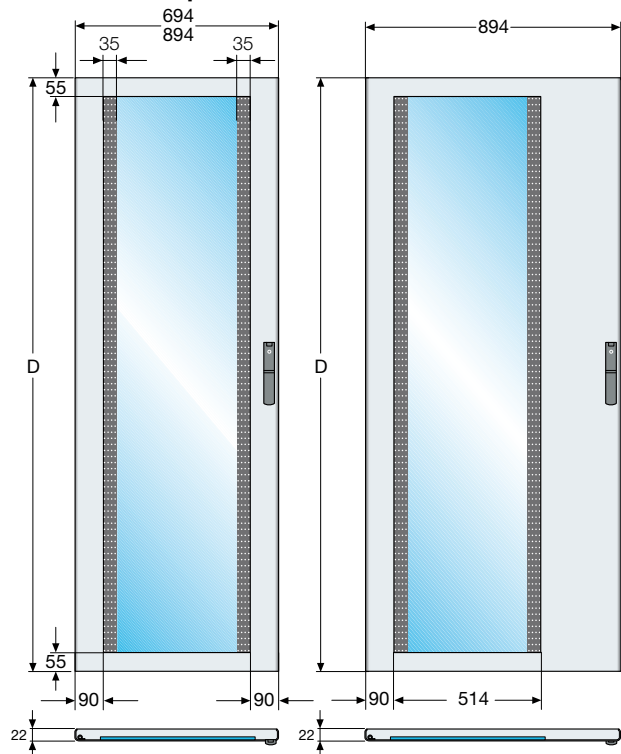

Side panel

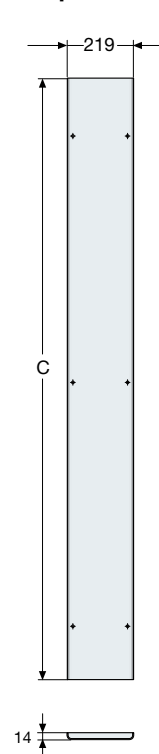

Additional cable container

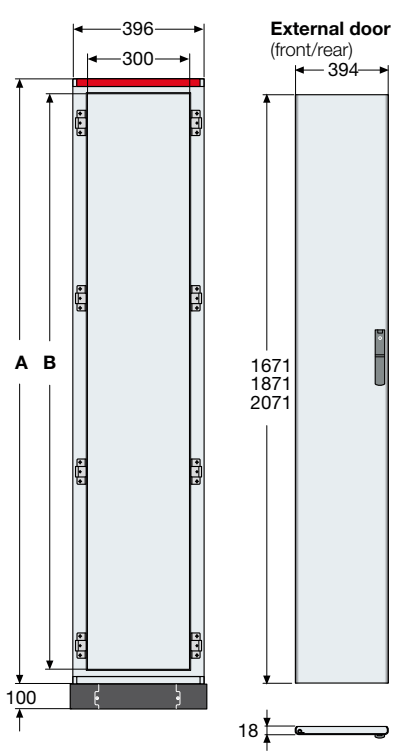

The measurements are in millimetres

ArTu M

Overall dimensions

Floor-mounted ArTu M

Fixing to wall/floor

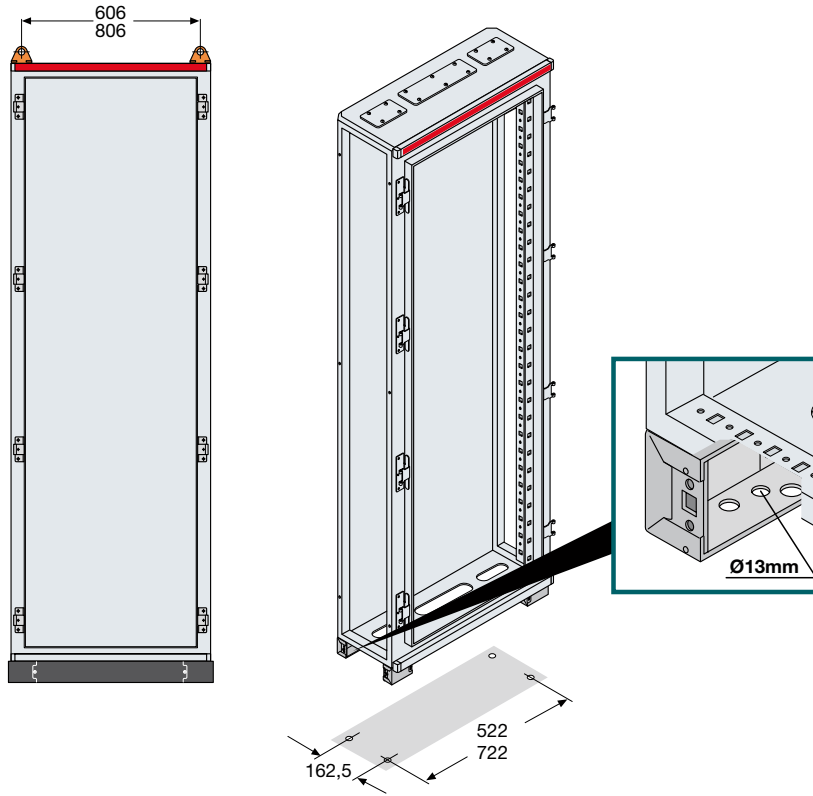

Useful space inside floor-mounted switchgear

	F	G	H	I
System Pro M	72	129,5	120 max	81
Tmax T1-T2			78	108
Tmax XT1-XT3			74	112
Tmax XT2-XT4			86	124

Structure

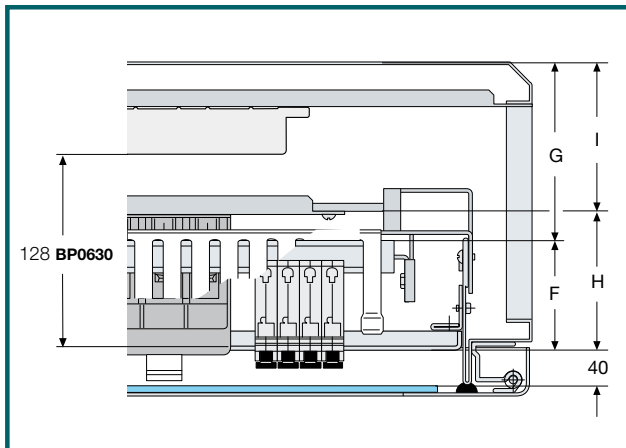

Cable container

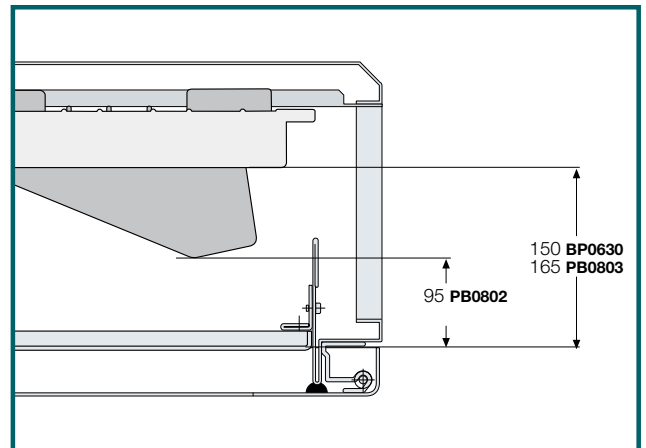

The measurements are in millimetres

ArTu K

Overall dimensions

ArTu K

Structure without cable container

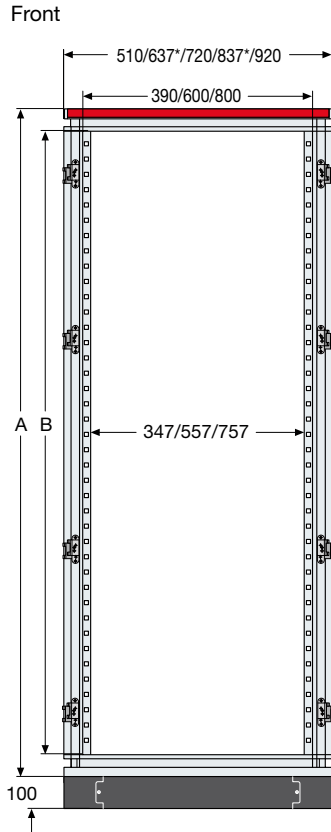

Structure with cable container

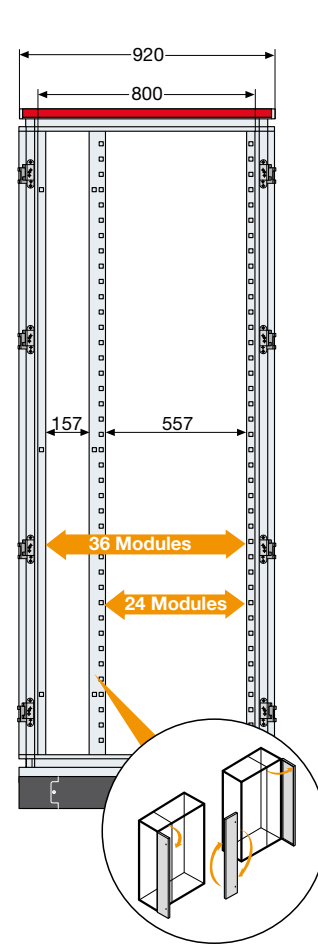

Side D ≤ 300mm

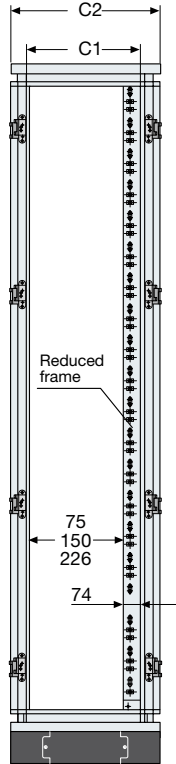

Side P ≥ 500mm

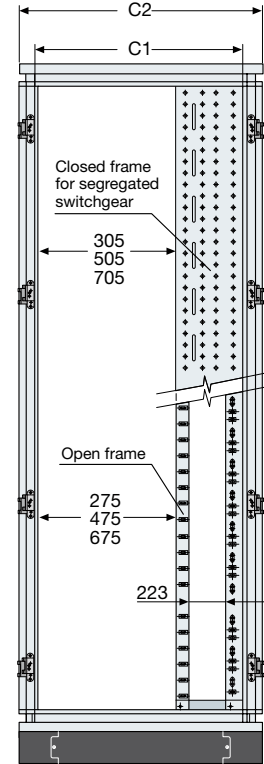

Structure height 1600mm

	A	B	C1	C2
SK6025/SK8025	1731	1600	150	270

Structure height 1800mm

	A	B	C1	C2
SK6025/SK8025	1931	1800	150	270
SK4040/SK6040/SK8040	1931	1800	225	345
SK4050/SK6050/SK8050	1931	1800	300	420
SK4060/SK6060/SK8060/SK6600*	1931	1800	500	620
SK4080/SK6080/SK8080/SK8800*	1931	1800	700	820
SK4010/SK6010/SK8010	1931	1800	900	1020

Structure height 2000mm

	A	B	C1	C2
SK6025/SK8025	2131	2000	150	270
SK4040/SK6040/SK8040	2131	2000	225	345
SK4050/SK6050/SK8050	2131	2000	300	420
SK4060/SK6060/SK8060/SK6600*	2131	2000	500	620
SK4080/SK6080/SK8080/SK8800*	2131	2000	700	820
SK4010/SK6010/SK8010	2131	2000	900	1020

* Angled structures

Overall dimensions for several structures side by side

$$W \times N + 28 = X \text{mm}$$

W = Column width

N = Number of columns

28 = Overall dimensions 2 side panels

The measurements are in millimetres

ArTu K

Overall dimensions

Bases

SK6025 (W600xD150)
SK8025 (W800xD150)
VC3025 (W300xD150)

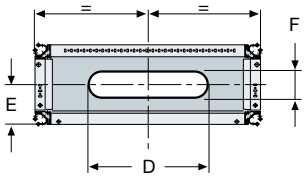

SK4040 (W390xD225)
SK6040 (W600xD225)
VC3040 (W300xD225)

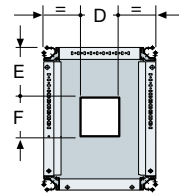

VC3060 (W300xD500)
VC3080 (W300xD700)

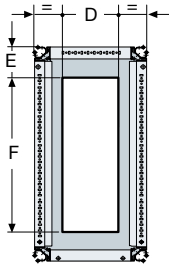

SK4060 (W390xD500)
SK4080 (W390xD700)

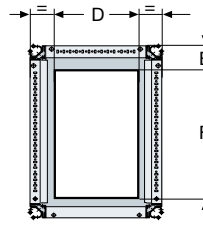

SK6060 (W600xD500)
SK6080 (W600xD700)

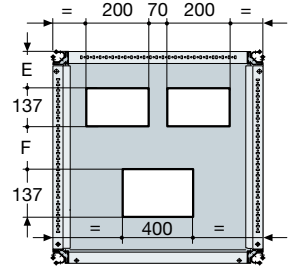

SK8040 (W800xD225)

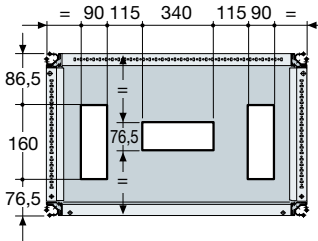

SK8060 (W800xD500)

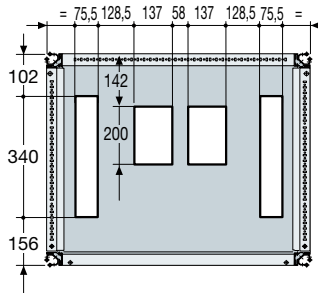

SK8080 (W800xD700)

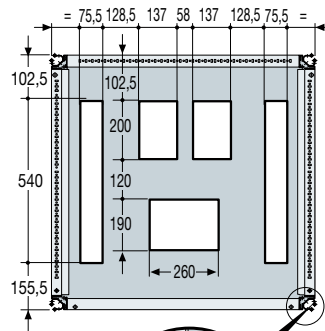

SK4010 (W390xD900)
SK6010 (W600xD900)
SK8010 (W800xD900)
VC3010 (W300xD900)

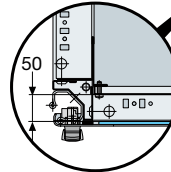
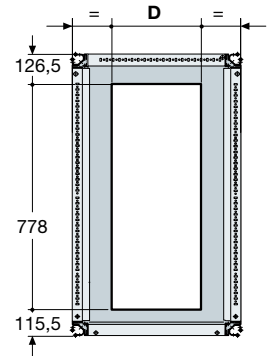

	D	E	F
SK6025 (W600xD150)	320	140	70
SK8025 (W800xD150)	320	140	70
SK4040 (W390xD225)	200	108	137
SK4050 (W390xD300)	320	94,5	235
SK4060 (W390xD500)	320	99	420
SK4080 (W390xD700)	320	99	620
SK4010 (W390xD900)	270	125	780
SK6040 (W600xD225)	540	123,5	70
SK6050 (W600xD300)	530	94,5	235
SK6060 (W600xD500)		93	163
SK6080 (W600xD700)		123	333
SK6010 (W600xD900)	467	125	780
SK8050 (W800xD900)	730	94,5	235
SK8010 (W800xD300)	467	125	780
VC3025 (W300xD150)	180	140	57
VC3040 (W300xD225)	200	103	137
VC3050 (W300xD300)	230	99	235
VC3060 (W300xD500)	230	99	420
VC3080 (W300xD700)	230	99	620
VC3010 (W390xD900)	200		

1STC02034F0901

The measurements are in millimetres

ArTu K

Dimensioni di ingombro

ArTu K

Transparent front doors

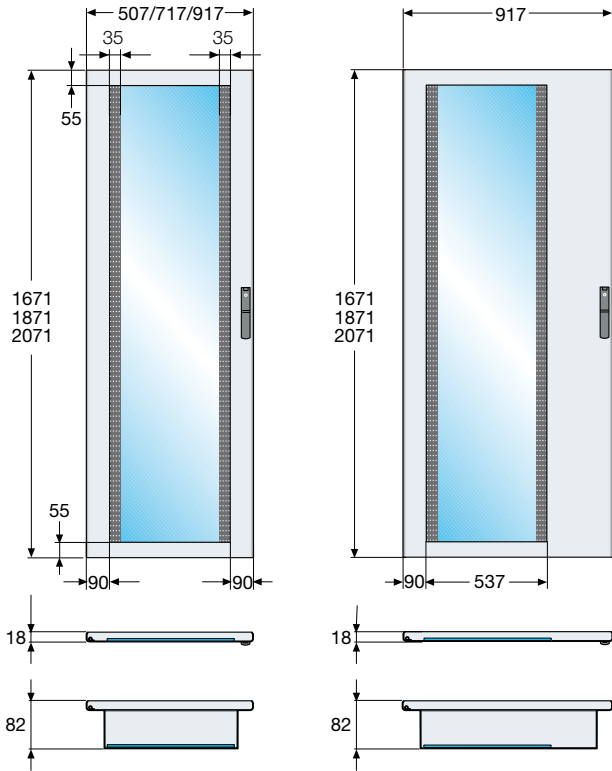

Side door

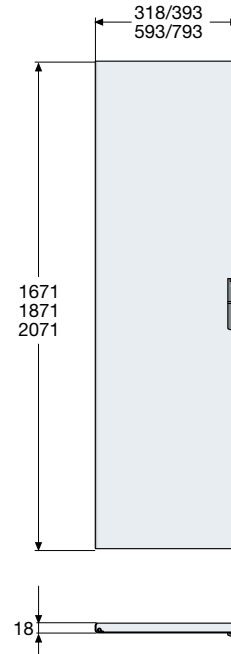

Rear and front blind doors

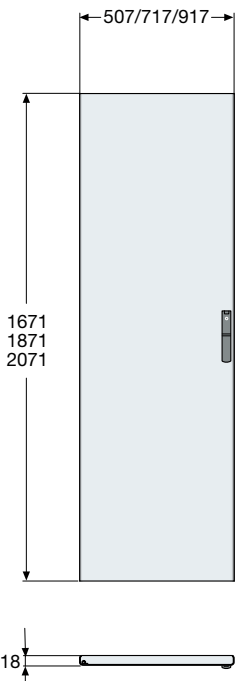

Blind side or ventilated panels

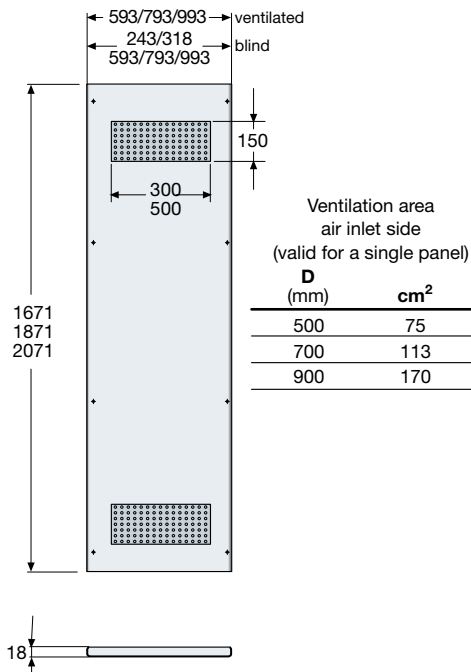

Rear panels

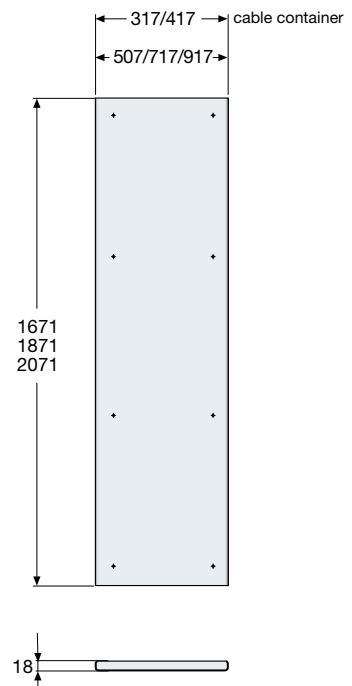

The measurements are in millimetres

ArTu K

Overall dimensions

ArTu K

Fixing to wall/floor

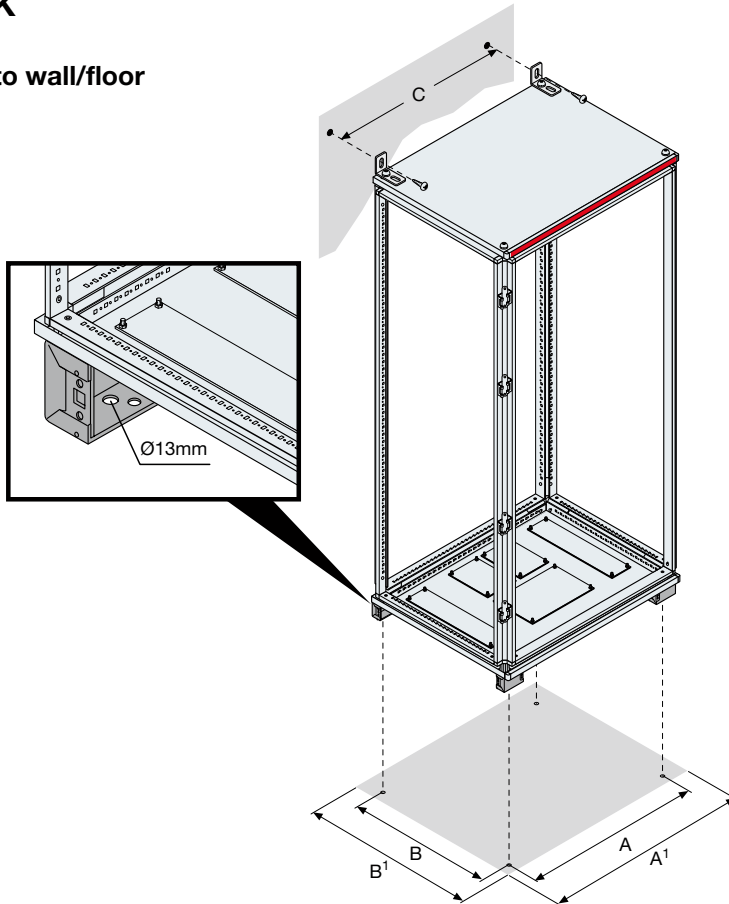

Additional cable container

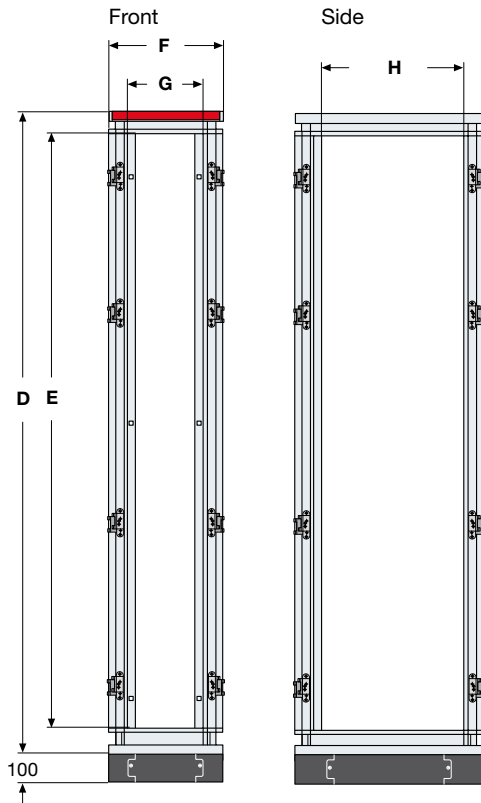

External door (front/rear)

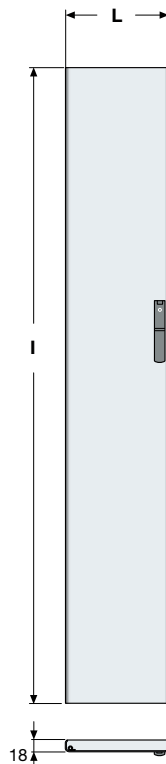

Structure		A	A'	B	B'	C
W600xD150	SK6025	546	720	189	287	620
W800xD150	SK8025	746	920	189	287	820
W390xD225	SK4040	336	510	264	362	410
W390xD300	SK4050	336	510	339	437	410
W390xD500	SK4060	336	510	539	637	410
W390xD700	SK4080	336	510	739	837	410
W390xD900	SK4010	336	510	939	1037	410
W600xD225	SK6040	546	720	264	362	620
W600xD300	SK6050	546	720	339	437	620
W600xD500	SK6060	546	720	539	637	620
W600xD700	SK6080	546	720	739	837	620
W600xD900	SK6010	546	720	939	1037	620
W800xD225	SK8040	746	920	264	362	820
W800xD300	SK8050	746	920	339	437	820
W800xD500	SK8060	746	920	539	637	820
W800xD700	SK8080	746	920	739	837	820
W800xD900	SK8010	746	920	939	1037	820

Additional cable container

		A	A'	B	B'	C
W300xD150	VC3025	246	420	739	287	320
W300xD225	VC3040	246	420	264	362	320
W300xD300	VC3050	246	420	339	437	320
W300xD700	VC3060	246	420	539	637	320
W300xD700	VC3080	246	420	739	837	320
W300xD900	VC3010	246	420	939	1037	320

Reinforced plinth

		A	B
W=420	ZR3000	320	D=287 170
W=510	ZR4000	410	D=362 245
W=720	ZR6000	620	D=437 320
W=920	VC8060	820	D=637 520
			D=837 720
			D=1037 920

height 1600mm

	D	E	F	G	H	I	L
VC3025	1731	1600	420	300	150	1671	417

height 1800mm

	D	E	F	G	H	I	L
VC3025	1931	1800	420	300	150	1871	417
VC3040	1931	1800	420	300	225	1871	417
VC3050	1931	1800	420	300	300	1871	417
VC3060	1931	1800	420	300	500	1871	417
VC3080	1931	1800	420	300	700	1871	417
VC3010	1931	1800	420	300	900	1871	417

height 2000mm

	D	E	F	G	H	I	L
VC3025	2131	2000	420	300	150	2071	417
VC3040	2131	2000	420	300	225	2071	417
VC3050	2131	2000	420	300	300	2071	417
VC3060	2131	2000	420	300	500	2071	417
VC3080	2131	2000	420	300	700	2071	417
VC3010	2131	2000	420	300	900	2071	417

The measurements are in millimetres

ArTu K

Overall dimensions

ArTu K Useful space inside the switchgear

Depth 150mm

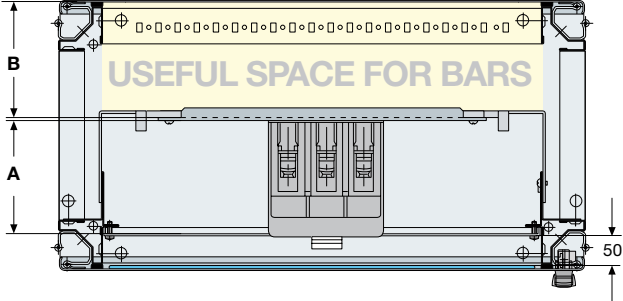

	FIXED		PLUG-IN		WITHDRAWABLE	
	A	B	A	B	A	B
T1-T2-T3	78	146	-	-	-	-
T4-T5-T6	107	117	-	-	-	-
XT1-XT3	74	150	-	-	-	-
XT2-XT4	86	138	-	-	-	-

Depth 225/300mm

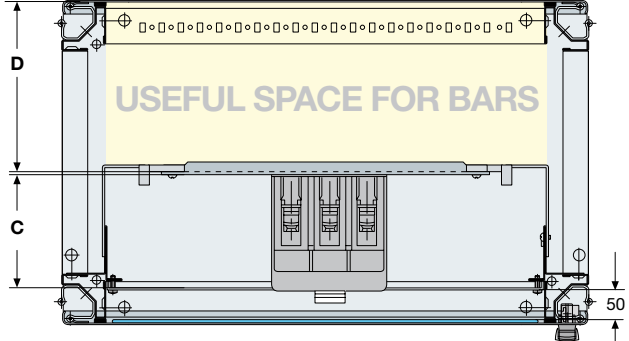

Depth 225	FIXED		PLUG-IN		WITHDRAWABLE	
	C	D	C	D	C	D
T1-T2-T3	78	221	-	-	-	-
T4-T5-T6	107	192	156	144	190	109
XT1-XT3	74	225	-	-	-	-
XT2-XT4	86	213	-	-	-	-
Depth 300						
T1-T2	78	296	-	-	-	-
T4-T5-T6	107	267	156	219	190	184
XT1-XT3	74	300	-	-	-	-
XT2-XT4	86	288	-	-	-	-

Depth 500mm

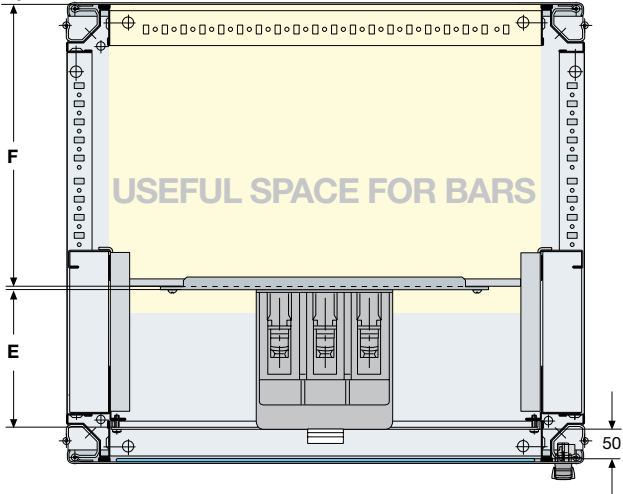

	FIXED		PLUG-IN		WITHDRAWABLE	
	E	F	E	F	E	F
T1-T2-T3	78	456	149	386	-	-
T4-T5-T6	107	467	156	419	190	384
T7-X1	146	-	-	-	241	340
XT1-XT3	74	500	-	-	-	-
XT2-XT4	86	488	-	-	-	-

Depth 700/900mm

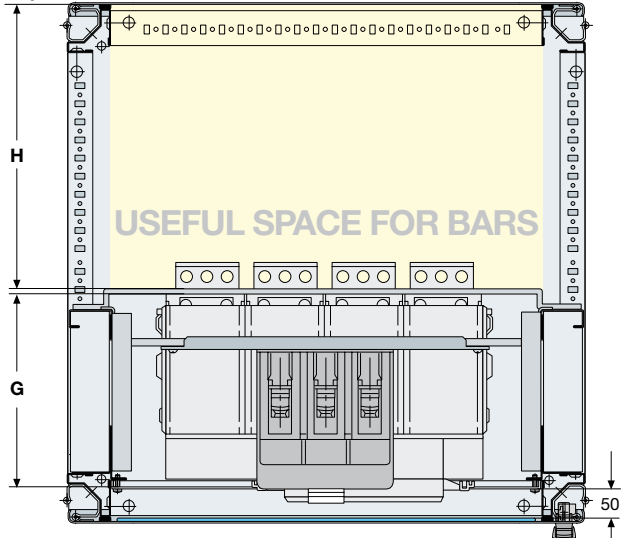

Depth 700	FIXED		PLUG-IN		WITHDRAWABLE	
	G	H	G	H	G	H
T1-T2-T3	78	696	149	626	-	-
T4-T5-T6	107	667	156	619	190	584
T7-X1	146	628	-	-	241	540
E1-E2-E3-E4	236	538	-	-	378	403
XT1-XT3	74	700	-	-	-	-
XT2-XT4	86	688	-	-	-	-
Depth 900						
T1-T2	78	896	-	-	-	-
T4-T5-S6	107	867	156	819	190	784
T7-X1	146	828	-	-	241	740
E1-E2-E3-E4	236	738	-	-	378	603
XT1-XT3	74	900	-	-	-	-
XT2-XT4	86	888	-	-	-	-

The measurements are in millimetres

ArTu L - M - K

Kit for apparatus

ArTu L - M - K - Panels for apparatus mounted on DIN rail

1 DIN row

W=390mm (12 DIN mod.)
W=600mm (24 DIN mod.)
W=800mm (36 DIN mod.)

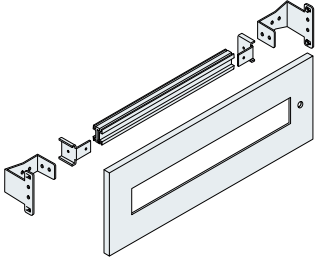

2 DIN rows

W=600mm (48 DIN mod.)
W=800mm (72 DIN mod.)

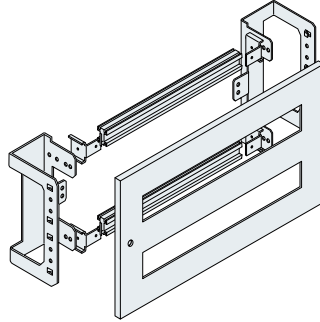

3 DIN rows

W=600mm (72 DIN mod.)

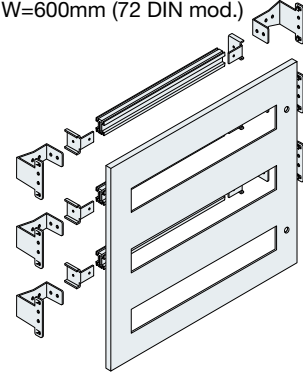

Width 390mm

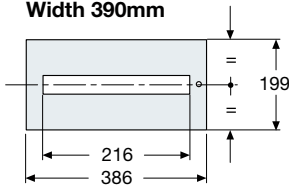

Width 600/800mm

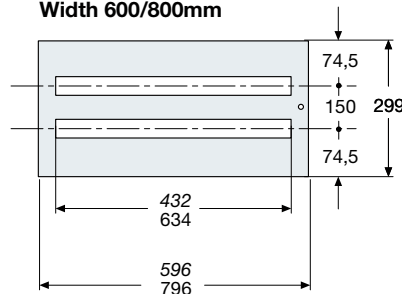

Width 600mm

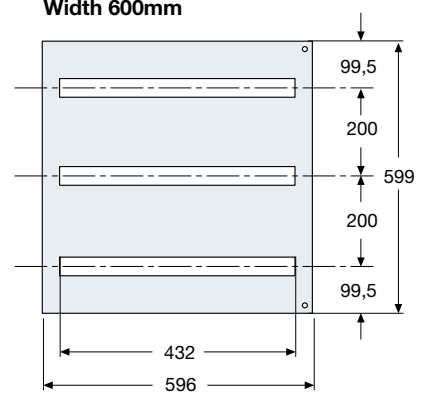

Width 600/800mm

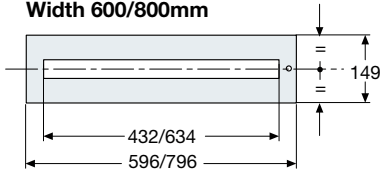

Width 600/800mm

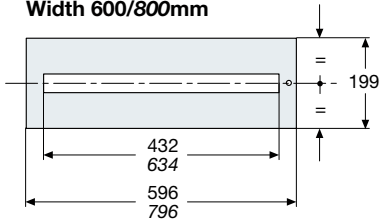

Version for Tmax with diff. mod.

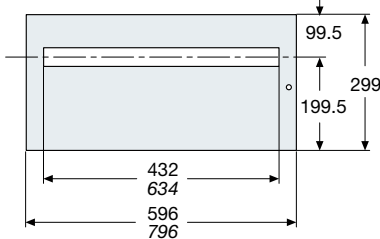

Version for Unifix H

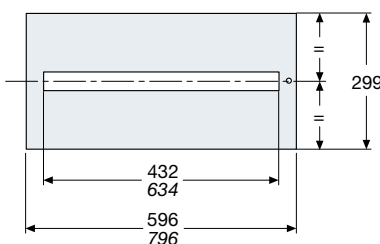

1ST/02/02/BBF0001

The measurements are in millimetres

ArTu L - M - K

Kit for apparatus

ArTu L - M - K - Blind flat and blind recessed plates

Useful dimensions of blind flat plates - PF

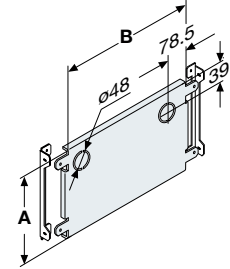
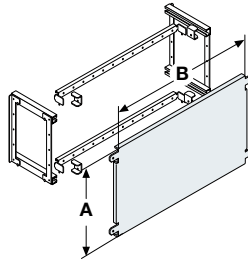
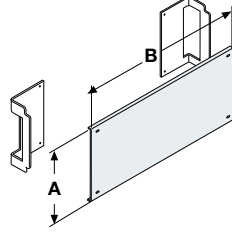
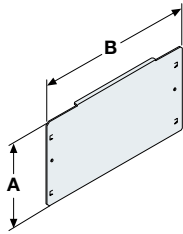

H functional (mm)	ArTu L		ArTu M - K d=150mm		ArTu K without segregation		ArTu K segregated													
	W=600mm	W=800mm	W=600mm	W=800mm	W=390mm	W=600mm	W=800mm	W=390mm	W=600mm	W=800mm	W=390mm	W=600mm	W=800mm							
	A	B	A	B	A	B	A	B	A	B	A	B	A	B						
200	175	440	175	592	184	449	184	649	184	284	184	440	184	640	190	374	190	584	190	784
300	275	440	275	592	-	-	-	-	284	224	284	450	284	650	290	374	290	584	290	784
400	375	440	375	592	384	449	384	649	384	284	384	440	384	640	390	374	390	584	390	784
600	575	440	575	592	-	-	-	-	584	284	584	470	584	650	590	374	590	584	590	784
800	775	440	775	592	-	-	-	-	-	-	-	-	-	-	-	-	790	584	790	784

Useful dimensions of blind recessed plates - FR

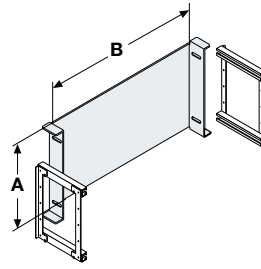
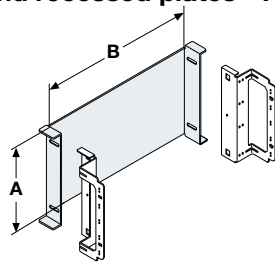

H functional (mm)	ArTu L		ArTu M - K d=150mm		ArTu K without segregation		ArTu K segregated									
	W=600mm	W=800mm	W=600mm	W=800mm	W=390mm	W=600mm	W=800mm	W=390mm	W=600mm	W=800mm						
	A	B	A	B	A	B	A	B	A	B						
200	-	-	191	426	191	626	-	-	180	526	180	726	-	-	-	-
400	-	-	391	426	391	626	-	-	257	526	257	726	-	-	-	-
600	-	-	-	-	-	-	-	-	400	526	400	726	-	-	-	-

ArTu K - Adjustable back plate

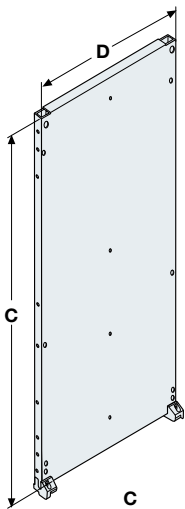

	C	D
PF1806	1776	580
PF1808	1776	780
PF2006	1966	580
PF2008	1966	780

ArTu L - M - K - Blind and ventilated panels

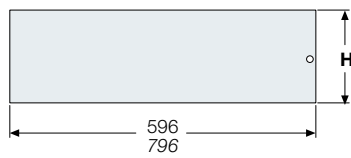

Blind	Ventilated
H	H
99	99
199	199
299	
399	
499	
599	
799	

ArTu L - M - K - Panels for instruments

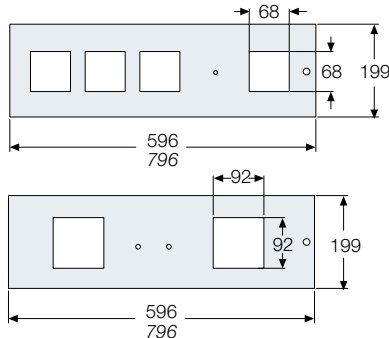

ArTu L - M - K Blind and recessed panels

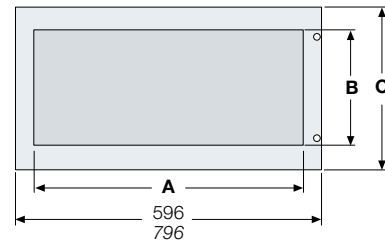
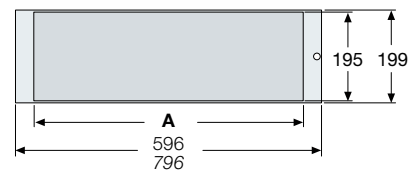

Code	A	B	C
PR2600	506		
PR2800	706		
PR4600	506	308	399
PR4800	706	308	399
PR6600	506	508	599
PR6800	706	508	599

The measurements are in millimetres

ArTu L - M - K

Distribution systems

ArTu L - M - K - Busbar with shaped section

Busbars

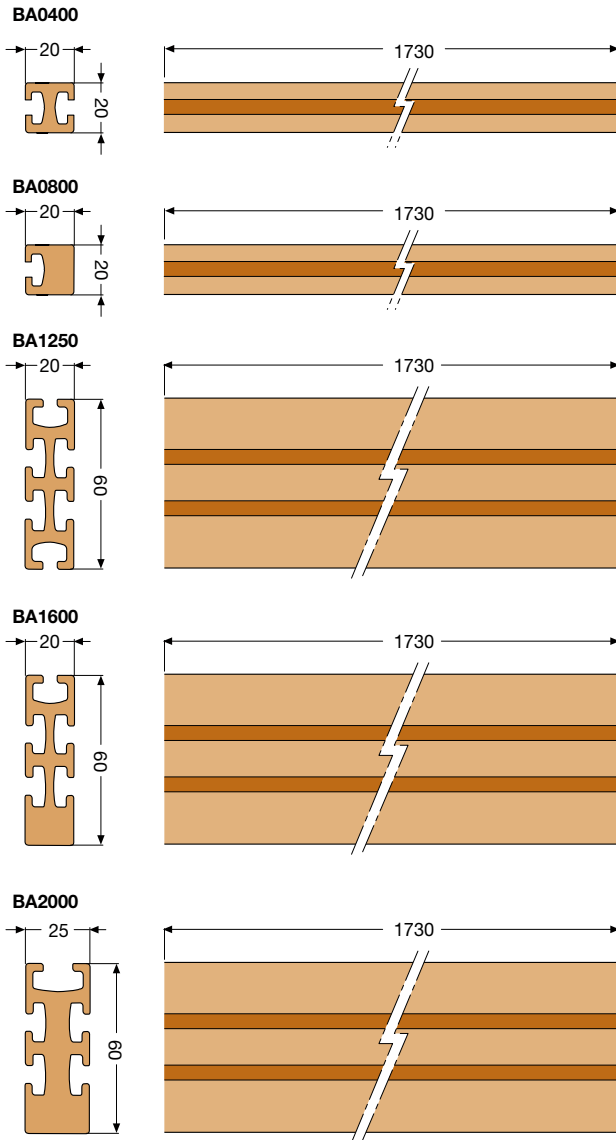

Accessories

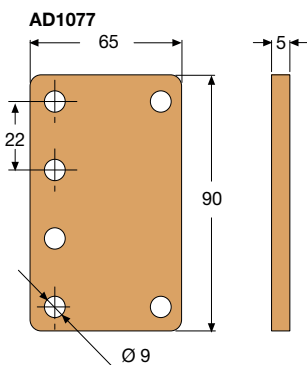

Insulators

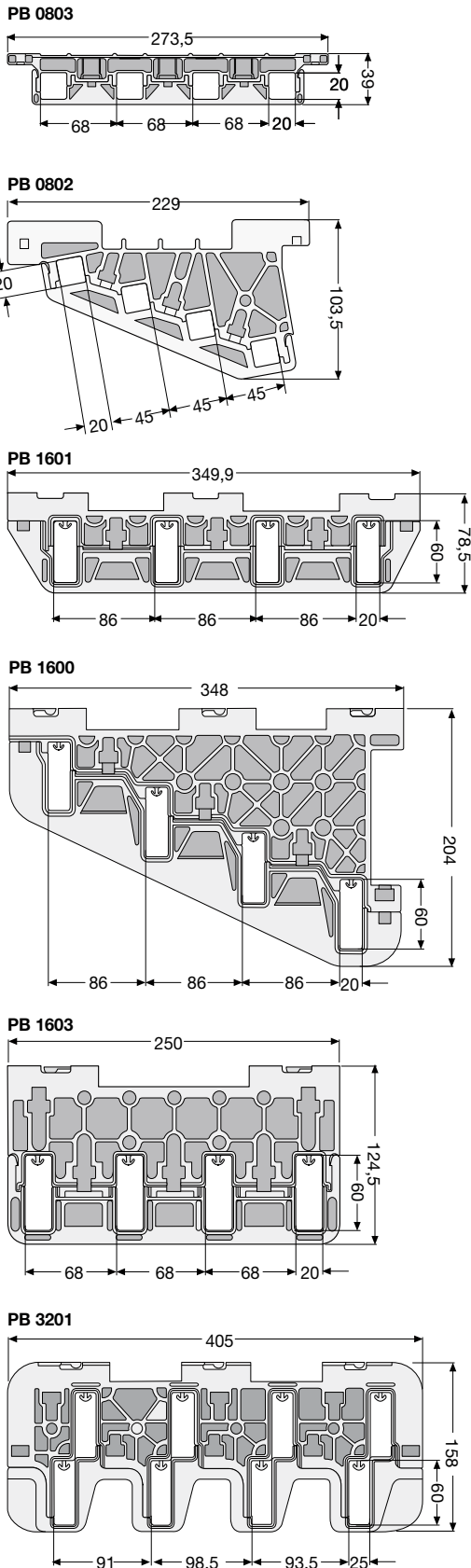

The measurements are in millimetres

1STC0620208F0901

ArTu L - M - K

Distribution systems

ArTu L - M - K - Flat busbars

Busbars up to 630A

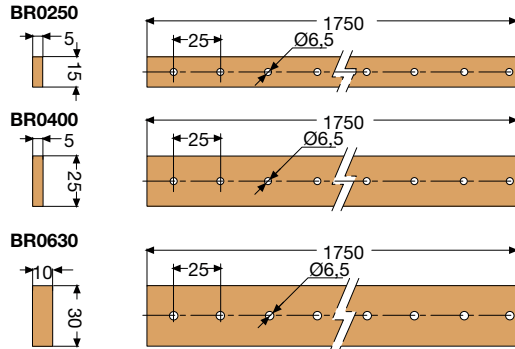

Busbars up to 4000A

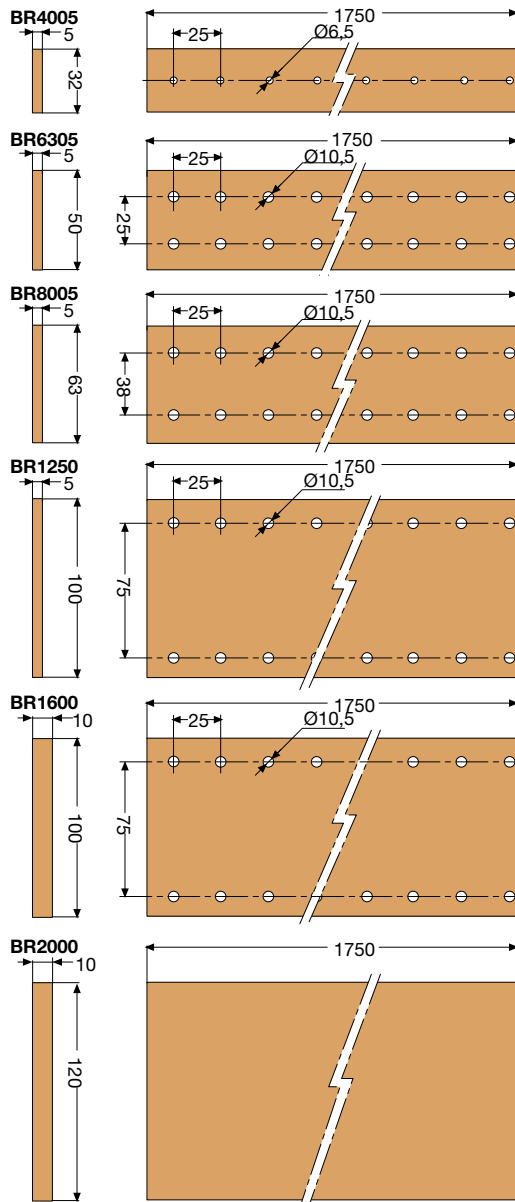

Insulators for busbars up to 630A

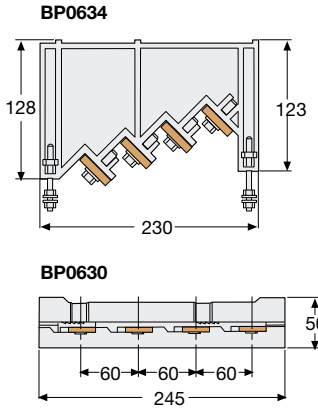

Insulators for busbars up to 4000A

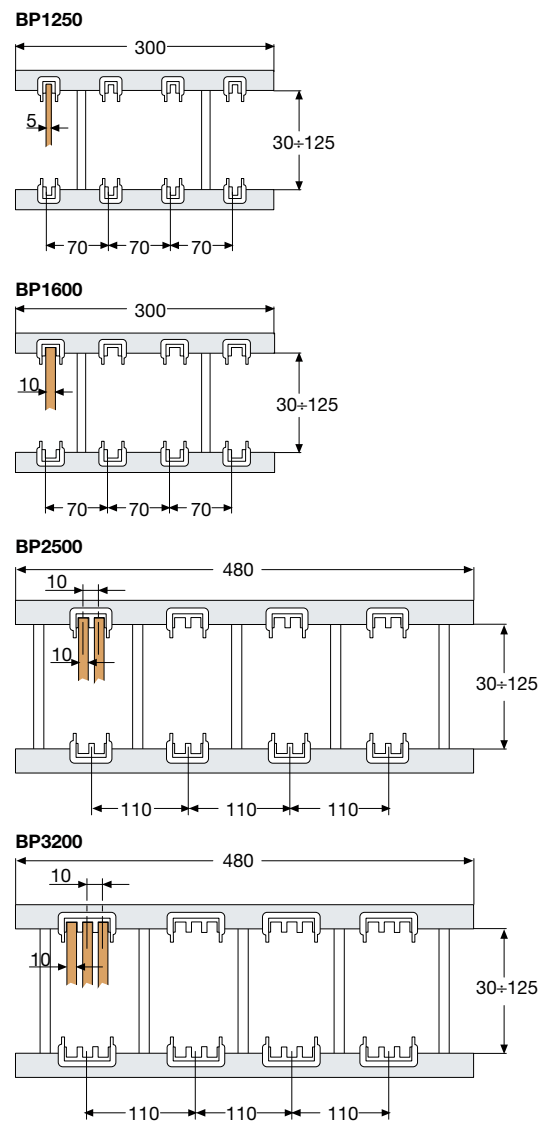

The measurements are in millimetres

ArTu L - M - K

Distribution systems

Unifix cabling system

Unifix H

Front view

24 - 36 modules

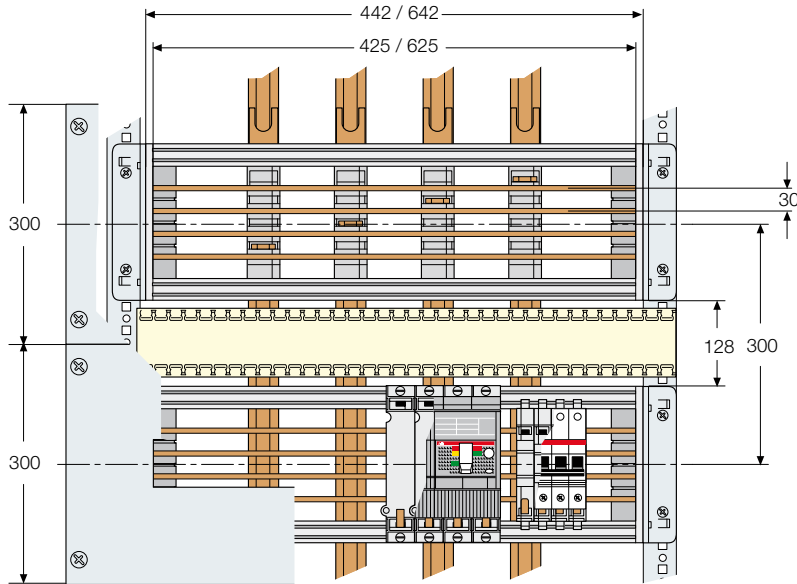

Side view

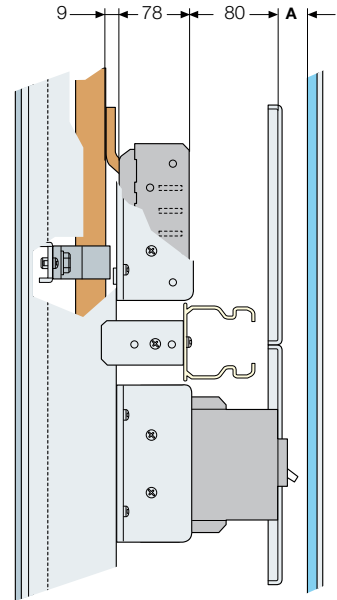

Unifix L

Front view

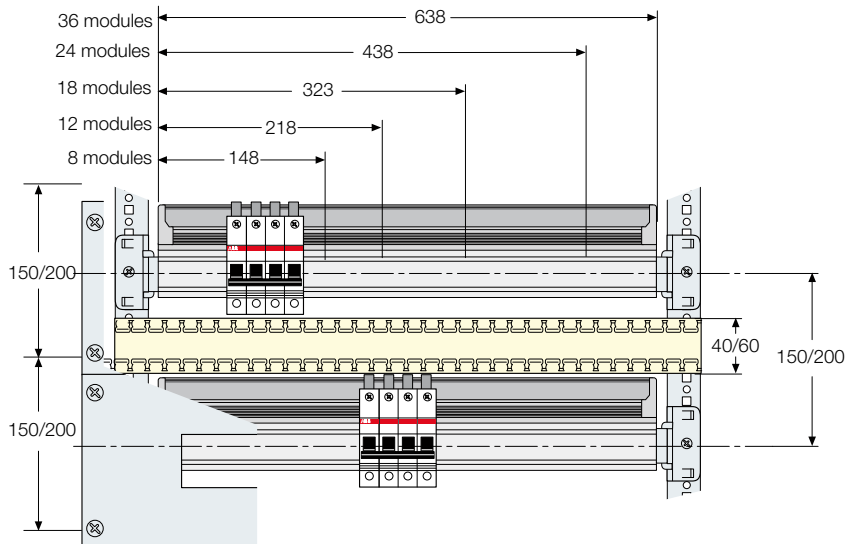

Side view

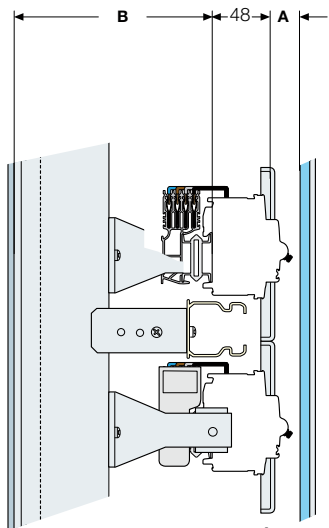

	A	B
ArTu L Wall-mounted	29	104
ArTu L Floor mounted	29	140
ArTu M Wall-mounted (D=150)	21	73
ArTu M Wall-mounted (D=200)	21	123
ArTu M Floor mounted	40	152
ArTu K (D=150)	50	173
ArTu K (D=225)	50	248
ArTu K (D=300)	50	323
ArTu K (D=500)	50	523
ArTu K (D=700)	50	723
ArTu K (D=900)	50	923

The measurements are in millimetres

ArTu L - M - K

Distribution systems

Accessories

Aluminium section EV1050

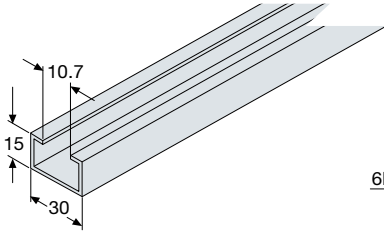

Aluminium nuts for EV1050

EV1056

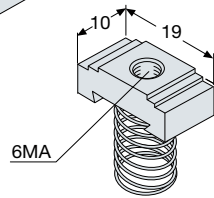

EV1058

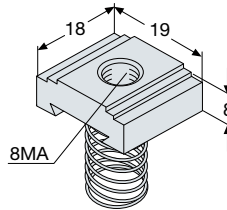

Angles for busbars EV105

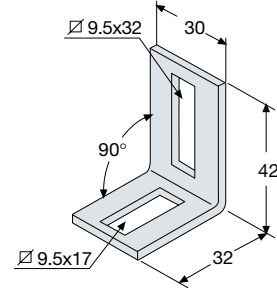

Brackets for cables EV1090 / EV1091

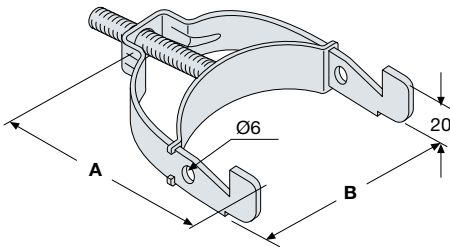

	A	B
EV1090	49	20
EV1091	65	36
EV1092	85	51
EV1093	106	80

Terminal box supports

EV1110

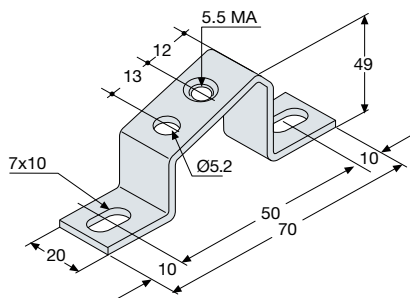

Depth adapter

AP6000

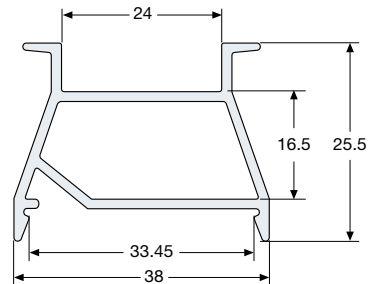

EV1112

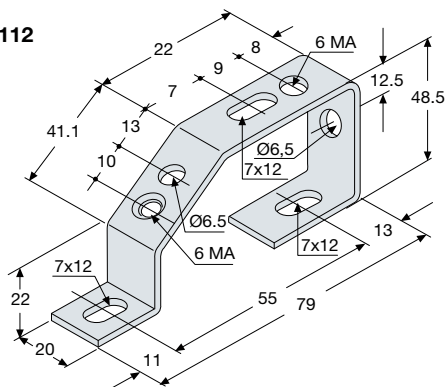

AP6000

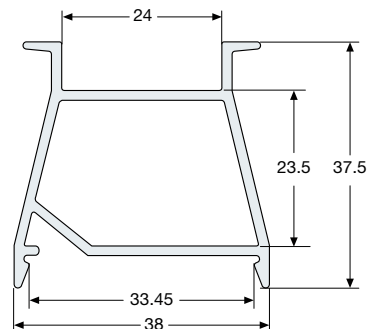

The measurements are in millimetres



Index

Gemini switchboards

Structure.....	9/2
Completion of structure.....	9/4
Accessories	9/9

ArTu L modular structures

Structure	9/12
Kit for apparatus	9/18
Distribution system	9/22
Accessories	9/28

ArTu M monobloc structures

Structure	9/32
Kit for apparatus	9/36
Distribution system	9/40
Accessories	9/46

ArTu K modular structures

Structure (without segregation/segregated switchgear)	9/51
Kit for apparatus (without segregation/segregated switchgear)	9/57
Kit for reduced frame apparatus (without segregation switchgear d=150-225-300mm).....	9/60
Kit for standard frame apparatus (without segregation switchgear d=225mm).....	9/61
Kit for apparatus (segregated switchgear)	9/64
Segregation	9/67
Distribution system.....	9/68
Accessories	9/78

ArTu L - M - K

Kit which can be managed at time of offer	9/83
---	------

List of codes	9/89
----------------------------	------

Gemini switchboards

Structure

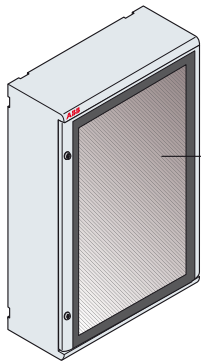
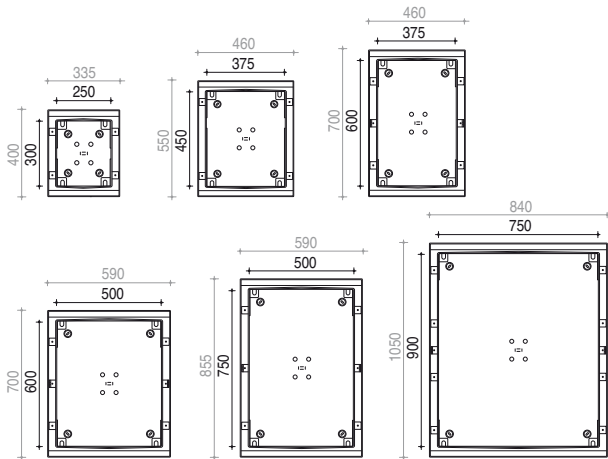

1SL0211A00
1SL0212A00
1SL0213A00
1SL0214A00
1SL0215A00
1SL0216A00

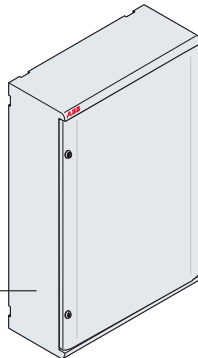

1SL0201A00
1SL0202A00
1SL0203A00
1SL0204A00
1SL0205A00
1SL0206A00

Boxes and doors

- Available in 6 sizes
- Single order code combined with box and transparent and opaque door
- Pack with door dismantled and wrapped separately
- Door designed so that it can be hooked onto hinges at both vertical sides and mounted without the use of tools
- To be mounted to the wall using internal holes or fixing brackets supplied as accessories
- Door opening at an angle of more than 180°
- RAL 7035 grey color
- Doors supplied with 2 standard double bit locks (3 for sizes 5 and 6) that can be replaced with locks for ciphered key or with square/triangular impression (the standard triplex key is suitable for use with three types of impressions).

Size	Code	Description	N° vertical mod.	Useful dimensions	
				WxHxD (mm)	Unit./Pack
	Transparent door	Opaque door		H=150mm	
1	1SL0211A00 1SL0201A00	Structure with door	2	250x300x180	1/1
2	1SL0212A00 1SL0202A00	Structure with door	3	375x250x230	1/1
3	1SL0213A00 1SL0203A00	Structure with door	4	375x600x230	1/1
4	1SL0214A00 1SL0204A00	Structure with door	4	500x600x230	1/1
5	1SL0215A00 1SL0205A00	Structure with door	5	500x750x330	1/1
6	1SL0216A00 1SL0206A00	Structure with door	6	750x900x330	1/1

Gemini switchboards

Structure

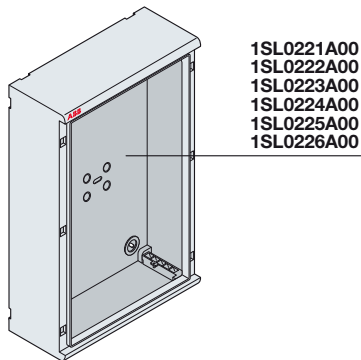

1SL0221A00
1SL0222A00
1SL0223A00
1SL0224A00
1SL0225A00
1SL0226A00

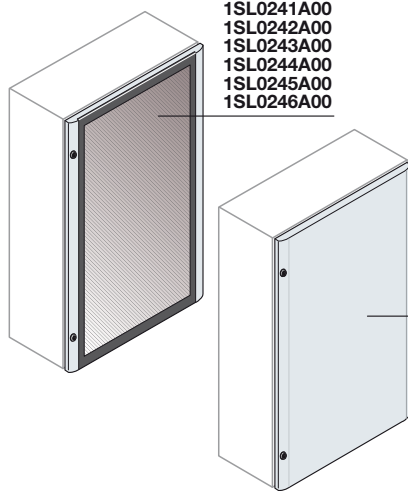

1SL0241A00
1SL0242A00
1SL0243A00
1SL0244A00
1SL0245A00
1SL0246A00

1SL0231A00
1SL0232A00
1SL0233A00
1SL0234A00
1SL0235A00
1SL0236A00

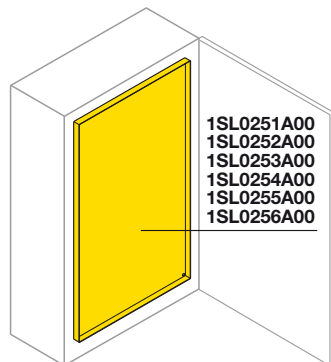

1SL0251A00
1SL0252A00
1SL0253A00
1SL0254A00
1SL0255A00
1SL0256A00

Single box

Size	Code	Description	N° vertical mod. H=150mm	Useful dimensions WxHxD (mm)	Unit./Pack
1	1SL0221A00	Box without door	2	250x300x180	1/1
2	1SL0222A00	Box without door	3	375x250x230	1/1
3	1SL0223A00	Box without door	4	375x600x230	1/1
4	1SL0224A00	Box without door	4	500x600x230	1/1
5	1SL0225A00	Box without door	5	500x750x330	1/1
6	1SL0226A00	Box without door	6	750x900x330	1/1

Single doors

Size	Code		Description	Box dimensions WxHxD (mm)	Unit./Pack
	Transparent door	Opaque door			
1	1SL0241A00	1SL0231A00	Frontal door	250x300x180	1/1
2	1SL0242A00	1SL0232A00	Frontal door	375x250x230	1/1
3	1SL0243A00	1SL0233A00	Frontal door	375x600x230	1/1
4	1SL0244A00	1SL0234A00	Frontal door	500x600x230	1/1
5	1SL0245A00	1SL0235A00	Frontal door	500x750x330	1/1
6	1SL0246A00	1SL0236A00	Frontal door	750x900x330	1/1

Inner doors

- Made in insulating material
- IP40 degree of protection with door open
- Designed so that door can be hinged onto both vertical sides
- Snap-on mounting and fixing

Size	Code	Description	Useful dimensions WxHxD (mm)	Unit./Pack
1	1SL0251A00	Internal inner door	250x300x180	1/4
2	1SL0252A00	Internal inner door	375x250x230	1/4
3	1SL0253A00	Internal inner door	375x600x230	1/2
4	1SL0254A00	Internal inner door	500x600x230	1/2
5	1SL0255A00	Internal inner door	500x750x330	1/2
6	1SL0256A00	Internal inner door	750x900x330	1/1

Fixing kit

- For fixing inner doors with screws

Code	Description	Unit./Pack
1SL0400A00	Kit for fixing inner doors with screws	1/2

Gemini switchboards

Completion of structure

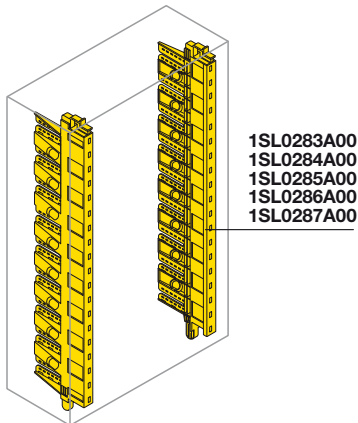

Uprights

- Incorporated vertical wiring duct (ABB patent)
- Snap-on mounting of all components (installation pitch of 75 mm)
- Snap-on insertion into box
- Depth of installed components adjusted at a pitch of 12.5 mm (4 positions for uprights of size 1 and 6 positions for the remaining ones)
- Ergonomic grip to make it easy to insert and extract

Size	Code	Description	Useful dimensions	
			H (mm)	Unit./Pack
1	1SL0283A00	Upright with integrated wiring duct	300	1/4
2	1SL0284A00	Upright with integrated wiring duct	450	1/4
3/4	1SL0285A00	Upright with integrated wiring duct	600	1/4
5	1SL0286A00	Upright with integrated wiring duct	750	1/2
6	1SL0287A00	Upright with integrated wiring duct	900	1/1

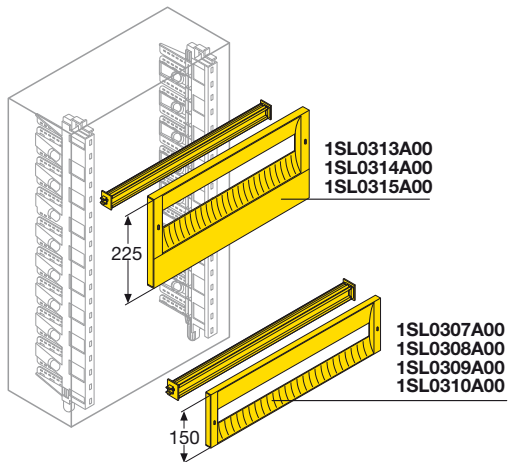

DIN rail kit

- Supplied with DIN rail complete with supports to snap onto uprights and adjustable in depth
- Available in 1 module (H 150 mm) and 1+1/2 module (H 225 mm, sizes 2-6) dimensions
- Designed to be hinged onto both vertical sides
- Snap-on mounting onto uprights (in compliance with reference Standards a tool must be used for removing the panel)
- Document pocket for storing descriptions of installed devices

Size	Code	Description	N° horiz. mod.	Dimensions W (mm)	Unit./Pack
			1 module	1+1/2 modules	
1	1SL0307A00	Panel + DIN rail	12	250	1/8
2/3	1SL0308A00 1SL0313A00	Panel + DIN rail	18	375	1/8
4/5	1SL0309A00 1SL0314A00	Panel + DIN rail	24	500	1/4
6	1SL0310A00 1SL0315A00	Panel + DIN rail	36	700	1/2

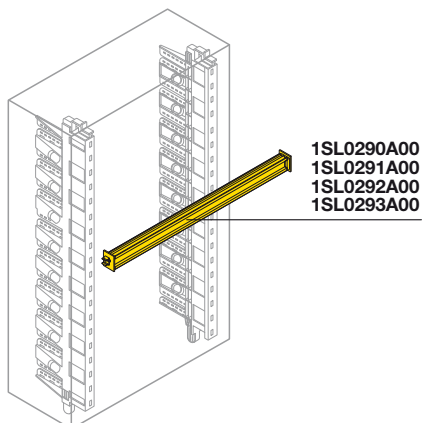

DIN rail

- Two-sided version
- Supplied with mounting supports that snap onto uprights
- Depth adjustment on uprights
- Designed so that rapid Unifix L mounting bars can be snapped on

Size	Code	Description	N° horiz. mod.	Dimensions W (mm)	Unit./Pack
1	1SL0290A00	DIN rail	12	250	1/10
2/3	1SL0291A00	DIN rail	18	375	1/10
4/5	1SL0292A00	DIN rail	24	500	1/10
6	1SL0293A00	DIN rail	36	700	1/10

Gemini switchboards

Completion of structure

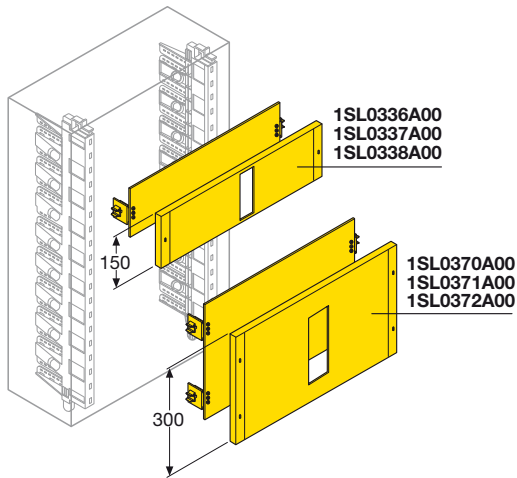

Kit for installing Tmax moulded-case circuit breakers

- For installing Tmax moulded-case circuit breakers in fixed version with front terminals
- Composed of a plate with special drilled holes and a protection panel with vertical slots that can be hinged on both sides and snap-on mounted (in compliance with reference Standards a tool must be used for removing the panel)
- Available for sizes 2-6
- Version H 150 with drillings for Tmax T1 3 poles (with and without residual current releaser), Tmax T1 4 poles (with and without residual current releaser), Tmax T2 3 poles (with and without residual current releaser), Tmax T2 4 poles (without residual current releaser)
- Version H 300 with drillings for Tmax T2 4 poles (with residual current releaser), Tmax T3 3 poles (with and without residual current releaser), Tmax T3 4 poles (with and without residual current releaser)
- Snap-on mounting onto uprights with the possibility of adjusting the plate depth

Size	Code	Description	Dimensions		
			W (mm)	Unit./Pack	
	1 module H=150mm	2 modules H=300mm			
2/3	1SL0336A00	1SL0370A00	Plate + panel	375	1/4
4/5	1SL0337A00	1SL0371A00	Plate + panel	500	1/4
6	1SL0338A00	1SL0372A00	Plate + panel	700	1/2

When choosing the correct kit, see table on page 2/4.

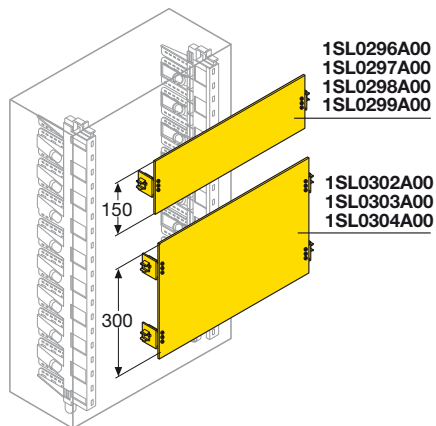

Partial modular plates

- Available in 1 module (H 150 mm) and 2 module (H 300 mm), sizes 2-6) dimensions
- Snap-on mounting onto uprights with depth adjustment

Size	Code	Description	Dimensions	
			W (mm)	Unit./Pack
1 module H=150mm				
1	1SL0296A00	Modular back plate	250	1/6
2/3	1SL0297A00	Modular back plate	375	1/4
4/5	1SL0298A00	Modular back plate	500	1/4
6	1SL0299A00	Modular back plate	700	1/2
2 modules H=300mm				
2/3	1SL0302A00	Modular back plate	318	1/4
4/5	1SL0303A00	Modular back plate	443	1/4
6	1SL0304A00	Modular back plate	663	1/2

Gemini switchboards

Completion of structure

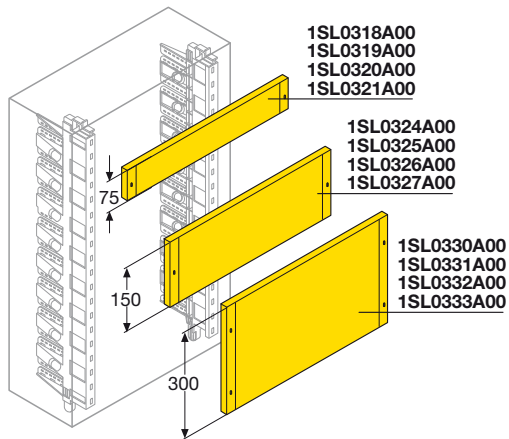

Blank panels

- Available in 1/2 module (H 75 mm), 1 module (H 150 mm) and 2 modules (H 300 mm) dimensions
- H 150 mm and H 300 mm panels designed to be hinged onto both vertical sides
- Snap-on mounting onto uprights (in compliance with reference Standards a tool must be used for removing the panel)

Size	Code	Description	Dimensions	
			W (mm)	Unit./Pack
1/2 module H=75mm				
1	1SL0318A00	Blind front panel	250	1/10
2/3	1SL0319A00	Blind front panel	375	1/10
4/5	1SL0320A00	Blind front panel	500	1/6
6	1SL0321A00	Blind front panel	700	1/4
1 module H=150mm				
1	1SL0324A00	Blind front panel	250	1/8
2/3	1SL0325A00	Blind front panel	375	1/8
4/5	1SL0326A00	Blind front panel	500	1/4
6	1SL0327A00	Blind front panel	700	1/4
2 module H=200mm				
1	1SL0330A00	Blind front panel	250	1/6
2/3	1SL0331A00	Blind front panel	375	1/6
4/5	1SL0332A00	Blind front panel	500	1/4
6	1SL0333A00	Blind front panel	700	1/4

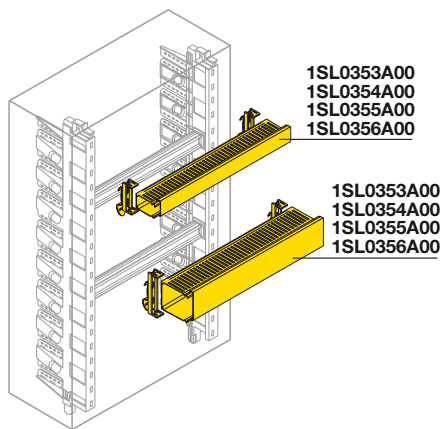

Wiring kit

- Composed of wiring duct in versions 25x60 mm and 40x60 mm (WxH, 8-12 mm slots) and Fix-O-Rapid device for the rapid snap-on hooking of the ducts on the DIN rail
- Snap-on mounting on uprights with depth adjustment

Size	Code	Description	Dimensions		
			W (mm)	Unit./Pack	
		Wiring duct 25x60mm	Wiring duct 40x60mm		
1	1SL0353A00	1SL0360A00	Wiring duct + Fix-O-Rapid	250	1/4
2/3	1SL0354A00	1SL0361A00	Wiring duct + Fix-O-Rapid	375	1/4
4/5	1SL0355A00	1SL0362A00	Wiring duct + Fix-O-Rapid	500	1/4
6	1SL0356A00	1SL0363A00	Wiring duct + Fix-O-Rapid	700	1/4

Gemini switchboards

Completion of structure

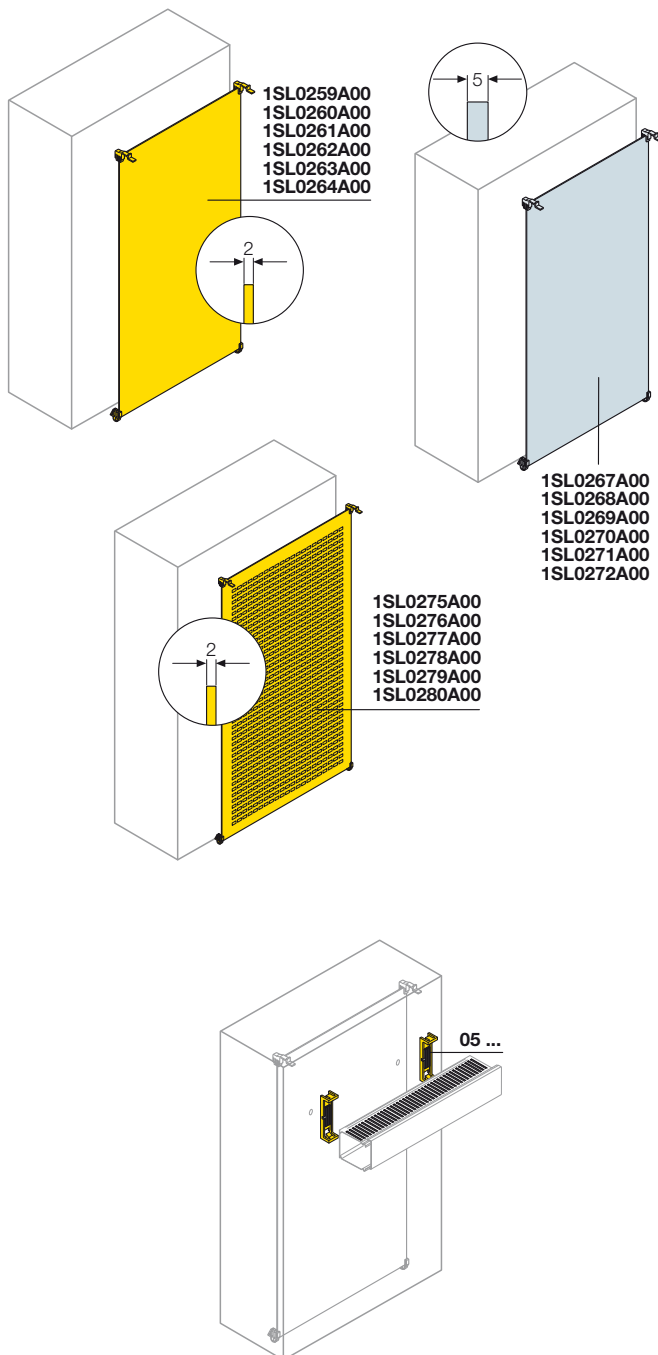

Base plates

- Available in three versions in blank or drilled metal and insulating material
- Positioning at 3 different depths for size 1, 4 different depths for sizes 2-3-4 and 7 different depths for sizes 5-6 (adjustments with 30 mm pitch)
- Supplied with feet and hooks adjustable at three further positions (with 7.5 mm pitch)
- Snap-on mounting
- Plates can also be mounted directly on the base with the special kit

Size	Code			Description	Box dimensions WxHxD (mm)	Unit./Pack
	In blank metal	In drilled metal	Insulating material			
1	1SL0259A00	1SL0275A00	1SL0267A00	Base plate	250x300x180	1/6
2	1SL0260A00	1SL0276A00	1SL0268A00	Base plate	375x250x230	1/6
3	1SL0261A00	1SL0277A00	1SL0269A00	Base plate	375x600x230	1/4
4	1SL0262A00	1SL0278A00	1SL0270A00	Base plate	500x600x230	1/4
5	1SL0263A00	1SL0279A00	1SL0271A00	Base plate	500x750x330	1/4
6	1SL0264A00	1SL0280A00	1SL0272A00	Base plate	750x900x330	1/2

Code	Description	Unit./Pack
1SL0383A00	Base mounting kit for metal plate	1/10

Fix-O-Rapid

Rapid mounting device for attaching wiring ducts to the base plate: it snaps onto the plate after drilling a $\varnothing 7$ mm hole. Two Fix-O-Rapid devices are enough for each wiring duct section. Fix-O-Rapid guarantees maximum insulation since it does not involve the use of any metal component inside the wiring duct. If the wrong wiring duct is selected, it can be dismantled and a version with the same base and a different height can be attached to the Fix-O-Rapid.

Code	Description	Unit./Pack
05 270	Rapid mounting device for wiring duct, W 25mm	20/600
05 272	Rapid mounting device for wiring duct, W 40mm	20/600
05 274	Rapid mounting device for wiring duct, W 60mm	20/600
05 276	Rapid mounting device for wiring duct, W 80mm	20/240
05 278	Rapid mounting device for wiring duct, W 100mm	20/240
05 280	Rapid mounting device for wiring duct, W 125mm	20/240
05 282	Rapid mounting device for wiring duct, W 150mm	20/240

Gemini switchboards

Completion of structure

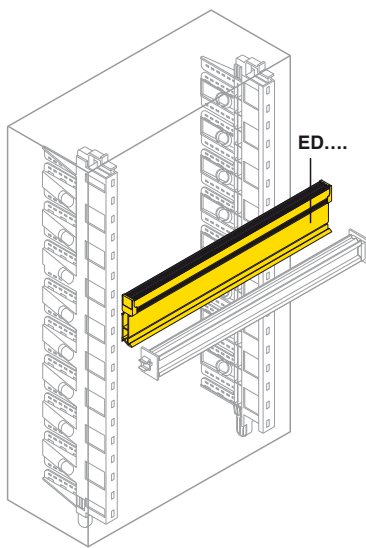

2 poles

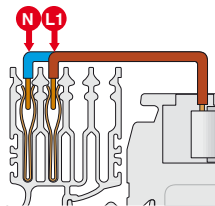

4 poles

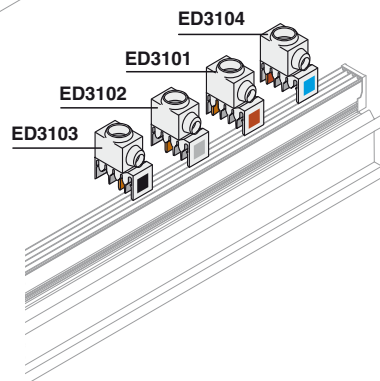
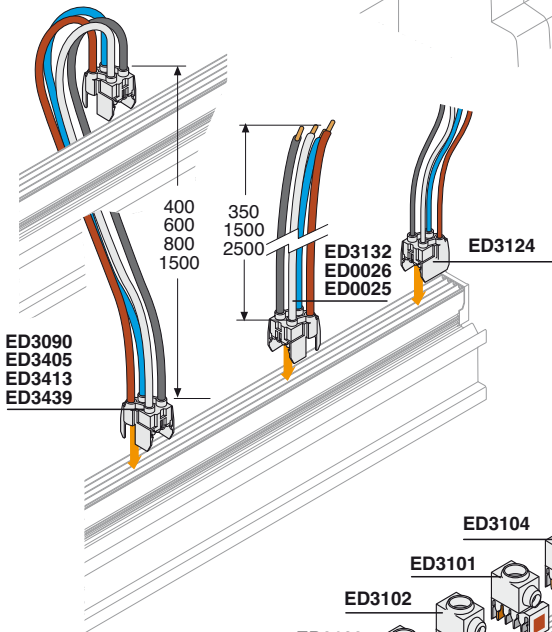
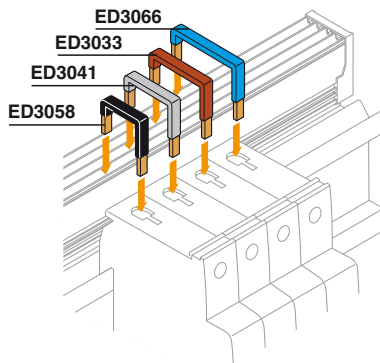
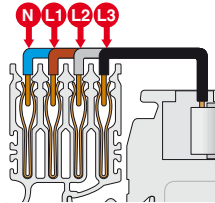

Unifix L

2-poles busbars

Code	Description	Dimensions W (mm)	Unit./Pack
ED2993	100A 2P 12 module busbar	400	1/6
ED3009	100A 2P 18 module busbar	450	1/6
ED3017	100A 2P 24 module busbar	600	1/6
ED3025	100A 2P 36 module busbar	800	1/6

4-poles busbars

Code	Description	Dimensions W (mm)	Unit./Pack
ED2944	100A 4P 12 module busbar	400	1/6
ED2951	100A 4P 18 module busbar	450	1/6
ED2969	100A 4P 24 module busbar	600	1/6
ED2977	100A 4P 36 module busbar	800	1/6

Connections for various apparatus

Code	Description	Unit./Pack
ED3108	Connection with 2 conductors L/N 16A	1/6
ED3116	Connection with 3 conductors L1/L2/L3 16A	1/6
ED3124	Connection with 4 conductors L1/L2/L3/N 16A single phase	1/6
ED3355	Connection with 2 conductors L1/N 40A	1/6
ED3363	Connection with 3 conductors L1/L2/L3 40A	1/6
ED3371	Connection with 4 conductors L1/L2/L3/N 40A	1/6

Connections for apparatus

Code	Description	Unit./Pack
ED3272	N°10 connections L1-N 40 A	1/10
ED3280	N°10 connections L2-N 40 A	1/10
ED3298	N°10 connections L3-N 40 A	1/10
ED3033	N°10 connections L 1 100A	1/10
ED3041	N°10 connections L 2 100A	1/10
ED3058	N°10 connections L 3 100A	1/10
ED3066	N°10 connections N 100A	1/10
ED3132	Feeder with 4P 100A cable (W=350mm)	1/10
ED0026	Feeder with 4P 100A cable (W=1500mm)	1/10
ED0025	Feeder with 4P 100A cable (W=1500mm)	1/10

Power supply modules with cable

Code	Description	Unit./Pack
ED3082	Parallel module 2P 100A with cable	1/6
ED3405	Parallel module 4P 100A with cable	1/6
ED3090	Parallel module 4P 100A with cable	1/6
ED3413	Parallel module 4P 100A with cable	1/6
ED3439	Parallel module 4P 100A with cable	1/6

Power supply modules without cable In 100A

Code	Description	Unit./Pack
ED3101	N°10 single-pole power supply terminals L1	1/10
ED3102	N°10 single-pole power supply terminals L2	1/10
ED3103	N°10 single-pole power supply terminals L3	1/10
ED3104	N°10 single-pole power supply terminals N	1/10

Gemini switchboards

Accessories

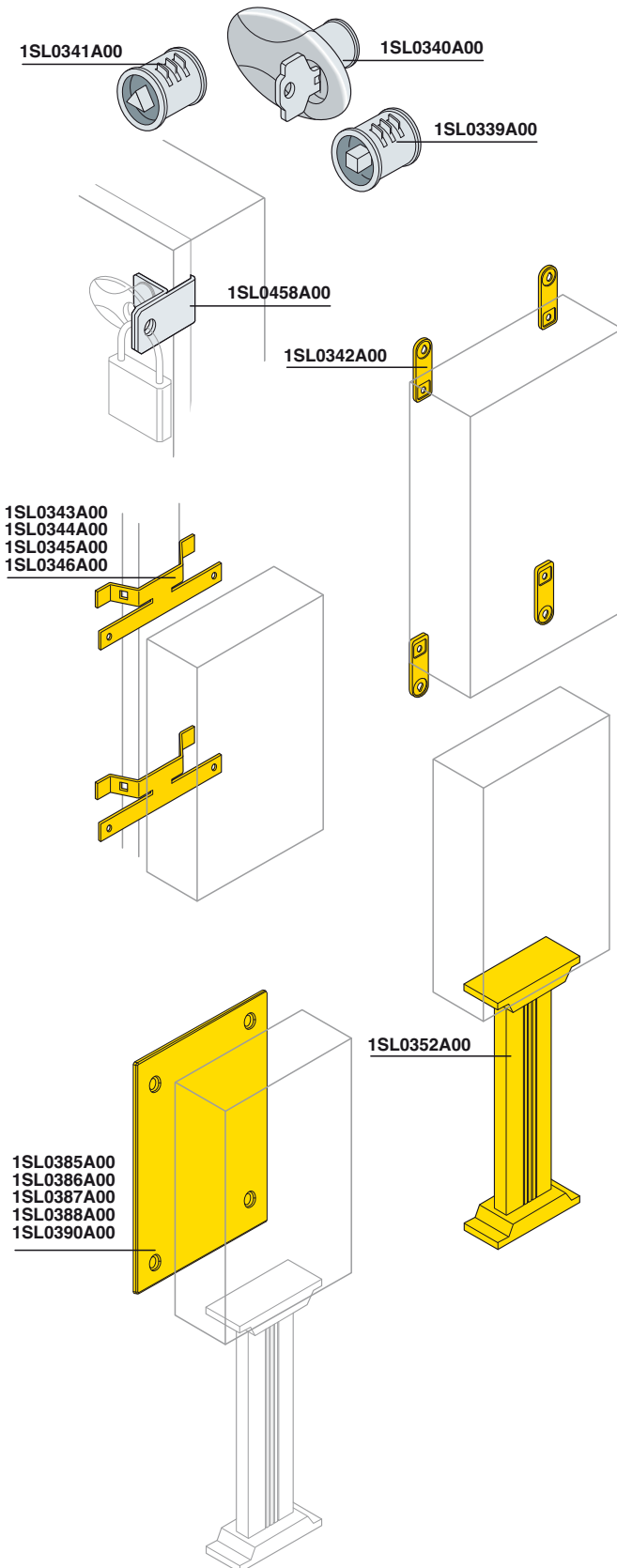

Locks

Available in three versions with ciphered key and handle, with triangular and square impressions

Code	Description	Unit/Pack
1SL0340A00	Lock with Yale type ciphered key and handle	1/10
1SL0341A00	Lock with triangular impression	1/10
1SL0339A00	Lock with square impression	1/10
1SL0458A00	Kit for vandalproof closure	1/10

Mounting elements

Guarantee optimum wall, pole and floor mounting conditions.

Code	Description	Unit/Pack
1SL0342A00	(4) horizontal and vertical wall brackets ⁽¹⁾	1/10
1SL0343A00	Pole mounting kit for sizes 1 switchboards	1/4
1SL0344A00	Pole mounting kit for sizes 2-3 switchboards	1/4
1SL0345A00	Pole mounting kit for sizes 4-5 switchboards	1/2
1SL0346A00	Pole mounting kit for size 6 switchboards	1/2
1SL0352A00	Floor mounting pedestal for sizes 1-4	1/1

⁽¹⁾ There are two types of inserts for adapting brackets to $\varnothing 6$ e 8 mm fixing devices.

Base cover

For aesthetic as well as functional purposes, in particular for pedestal installations.

Size	Code	Description	Unit/Pack
1	1SL0385A00	Back plugging plate	1/4
2	1SL0386A00	Back plugging plate	1/4
3	1SL0387A00	Back plugging plate	1/2
4	1SL0388A00	Back plugging plate	1/2
6	1SL0390A00	Back plugging plate	1/2

Gemini switchboards

Accessories

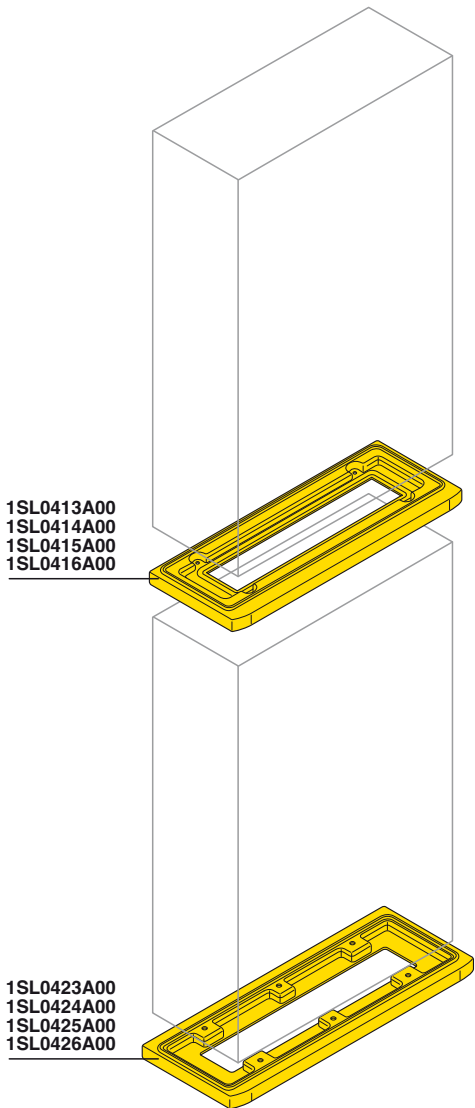

Coupling kit

It follows the aesthetic outline of the boxes. Upon request, contact ABB for minimum order quantities.

Size	Code	Description	Unit./Pack
2/3	1SL0413A00	Vertical coupling kit for sizes	1/2
4	1SL0414A00	Vertical coupling kit for sizes	1/2
5	1SL0415A00	Vertical coupling kit for sizes	1/2
6	1SL0416A00	Vertical coupling kit for sizes	1/2

Bottom base H 30

For fixing the Gemini switchboard directly to the floor. Upon request, contact ABB for minimum order quantities.

Size	Code	Description	Unit./Pack
3	1SL0423A00	Bottom base	1/2
4	1SL0424A00	Bottom base	1/2
5	1SL0425A00	Bottom base	1/2
6	1SL0426A00	Bottom base	1/2

Fixed frame

In combination with bottom base H 30. For fixing onto poured concrete floors and bases. Upon request, contact ABB for minimum order quantities.

Size	Code	Description	Unit./Pack
3	1SL0433A00	Frame for fixing to floor	1/2
4	1SL0434A00	Frame for fixing to floor	1/2
5	1SL0435A00	Frame for fixing to floor	1/2
6	1SL0436A00	Frame for fixing to floor	1/2

Gemini switchboards

Accessories

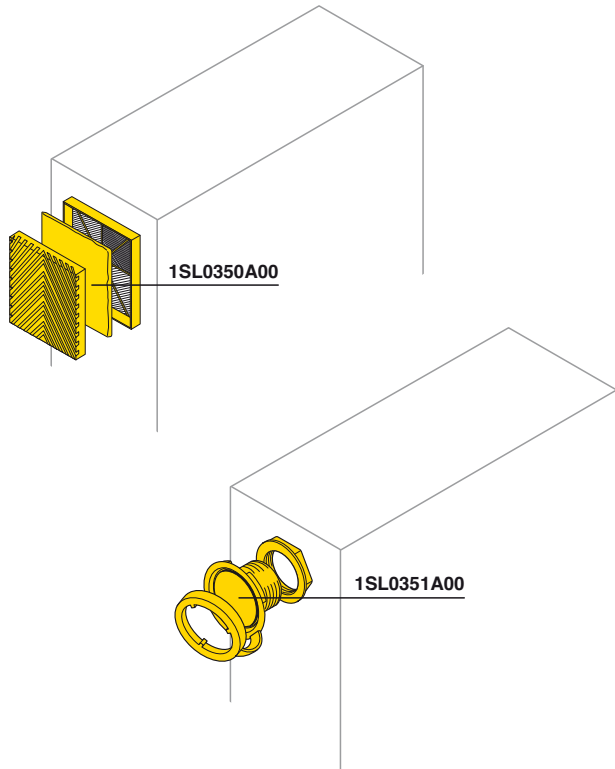

Ventilation kit

- Composed of plastic grills and filter to ensure switchboard ventilation
- IP42
- The filter must be cleaned periodically

Code	Description	Unit./Pack
1SL0350A00	Ventilation kit	1/1

Anti-condensation kit

- Kit in special material to prevent condensation from forming inside the switchboard: it include **GORE™ MEMBRANE VENTING**
- Impermeable to water (pressure): 1,5 bar
- Air flow: 68/h (dp = 70 mbar)
- 1 kit for sizes 1-2, 2 kits for sizes 3-4 and 3 kits for sizes 5-6 are recommended to guarantee adequate dissipation; in any case the number of kits to be installed depend on the number and type of devices installed inside the switchboard.

Code	Description	Unit./Pack
1SL0351A00	Anti-condensation kit	1/6

Other accessories

Code	Description	Unit./Pack
12 849	Universal drill bit	1/30
12 863	Module covers in RAL 7035 grey, 4 modules	25/300
12 851	Deep adapters	10/80
1SL0380A00	Small bag for base plates	1/10
1SL0381A00	Small bag for DIN supports	1/10
1SL0382A00	Small bag for partial plate supports	1/10
1SL0379A00	Small bag with screws and inserts	1/10
1SL0457A00	Spare key	1/10

ArTu L Structure

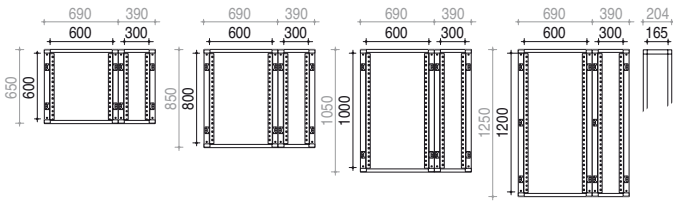

Wall-mounted switchgear

Wall-mounted switchgear structure

Code	Description	Useful dimension HxD (mm)
24 mod DIN W=600mm		
SL0600	Back, roof and base for structure	600x165
SL0800	Back, roof and base for structure	800x165
SL1000	Back, roof and base for structure	1000x165
SL1200	Back, roof and base for structure	1200x165

Additional wall-mounted cable container structure

External cable container

Can be mounted on the right and left of the basic structure, can be used as cable container or as incoming column which can be equipped with kit for Tmax circuit-breakers

Code	Description	Useful dimension WxHxD (mm)
VC0600	Back, roof and base for cable container	300X600x165
VC0800	Back, roof and base for cable container	300X800x165
VC1000	Back, roof and base for cable container	300X1000x165
VC1200	Back, roof and base for cable container	300X1200x165

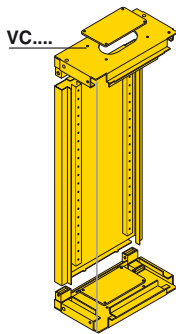
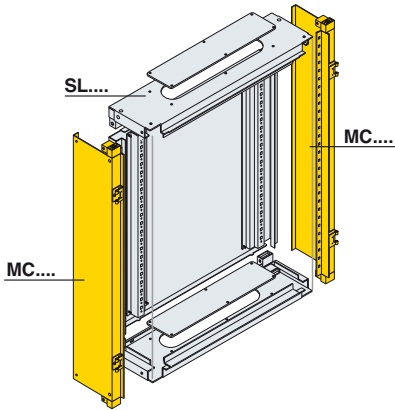

1STC802701F0001

Intermediate uprights for lateral side-by-side positioning or external cable container

Allows several structures side-by-side on the right and left of the basic one.

Code	Description	Dimensions H (mm)
MI0600	Intermediate upright for placing structures side by side	600
MI0800	Intermediate upright for placing structures side by side	800
MI1000	Intermediate upright for placing structures side by side	1000
MI1200	Intermediate upright for placing structures side by side	1200

Side closure with blind panel

Code	Description	Dimensions HXD (mm)
MC0600	N°2 side closures for wall-mounted structures	600x165
MC0800	N°2 side closures for wall-mounted structures	800x165
MC1000	N°2 side closures for wall-mounted structures	1000x165
MC1200	N°2 side closures for wall-mounted structures	1200x165

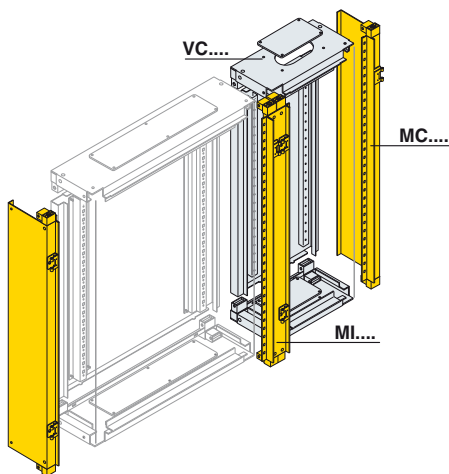

ArTu L Structure

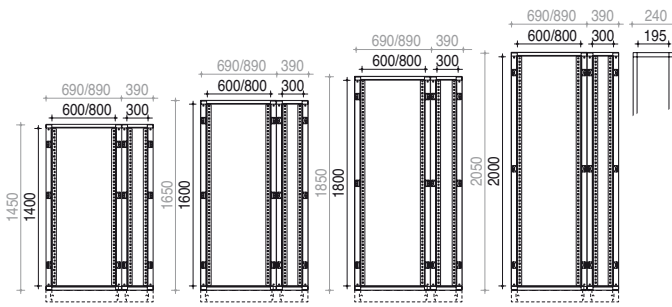

Floor-mounted switchgear

Floor-mounted structure

Code	Description	Useful dimensions HxD (mm)
24 DIN mod 36 DIN mod W=600mm W=800mm		
SL1400	SL1408 Back, roof and base for structure	1400x195
SL1600	SL1608 Back, roof and base for structure	1600x195
SL1800	SL1808 Back, roof and base for structure	1800x195
SL2000	SL2008 Back, roof and base for structure	2000x195

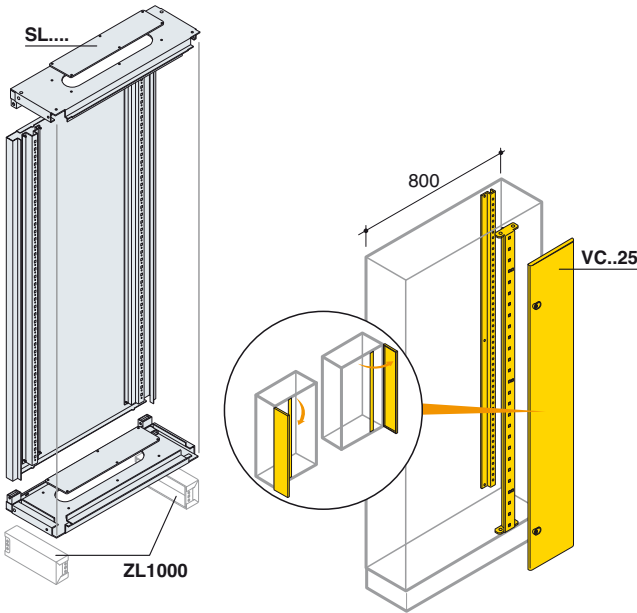

Floor-mounted cable container

Internal cable container structure 36 mod. (W=800mm)

Only to be ordered for the 36 DIN mod. structures (W=800mm).

Consisting of a pair of functional uprights and a blind door complete with two key locks. Can be mounted either on the right or left.

Code	Description	Dimensions WxD (mm)
VC1425	Internal cable container structure SL1408	200x1400x195
VC1625	Internal cable container structure SL1608	200x1600x195
VC1825	Internal cable container structure SL1808	200x1800x195
VC2025	Internal cable container structure SL2008	200x2000x195

External cable container

Can be mounted on the right and left of the basic structure, can be used as cable container or as incoming column which can be equipped with kit for Tmax

Code	Description	Dimensions WxD (mm)
VC1400	Back, roof and base for cable container	300x1400x195
VC1600	Back, roof and base for cable container	300x1600x195
VC1800	Back, roof and base for cable container	300x1800x195
VC2000	Back, roof and base for cable container	300x2000x195

Note: the palletisable base strips (ZL1000 or ZL3000) and the flanges (ZL1001, ZL1101 or ZL2001) must be ordered separately, see page 9/14.

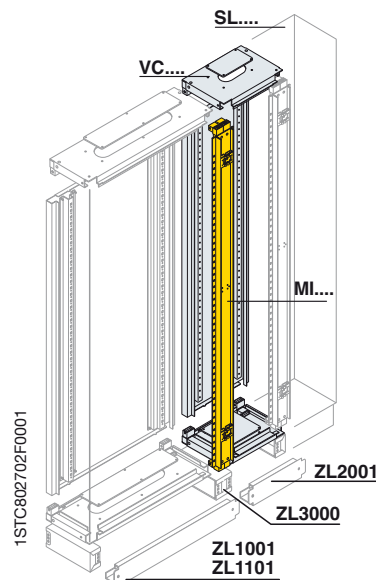

Intermediate uprights for lateral side-by-side positioning or external cable container

Allows several structures side-by-side on the right and left of the basic one.

Code	Description	Dimensions H (mm)
MI1400	Intermediate upright for placing structures side by side	1400
MI1600	Intermediate upright for placing structures side by side	1600
MI1800	Intermediate upright for placing structures side by side	1800
MI2000	Intermediate upright for placing structures side by side	2000

ArTu L Structure

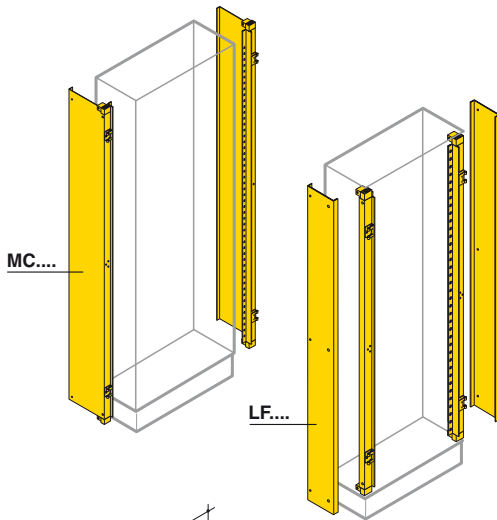

Side closure with blind panel

Code	Description	Dimensions HxD (mm)
MC1400	N°2 side closure for floor-standing structures	1400x195
MC1600	N°2 side closure for floor-standing structures	1600x195
MC1800	N°2 side closure for floor-standing structures	1800x195
MC2000	N°2 side closure for floor-standing structures	2000x195

Side closure with removable panel

Code	Description	Dimensions HxD (mm)
LF1400	N°2 side closures for floor-standing structures	1400x195
LF1600	N°2 side closures for floor-standing structures	1600x195
LF1800	N°2 side closures for floor-standing structures	1800x195
LF2000	N°2 side closures for floor-standing structures	2000x195

Base strips

Angles

Code	Description	Dimensions H (mm)
ZL1000	N°2 angle pieces for structure or cable container	100
ZL3000	Intermediate angle for side-by-side structures	100

Plinth covering flanges

Code	Description	Dimensions H (mm)
24 DIN mod. W=600mm	Ext. cable container W=300mm	100
36 DIN mod. W=800mm		
ZL1001		
ZL1101	N°2 flanges for plinth 100	100

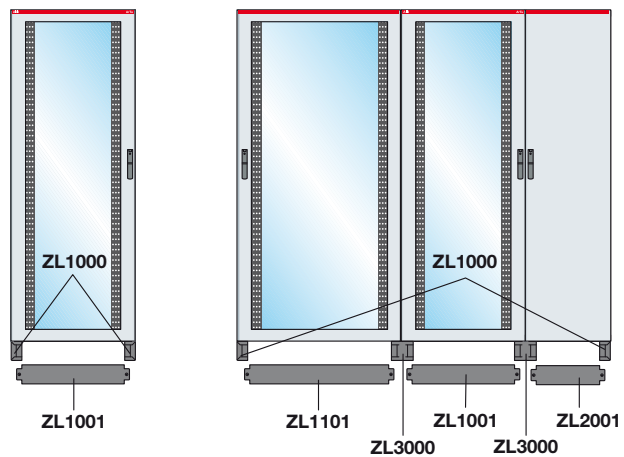
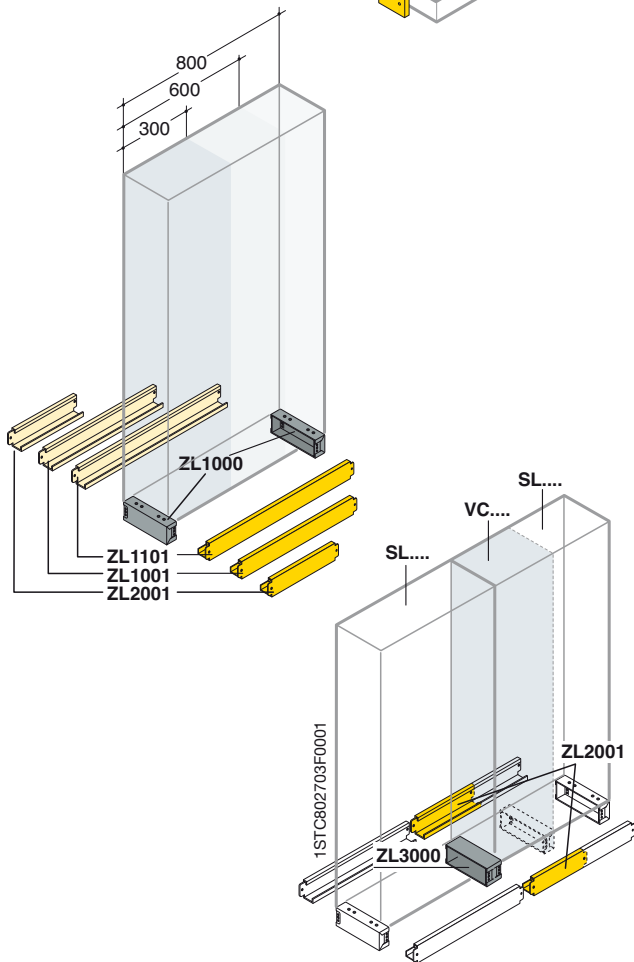

Example of base strip composition for structures

Type of structure	External angle pieces	Side-by-side angle piece	Flanges
W=600mm	ZL1000	ZL3000	ZL1001
W=800mm	ZL1000	ZL3000	ZL1101
W=300mm (external cable container)	ZL1000	ZL3000	ZL2001

ArTu L Structure

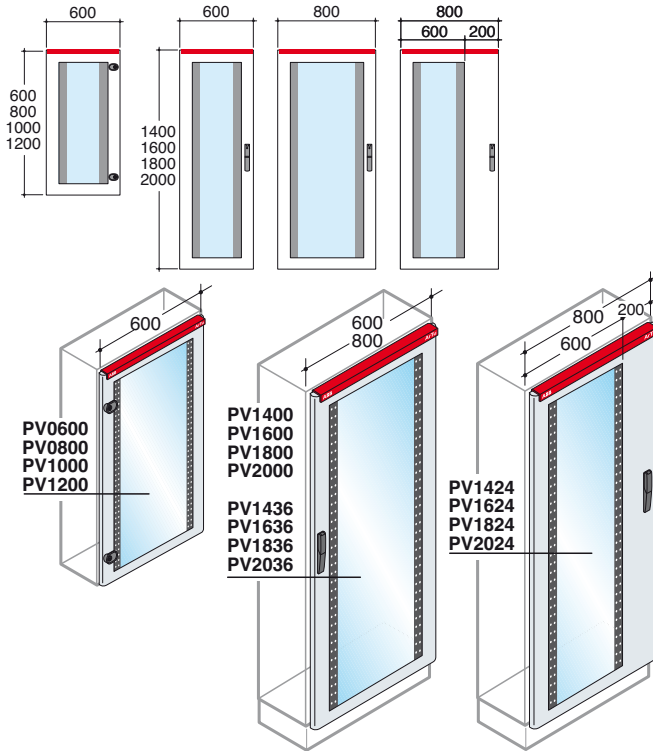

Front IP43 doors for structures

Glass doors 24/36 mod.

Steel sheet door 15/10 thick with 4mm thick safety glass fitted with polyurethane gasket complete with handle with key with double tab.
Reversible, hinged on the right or left.

Code	Description	Dimensions H (mm)		
36 DIN mod+ internal cable cont.				
24 DIN mod W=600mm	36 mod DIN W=800mm			
PV0600	IP43 glass door wall-mounted	600		
PV0800	IP43 glass door wall-mounted	800		
PV1000	IP43 glass door wall-mounted	1000		
PV1200	IP43 glass door wall-mounted	1200		
PV1400	PV1436	PV1424	IP43 glass door floor-standing	1400
PV1600	PV1636	PV1624	IP43 glass door floor-standing	1600
PV1800	PV1836	PV1824	IP43 glass door floor-standing	1800
PV2000	PV2036	PV2024	IP43 glass door floor-standing	2000

IP43 blind doors

Steel sheet door 15/10 thick fitted with polyurethane gasket complete with handle with key with double tab.
Reversible, hinged on the right or left.

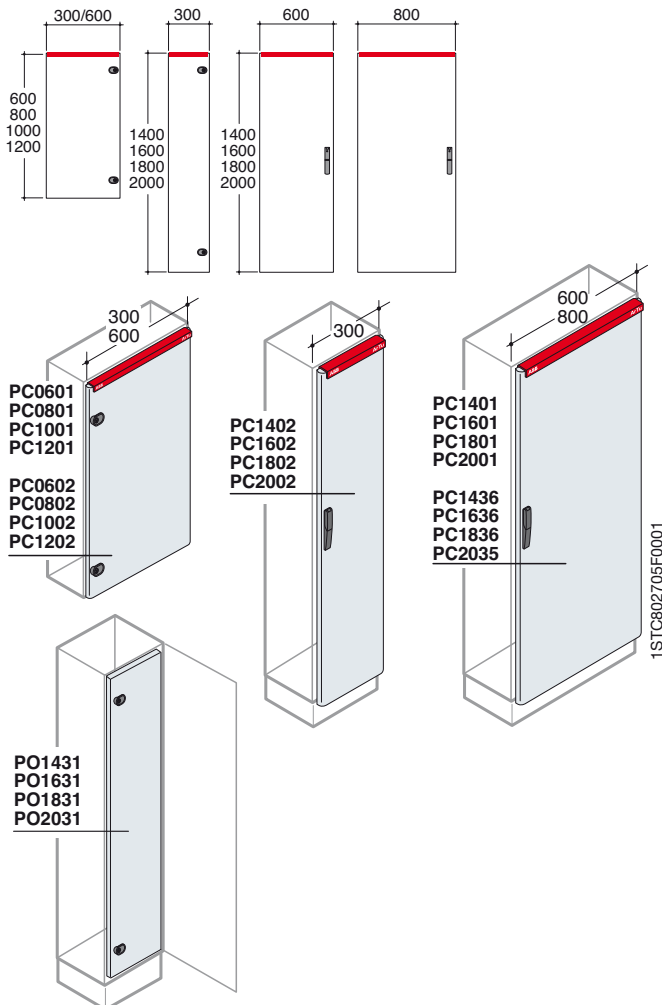

Code	Description	Dimensions H (mm)		
External cable cont.				
24 DIN mod W=600mm	36 mod DIN W=800mm			
PC0601	PC0602	IP43 blind door wall-mounted	600	
PC0801	PC0802	IP43 blind door wall-mounted	800	
PC1001	PC1002	IP43 blind door wall-mounted	1000	
PC1201	PC1202	IP43 blind door wall-mounted	1200	
PC1401	PC1436	PC1402	IP43 blind door floor-standing	1400
PC1601	PC1636	PC1602	IP43 blind door floor-standing	1600
PC1801	PC1836	PC1802	IP43 blind door floor-standing	1800
PC2001	PC2035	PC2002	IP43 blind door floor-standing	2000

Internal door for external cable container

Code	Description	Dimensions H (mm)
PO1431	Internal door for external cable container W=300mm	1400
PO1631	Internal door for external cable container W=300mm	1600
PO1831	Internal door for external cable container W=300mm	1800
PO2031	Internal door for external cable container W=300mm	2000

ArTu L Structure

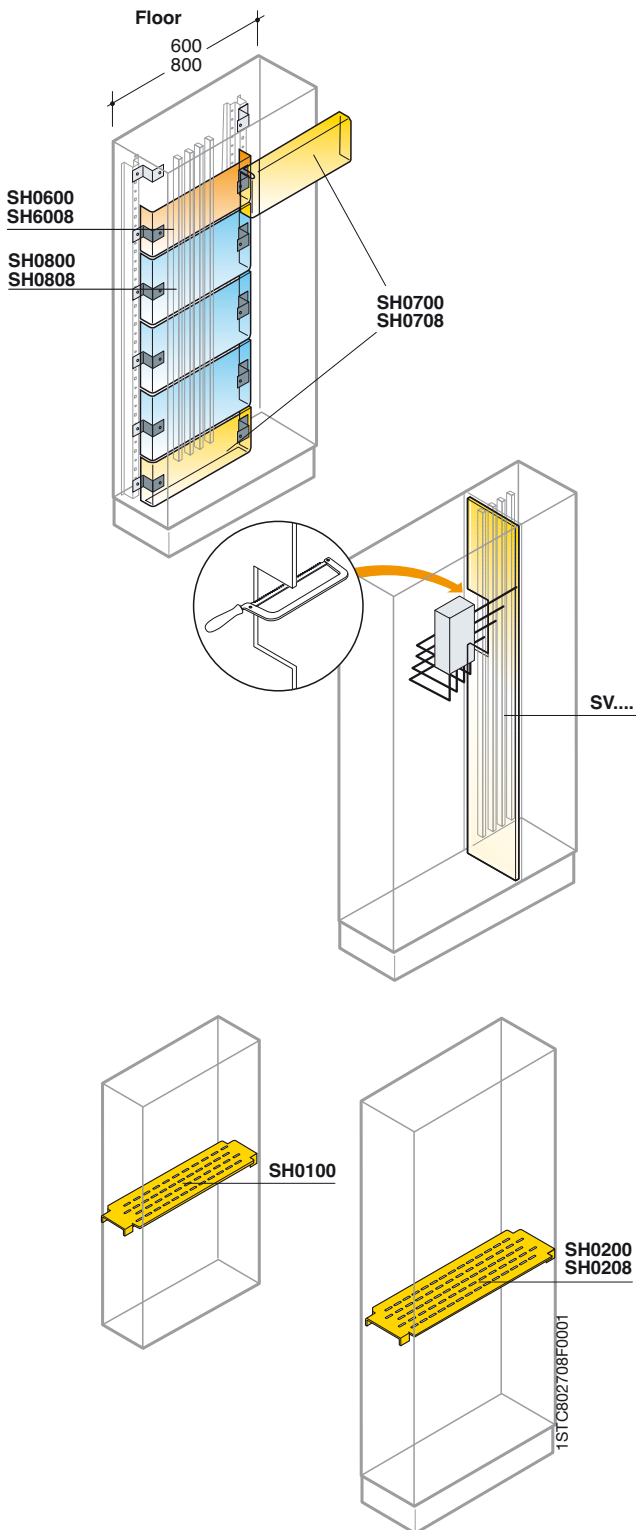

Form 2 segregation (only for structures)

Code	Description	Dimensions H (mm)
24 DIN mod 36 DIN mod		
W=600mm	W=800mm	
SH0600 SH0608	Form 2 segregation kit	200
SH0800 SH0808	Form 2 segregation kit	300
SH0700 SH0708	Form 2 base/head segregation kit	200

Vertical segregations (only for external cable container)

Code	Description	Dimensions HxD (mm)
SV0600	Vertical segregation kit	600x165
SV0800	Vertical segregation kit	800x165
SV1000	Vertical segregation kit	1000x165
SV1200	Vertical segregation kit	1200x165
SV1400	Vertical segregation kit	1400x195
SV1600	Vertical segregation kit	1600x195
SV1800	Vertical segregation kit	1800x195
SV2000	Vertical segregation kit	2000x195

Horizontal shelves

Code	Description
24 DIN mod 36 DIN mod	
W=600mm	W=800mm
SH0100	Horizontal shelf for wall-mounted structure
SH0200 SH0208	Horizontal shelf for floor-mounted structure

ArTu L Structure

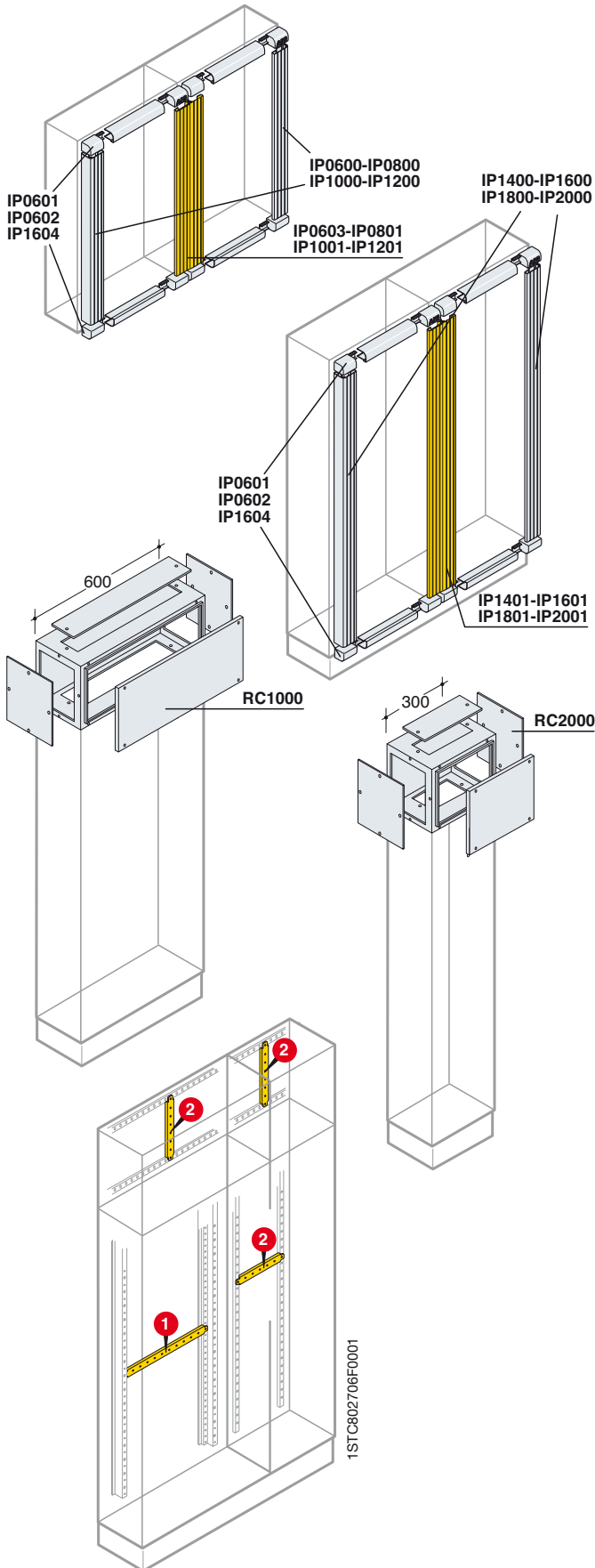

IP31 Finishing profiles

Vertical finishing profile for structure and wall-mounting cable container

Code	Description
Dimensions H (mm)	
600	800
1000	1200
IP0600	IP0800
IP1000	IP1200
N°2 vertical finishing profiles for structure and cable IP31	
IP0603	IP0801
IP1001	IP1201
N°1 vertical finishing profiles for side-by-side IP31	

Vertical finishing profile for structure and floor-mounting cable container

Code	Description
Dimensions H (mm)	
1400	1600
1800	2000
IP1400	IP1600
IP1800	IP2000
N°2 vertical finishing profiles for structure and cable cont. IP31	
IP1401	IP1601
IP1801	IP2001
N°1 vertical finishing profiles for side-by-side structures IP31	

Horizontal finishing profile for structure and cable container

Code	Description
External	
24 DIN mod	36 DIN mod
W=600mm	W=800mm
	W=300mm
IP0601	IP0604
IP0602	
N°2 horizontal finishing profiles	

Connection box

Code	Description	Dimensions HxD (mm)
External		
24 DIN mod.	Ext. cable	
W=600mm	container	
	W=300mm	
RC1000	RC2000	Roof box for floor-mounted structure
		338x195

Crosspieces for accessories

Code	Description	Assembly position
TL1000	N°2 structure rear crosspieces W=600mm	1
TL1100	N°2 structure rear crosspieces W=800mm	1
TL3000	N°2 cable container and box rear crosspieces W=300mm	2
TL2000	N°2 fixing crosspieces W=300mm for scaled busbar holder PBPB0802	2
TL2100	N°2 fixing crosspieces W=200mm for scaled busbar holder PBPB0802	2

Can be mounted on the structure to anchor cables or to mount accessories. They can be mounted on the side, on the rear or in the cable container of the structure.

ArTu L

Kit for apparatus

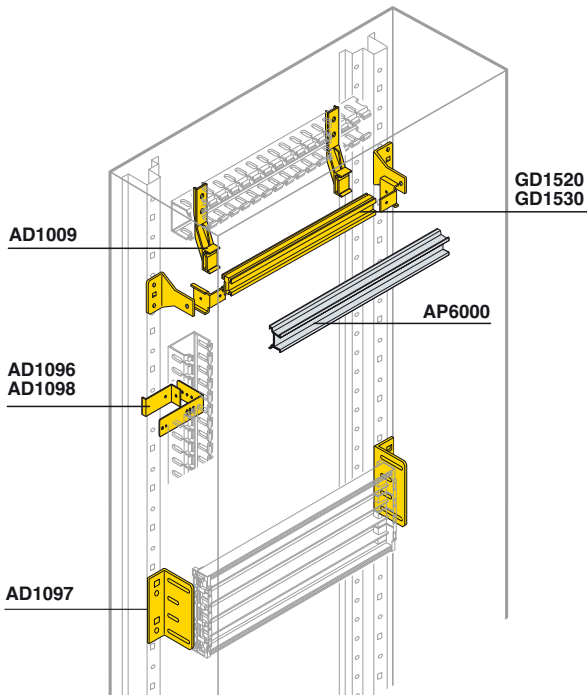

DIN rail kits for System Pro-M modular apparatus, Tmax T1-T2-T3-XT1-XT3, moulded-case circuit-breakers

Kit consisting of double aluminum profile (DIN35) complete with fixing brackets.

Code	Description
12 DIN mod 24 DIN mod 36 DIN mod W=300mm W=600mm W=800mm	
GD1512 GD1520 GD1530	DIN rail kit (aluminium)

Supports for Unifix H

Code	Description
AD1097	for panel H=300mm

Depth adapters

Kit consisting of plastic profile.

Code	Description	Dimensions W (mm)
AP6000	N°1 depth adapter for Tmax T1-T2-T3-XT1-XT3	600

Tmax XT flanges for DIN-rail mounting

Code	Description
AD3301	XT1 3P flange for DIN-rail mounting
AD3302	XT1 4P flange for DIN-rail mounting
AD3303	XT3 3P flange for DIN-rail mounting
AD3304	XT3 4P flange for DIN-rail mounting

already supplied in the DIN-Rail mounting kit for breaker in MCCBs catalogue 1SDC210033D0901

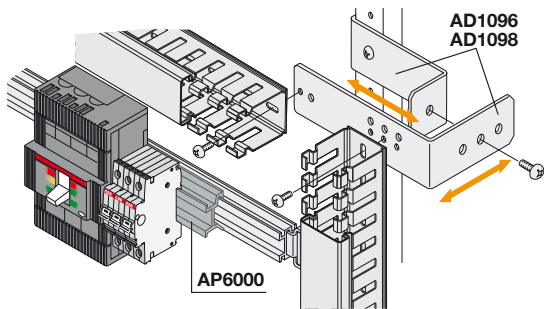

Supports for duct

Codice	Descrizione
AD1009	N°4 plastic supports for horizontal duct
AD1096	N°4 metal supports for horizontal/vertical wall-mounted duct
AD1098	N°4 metal supports for horizontal/vertical floor-standing duct

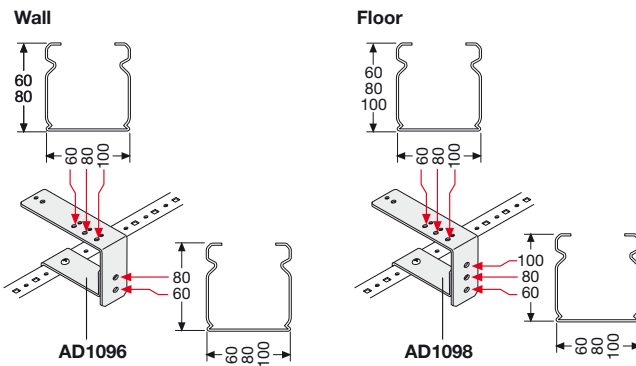

ArTu L

Kit for apparatus

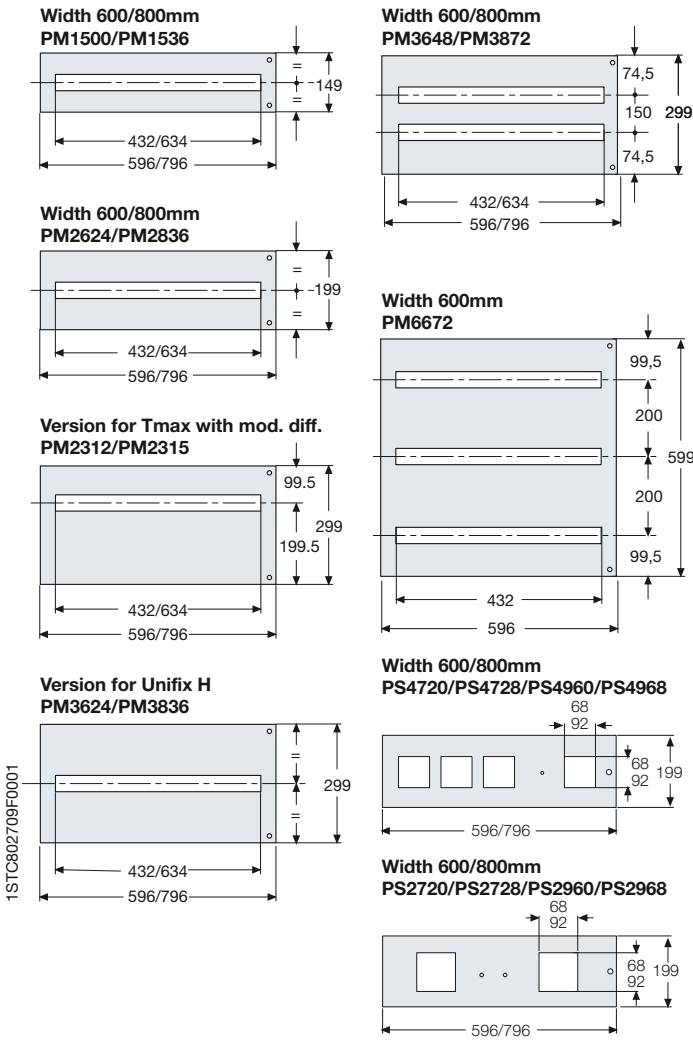

Panels for square measuring instruments

Steel sheet panels complete with hinges positioned on the right or left

Code	Description	Dimensions H (mm)
24 DIN mod 36 DIN mod W=600mm W=800mm		
PS2720 PS2728	Panel for 2 instruments 72x72mm	200
PS2960 PS2968	Panel for 2 instruments 96x96mm	200
PS4720 PS4728	Panel for 4 instruments 72x72mm	200
PS4960 PS4968	Panel for 4 instruments 96x96mm	200

Modular panels

Steel sheet panels complete with hinges positioned on the right or left

Code	Description	Dimensions H (mm)
12 DIN mod 24 DIN mod 36 DIN mod W=300mm W=600mm W=800mm		
PM1500 PM1536	Modular panel 1 DIN row	150
PM2612 PM2624 PM2836	Modular panel 1 DIN row	200
PM2312 PM2315	Modular panel 1 DIN row Tmax RC	300
PM3624 PM3836	Modular panel 1 DIN row only for Unifix H	300
PM3648 PM3872	Modular panel 2 DIN rows	300
PM6672	Modular panel 3 DIN rows	600

Accessories for panels

Code	Description
AD1086	N°10 holes covers W=2000mm grey RAL 7035 colour
AD1088	N°3 holes covers 36 Din modules grey RAL 7035 colour
AD1089	N°3 holes covers 36 Din modules grey RAL 7035 colour
EV1135	N°10 closing caps for instrument panel 72x72mm
EV1136	N°5 closing caps for instrument panel 96x96mm
AD1600	N°20 label-holders 24 DIN mod.
AD1800	N°20 label-holders 36 DIN mod.
AD1101 ⁽¹⁾	N°288 labels 1 mod. 15x17mm (HxW)
AD1102 ⁽¹⁾	N°192 labels 2 mod. 15x27mm (HxW)
AD1103 ⁽¹⁾	N°96 labels 3 mod. 15x50mm (HxW)
AD1104 ⁽¹⁾	N°96 labels 4 mod. 15x67mm (HxW)

⁽¹⁾ Labels can be written with Grafoplast compatible plotter system.

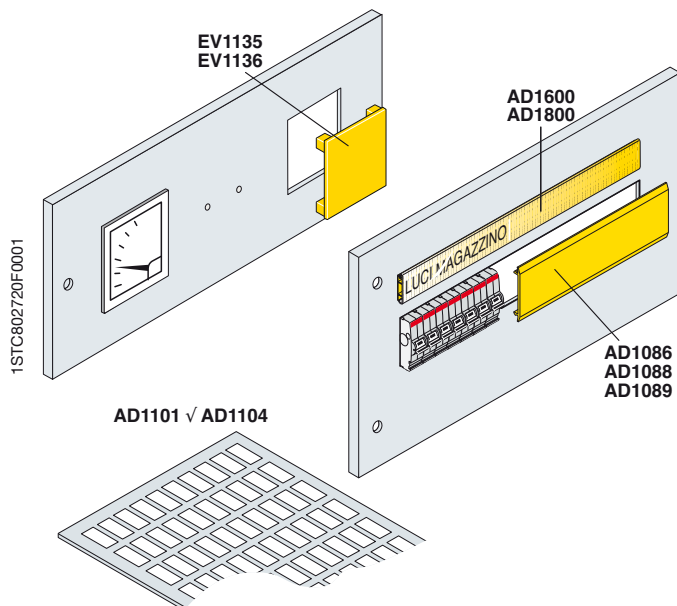

ArTu L

Kit for apparatus

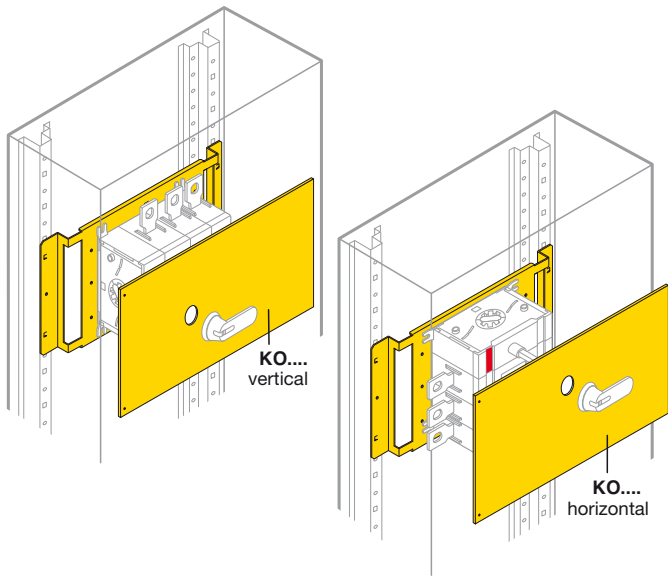

Kit for OT200/250/315/400

Code	Description	Dimensions H (mm)		
External				
24 DIN mod 36 DIN mod cable cont.				
W=600mm W=800mm W=300mm				
KO1260	KO1280	KO1262	Kit for vertical OT200/250/315/400	300
KO1261	KO1281		Kit for horizontal OT200/250/315/400	300

Standard blind for general apparatus

Code	Description	Dimensions H (mm)		
External				
24 DIN mod 36 DIN mod cable cont.				
W=600mm W=800mm W=300mm				
PF1002	PF1102		Blind back plate	200
PF1003	PF1103		Blind back plate	300
PF1004	PF1104		Blind back plate	400
PF1006	PF1106		Blind back plate	600
PF1008	PF1108		Blind back plate	800
PC0600	PC0300		Blind back plate box/cable container	300

The panels must be ordered separately.

Standard blind, recessed and ventilated panels for general apparatus

Code	Description	Dimensions H (mm)	
External			
24 DIN mod 36 DIN mod cable cont.			
W=600mm W=800mm W=300mm			
	PC1403	Blind panel for external cable container	100
	PC2401	Blind panel for external cable container	200
	PC3401	Blind panel for external cable container	300
	PC4401	Blind panel for external cable container	400
	PC6401	Blind panel for external cable container	600
	PR4401	Blind panel for external cable container	400
	PC8401	Blind panel for external cable container	800
PC1050	PC0580	Blind panel	50
PC1600	PC1800	Blind panel	100
PC1150	PC1580	Blind panel	150
PC2600	PC2800	Blind panel	200
PC3600	PC3800	Blind panel	300
PC4600	PC4800	Blind panel	400
PC6600	PC6800	Blind panel	600
PC8600	PC8800	Blind panel	800
PC1660	PC1680	Blind panel (Inner door)	1600
PC1860	PC1880	Blind panel (Inner door)	1800
PC2060	PC2080	Blind panel (Inner door)	2000
PR2600	PR2800	Blind recessed panel	200
PR4600	PR4800	Blind recessed panel	400
PR6600	PR6800	Blind recessed panel	600
PA1600		Ventilated panel	100
PA2600		Ventilated panel	200

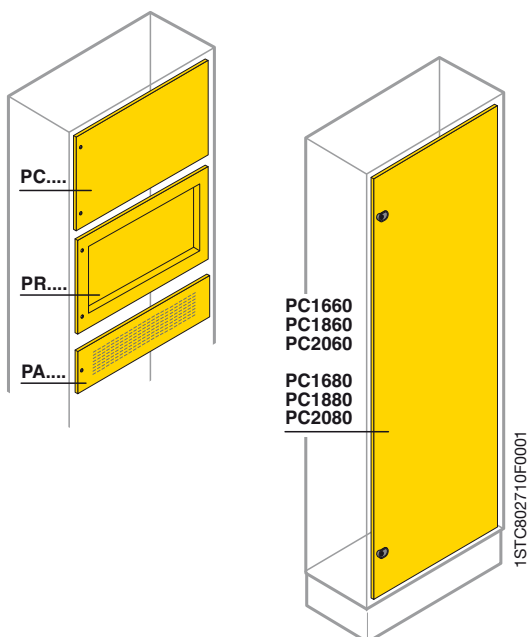
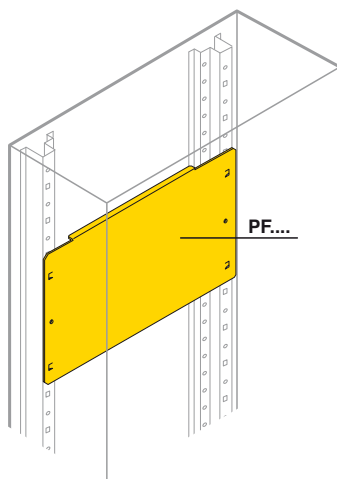

ArTu L

Kit for apparatus

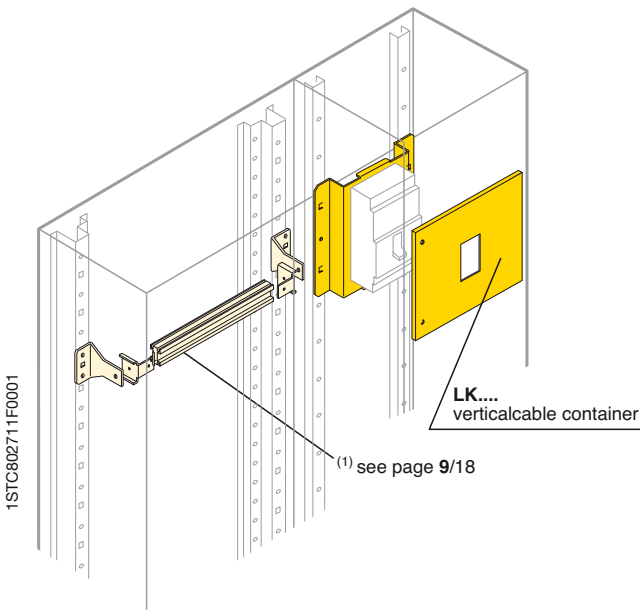
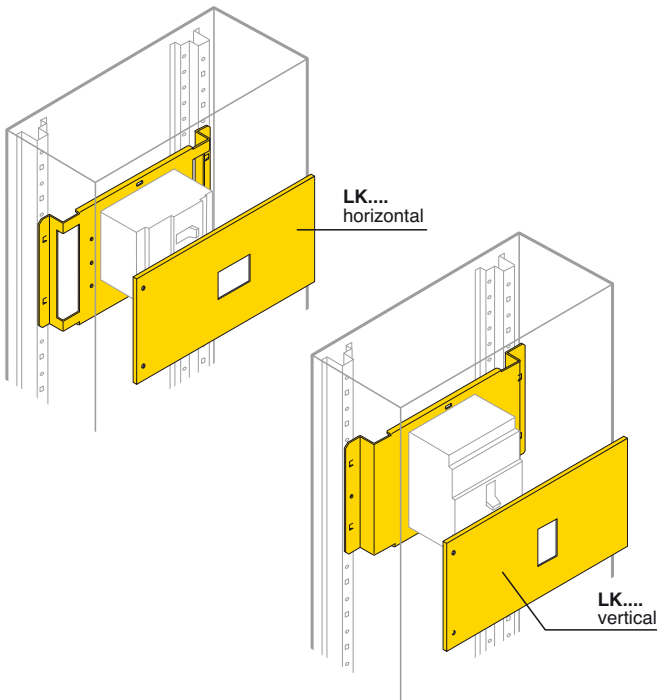

1STC802711F0001

Kits for installation of Tmax circuit-breakers

Horizontal installation (front terminals)

Code		Description	Dimensions H (mm)	
24 DIN mod W=600mm	36 DIN mod W=800mm			
Wall/Floor	Floor	Floor		
LK1000	LK1100	Kit T1 3/4 poles, fixed	200	
LK1004	LK1104	Kit T1 4 poles, fixed + RC mod.	200	
LK2000	LK2100	Kit T2 3/4 poles fixed	200	
LK2004	LK2104	Kit T2 4 poles fixed + RC mod.	200	
LK3000	LK3110	Kit T3 3/4 poles fixed	200	
LK3004	LK3104	Kit T3 4 poles fixed + RC mod.	300	
	LK3301	Kit T3 3/4 poles with divider	200	
	LK4003	LK4103	Kit T4 3/4 poles fixed	200
	LK4004	LK4104	Kit T4 4 poles fixed + RC mod.	200
	LK5003	LK5103	Kit T5 3/4 poles fixed	300
	LK5004	LK5104	Kit T5 4 poles fixed + RC mod.	300
LX1000	LX1000	LX1100	Tmax XT1 3/4 poles, fixed	200
LX1005	LX1005	LX1104	Tmax XT1 4 poles fixed + RC mod.	200
LX2000	LX2000		Tmax XT2 3/4 poles, fixed	200
LX2004	LX2004		Tmax XT2 4 poles fixed + RC mod.	200
LX3000	LX3000	LX3110	Tmax XT3 3/4 poles, fixed	200
LX3004	LX3004	LX3104	Tmax XT3 4 poles fixed + RC mod.	300
LX4003	LX4003		Tmax XT4 3/4 poles, fixed	200
LX4004	LX4004		Tmax XT4 4 poles fixed + RC mod.	200

Vertical installation (front terminals)

Code		Description	Dimensions H (mm)			
24 DIN mod W=600mm	36 DIN mod W=800mm	External cable container W=300mm				
Wall/Floor	Floor	Floor Wall Wall				
GD... ⁽¹⁾	GD... ⁽¹⁾	GD... ⁽¹⁾	Kit DIN T1-T2-T3, 3/4 poles fixed + RC mod.	150÷600		
LK1001	LK1101	LK1002	Kit T1 3/4 poles fixed	200		
		LK1008	Kit T1 4 poles fixed + RC mod.	300		
	LK4100		Kit n° 4 T1 3/4 poles side by side	200		
	LK4108		Kit n° 5 T1 3/4 poles side by side	200		
LK2001	LK2101	LK2002	Kit T2 3/4 poles fixed	200		
		LK2008	Kit T2 4 poles fixed + RC mod.	300		
	LK3200		Kit n° 3 T2 3/4 poles side by side	200		
	LK3111		Kit n° 4 T2 3/4 poles side by side	200		
LK3001	LK3101	LK3003	LK3002	Kit T3 3/4 poles fixed	300	
LK3005	LK3105	LK3008		Kit T3 4 poles fixed + RC mod.	300	
	LK3300		Kit n° 3 T3 3/4 poles side by side	300		
	LK3102		Kit n° 4 T3 3/4 poles side by side	300		
LK4005	LK4105	LK4007	Kit T4 3/4 poles fixed	400		
LK4006	LK4106		Kit T4 4 poles fixed + RC mod.	500		
LK5005	LK5105	LK5007	Kit T5 3/4 poles fixed	400		
LK5006	LK5106	LK5008	Kit T5 4 poles fixed + RC mod.	500		
	LK6011	LK6012	Kit T6 3/4 poles fixed	500		
LX1001	LX1001	LX1101	LX1002	Tmax XT1 3/4 poles, fixed	200	
LX1006	LX1006	LX1108	LX1008	Tmax XT1 CB + diff. mod.	300	
LX4100	LX4100		LX4100	Tmax XT1 N 3 CBs side by side	200	
LX3001	LX3001	LX3101	LX3003	LX3002	Tmax XT3 3/4 poles, fixed	300
LX3005	LX3005	LX3105	LX3008		Tmax XT3 CB + diff. mod.	300
LX3300	LX3300			Tmax XT3 N 2 CBs side by side	300	
LX4005	LX4005		LX4007	Tmax XT4 3/4 poles, fixed	300	
LX4006	LX4006			Tmax XT4 CB + diff. mod.	400	

for 3 poles breakers please order accessory flange code AD3305 XT1 3P Flange for plate-mounting; AD3306 XT2 3P Flange for plate-mounting; AD3307 XT3 3P Flange for plate-mounting; AD3308 XT4 3P Flange for plate-mounting

For kit Isomax see page 9/83.

ArTu L

Distribution system

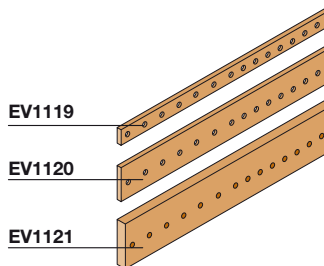
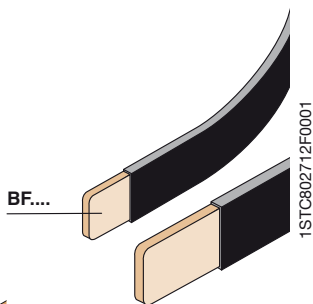
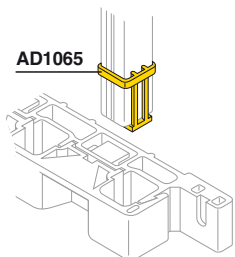
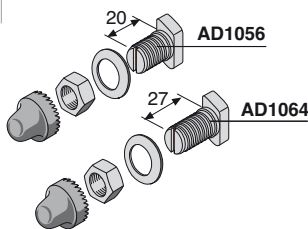
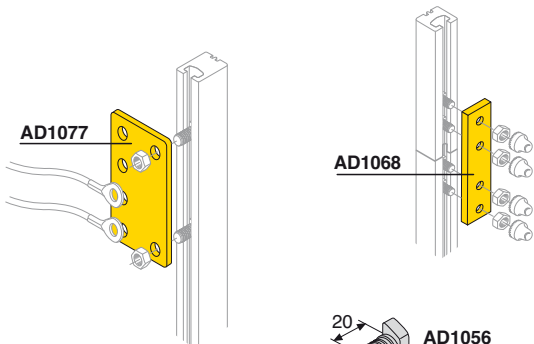
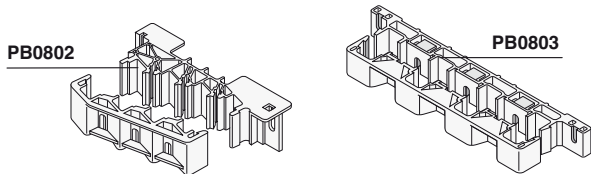
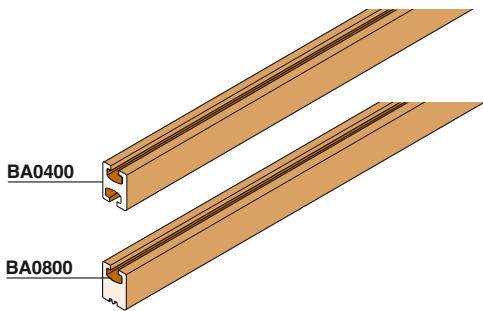

Distribution busbars with shaped section

Code	Description	Dimensions W (mm)
BA0400	Busbar In=400A	1730
BA0800	Busbar In=800A	1730

Busbar holders for busbars with shaped section

Code	Description
Scaled	
PB0802	Scaled busbar holder In=800A - 35kA
Linear	
PB0803	Linear busbar holder In=800A - 35kA

Joints for busbars with shaped section

Code	Description
AD1077	N°4 copper 400A branch joints
AD1068	N°4 joints for joining busbars with shaped section 400/800A

Hammer seal screws for busbars with shaped section

Code	Description
AD1056	N°12 M8 screws L=20mm for cable terminal complete with screw-covering cap
AD1064	N°12 M8 screws L=27mm for flat busbars up to 10mm, complete with screw-covering cap

Resting bases for busbars with shaped section

Code	Description
AD1065	N°4 resting bases for 400/800A busbars

Flexible busbars

Flexible busbars insulated with self-extinguishing material.

Code	Description	In (A)	Dimensions W (mm)
BF1602	N°2 flexible busbars, section 20x3	250	2000
BF2502	N°2 flexible busbars, section 20x5	400	2000
BF4002	N°2 flexible busbars, section 24x6	500	2000
BF4012 ⁽¹⁾	N°2 flexible busbars, section 32x5	630	2000

⁽¹⁾ Only for circuit-breakers with front extended terminals or rear terminals

Earthing busbars

Copper busbars drilled and threaded for rapid connection of the conductors.

Code	Description	Dimensions W (mm)
EV1119	N°2 earthing busbars 20x5 threaded M6	2000
EV1120	N°2 earthing busbars 25x5 threaded M6	2000
EV1121	N°2 earthing busbars 50x5 threaded M6	2000

Insulators and copper busbars for neutral/earthing

Code	Description
EV1122	N°50 hexagonal insulators 30x30mm M6
EV1123	N°50 hexagonal insulators 30x30mm M8
EV1124	N°25 hexagonal insulators 36x50mm M6
EV1125	N°25 hexagonal insulators 36x50mm M8

ArTu L

Distribution system

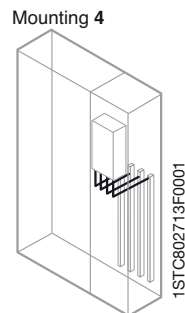
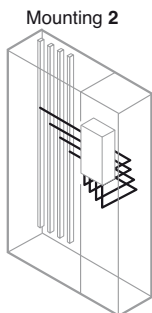
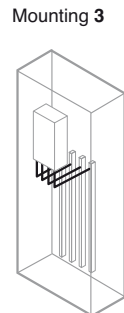
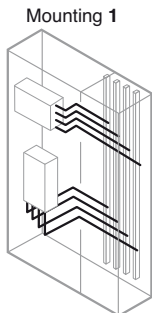
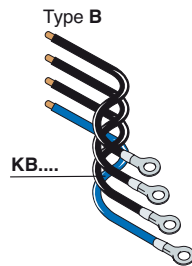
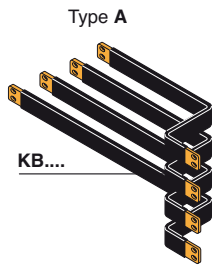
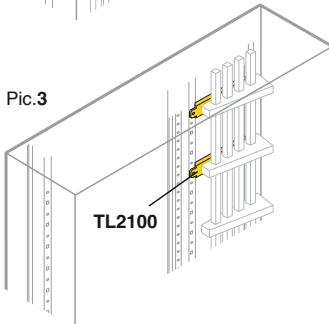
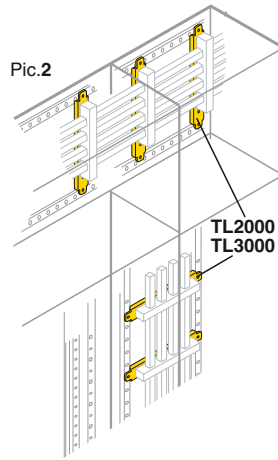
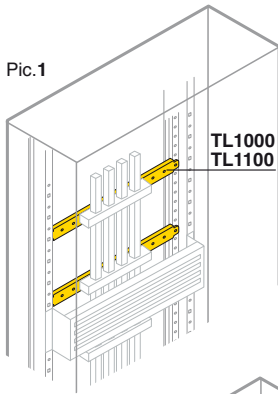

Crosspieces for 400/800A busbars with shaped section

Vertical busbars at back of structure and connection to the Unifix H system

Code	Mounting Pic.	Description
TL1000	1	N°2 Fixing crosspieces W=600mm for linear busbar holder PB0803
TL1100	1	N°2 Fixing crosspieces W=800mm for linear busbar holder PB0803

Vertical busbars at back of the external cable container or horizontal in the cable connection box

Code	Mounting Pic.	Description
TL3000	2	N°2 Fixing crosspieces W=300mm for linear busbar holder PB0803
TL2000	2	N°2 Fixing crosspieces W=300mm for scaled busbar holder PB0802

Vertical busbars at the back of the cable container internal

Code	Mounting Pic.	Description
TL2100	3	N°2 Fixing crosspieces W=200mm for scaled busbar holder PB0802

Prefabricated kit for connection between apparatus and busbars with shaped section 400/800A

Horizontal circuit-breaker

Code	Position Tmax/busbar	Structure	Mounting		
			Type	Position	
KB1001 ⁽¹⁾	T1 -T2 in the struc. and busbars in the cable cont.	floor-standing	B	1	
KB1002	T3 in the structure and busbars in the cable cont.	wall/floor-mounted	B	1	
KB1020	T5 in the structure and busbars in the cable cont.	floor-standing	B	1	
KB1021	T5 in the structure and busbars in the cable cont.	floor-standing	B	1	

Vertical circuit-breaker

Code	Position Tmax/busbar	Structure	Mounting		
			Type	Position	
KB1006	T3 in the structure and busbars in the cable container	wall/floor-mounted	B	1	
KB1022	T5 and T5 resid.cur. in the struc. and busb. in the cable cont.	floor-standing	B	1	
KB1010	T3 in the cable container and busbars in the structure	wall/floor-mounted	B	2	
KB1019	Resid. current T3 in the cable cont. and busb. in the structure	wall/floor-mounted	B	2	
KB1024	Resid. current T5 and T5 in the cab. cont. and bus. in the structure	floor-standing	B	2	
KB1014 ⁽²⁾	T3 in the structure/cable container and busbars at back	wall/floor-mounted	A	3-4	
KB1018 ⁽²⁾	T3 in the structure/cable container busbars at back	wall/floor-mounted	A	3-4	

⁽¹⁾ For Tmax T1 fit the circuit-breaker with extended terminals.

⁽²⁾ Only with flat busbars and scaled busbar holder.

ArTu L

Distribution system

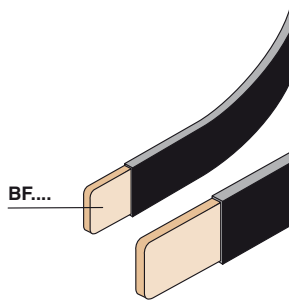
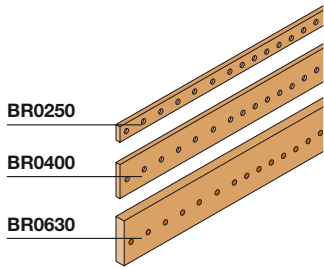

Flat busbar

Copper with 1750mm drilled length. Can be used with both linear BP0630 and scaled BP0634 busbar holder.

Code	Description	In (A)	Dimensions W (mm)
BR0250	N°2 copper busbar 15x5	250	1750
BR0400	N°2 copper busbar 25x5	400	1750
BR0630	N°2 copper busbar 30x10	630	1750

Busbars holders

Busbar holders made of insulating self-extinguishing material, certified in conformity with the EN 60439-1 Standard for $I_{cc} \leq 35kA$.

Code	Description
BP0630	N°2 linear busbar holders In=630A - 32kA
BP0632	N°2 terminal covers for linear busbar holders BP0630
BP0634	N°2 scaled busbar holder In=630A - 23kA

Flexible busbars

Flexible busbars insulated in self-extinguishing material.

Code	Description	In (A)	Dimensions W (mm)
BF1602	N°2 flexible busbars, section 20x3	250	2000
BF2502	N°2 flexible busbars, section 20x5	400	2000
BF4002	N°2 flexible busbars, section 24x6	500	2000
BF4012 ⁽¹⁾	N°2 flexible busbars, section 32x5	630	2000

⁽¹⁾ Only for circuit-breakers with front extended terminals or rear terminals

Crosspieces for flat busbars

Crosspieces for fixing the busbar holders to the structure with various installation possibilities.

Busbar vertically on back of structure or of cable container

Code	Mounting Pic.	Description
TL1000	1	N°2 crosspieces back of structure W=600mm with BP0630
TL1100	1	N°2 crosspieces back of structure W=800mm with BP0630
TL3000	2	N°2 crosspieces back of cable container W=300mm with BP0630 or scaled BP0634

Earthing busbars

Copper busbars drilled and threaded for rapid connection of the conductors.

Code	Description	Dimensions W (mm)
EV1119	N°2 earthing busbars 20x5 threaded M6	2000
EV1120	N°2 earthing busbars 25x5 threaded M6	2000
EV1121	N°2 earthing busbars 50x5 threaded M6	2000

Insulators and copper busbars for neutral/earthing

Code	Description
EV1122	N°50 hexagonal insulators 30x30mm M6
EV1123	N°50 hexagonal insulators 30x30mm M8
EV1124	N°25 hexagonal insulators 36x50mm M6
EV1125	N°25 hexagonal insulators 36x50mm M8

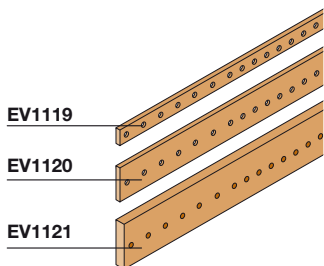
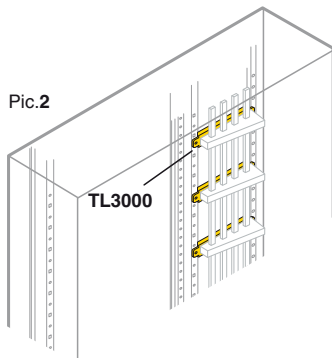
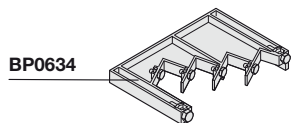
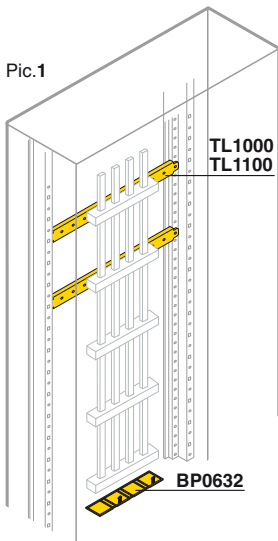
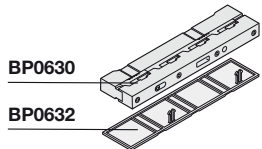

EV1122
EV1123
EV1124
EV1125

ArTu L

Distribution system

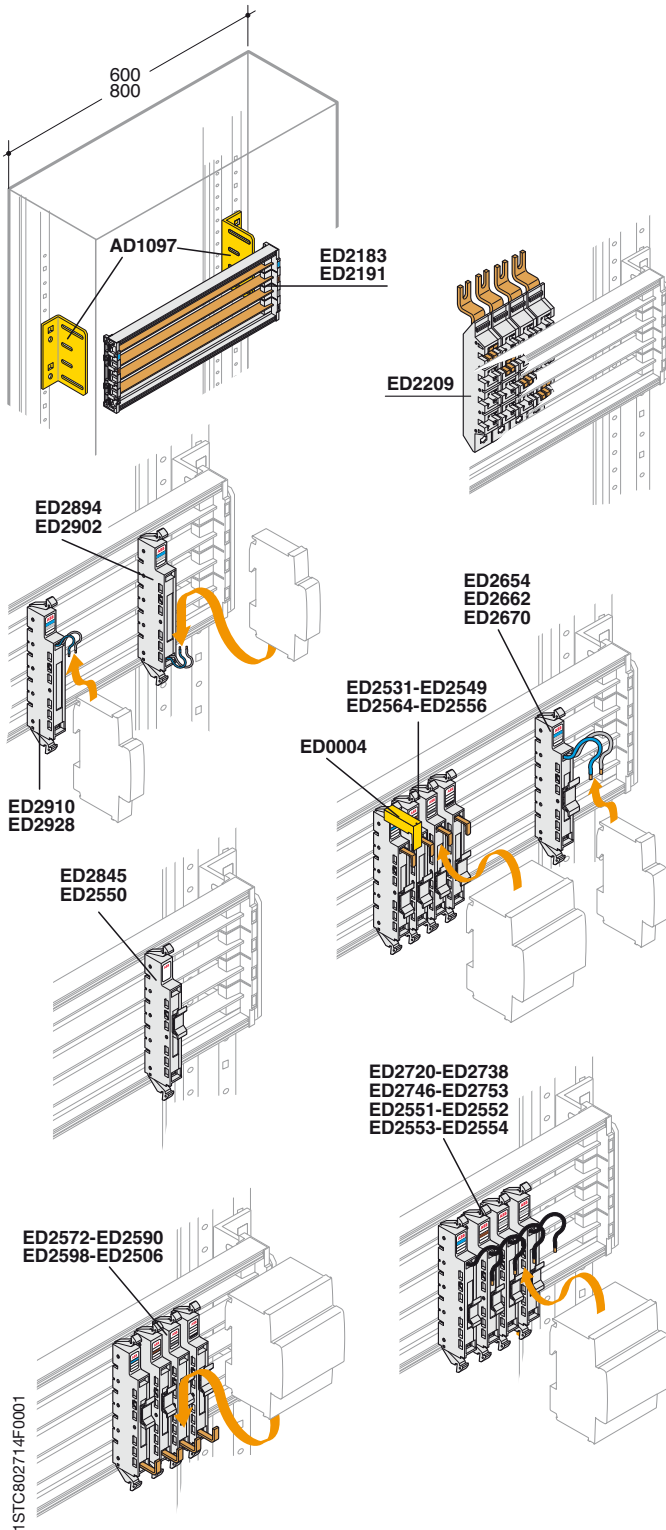

Unifix H

Frames for Tmax

Code	Description	Dimensions W (mm)
ED2183	Frame with 24 DIN module busbar	600
ED2191	Frame with 36 DIN module busbar	800
AD1097	N°2 fixing brackets onto the structure for ED2183 or ED2091	

Feeder modules

Code	Description
ED2209	4P 400A feeder module (for ED2183-ED2191)

Basic modules I_n 16A

Code	Description
ED2894	Basic module for DIN L1-N top 16A
ED2902	Basic module for DIN L1-L2 top 16A
ED2910	Basic module for DIN L1-N bottom 16A
ED2928	Basic module for DIN L1-L2 bottom 16A

Basic modules I_n 40A

Code	Description
ED2654	Basic module L1/Neutral top 40A
ED2662	Basic module L2/Neutral top 40A
ED2670	Basic module L3/Neutral top 40A

Basic modules I_n 63A

Code	Description
ED2531	Basic module L1 top 63A
ED2549	Basic module L2 top 63A
ED2556	Basic module L3 top 63A
ED2564	Basic module Neutral top 63A
ED2572	Basic module L1 bottom 63A
ED2590	Basic module L2 bottom 63A
ED2598	Basic module L3 bottom 63A
ED2606	Basic module Neutral bottom 63A

Basic modules I_n 100A

Code	Description
ED2720	Basic module with cable L1 top 100A
ED2738	Basic module with cable L2 top 100A
ED2746	Basic module with cable L3 top 100A
ED2753	Basic module with cable Neutral top 100A

Basic modules ≤I_n 40A S800

Code	Description
ED2557	Basic module L1 top ≤40A
ED2558	Basic module L2 top ≤40A
ED2559	Basic module L3 top ≤40A
ED2560	Basic module Neutral top ≤40A

Basic modules I_n 125A S800

Code	Description
ED2551	Basic module L1 top 125A
ED2552	Basic module L2 top 125A
ED2553	Basic module L3 top 125A
ED2554	Basic module Neutral bottom 125A
ED2550	Basic module false pole W=27mm

ArTu L

Distribution system

ED2217-ED2225
ED2233-ED2241
ED2258-ED2266
ED2274-ED2282
ED2332-ED2340
ED2357-ED2365

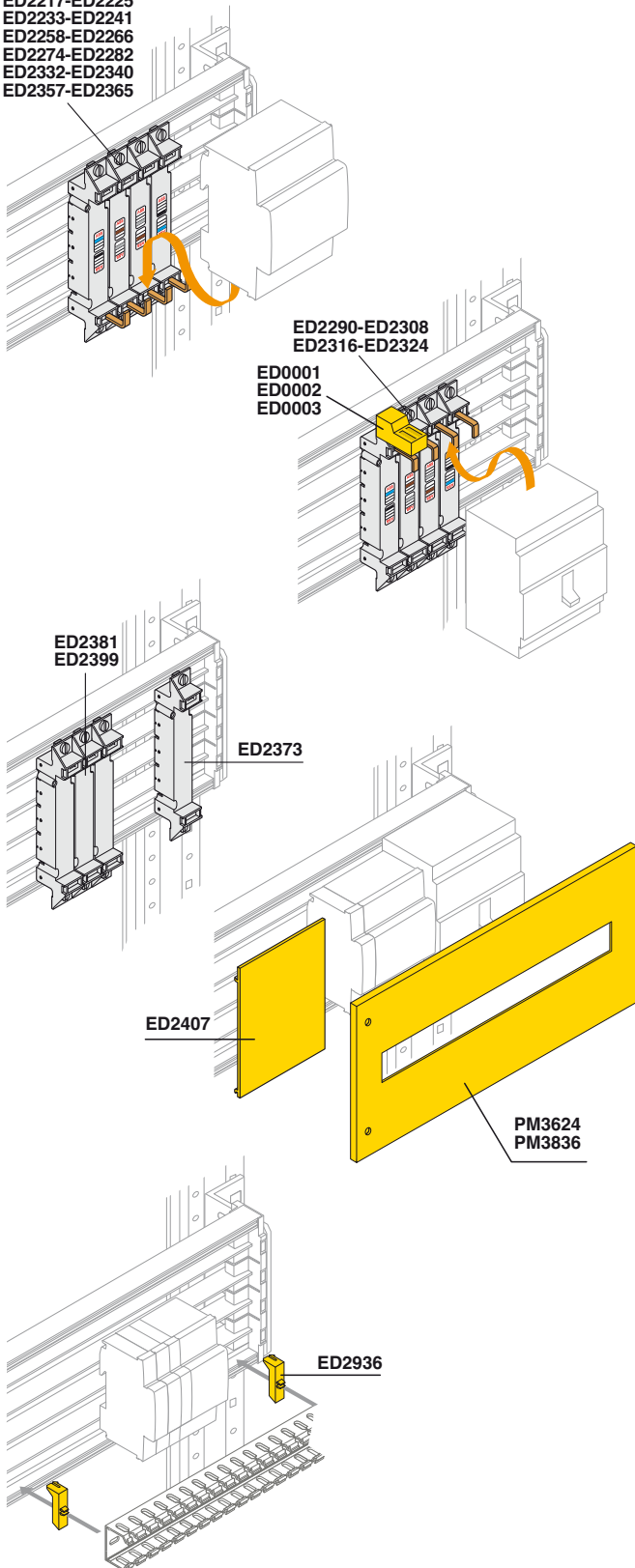

Unifix H

Basic modules I_n 160A Tmax T1

Code	Description
ED2217	Basic module L1 top L2 bottom
ED2225	Basic module L2 top L1 bottom
ED2233	Basic module L3 top Neutral bottom
ED2241	Basic module Neutral top L3 bottom
ED2373	Basic module false pole for residual current release RC221
ED2381	Basic module false pole for solenoid operator

Basic modules I_n 160A Tmax T2

Code	Description
ED2258	Basic module L1 top L2 bottom
ED2266	Basic module L2 top L1 bottom
ED2274	Basic module L3 top N bottom
ED2282	Basic module N top L3 bottom
ED2373	Basic module false pole for residual current release RC221
ED2399	Basic module false pole for solenoid operator

Basic modules I_n 250A Tmax T3

Code	Description
ED2290	Basic module L1 top
ED2308	Basic module L2 top
ED2316	Basic module L3 top
ED2324	Basic module N top
ED2332	Basic module L1 bottom
ED2340	Basic module L2 bottom
ED2357	Basic module L3 bottom
ED2365	Basic module N bottom
ED2373	Basic module false pole for residual current release RC221

Accessories

Code	Description
ED2845	Basic module false pole for DDA
ED2852	Basic module false pole for modular MDRC
ED2407	N°2 IP20 covers (for ED2183-ED2191) W=173mm (10 DIN modules)
ED2936	N°6 duct supports 40x60mm (only for modular apparatus)
PM3624	Modular front panel 300x600mm (HxL)
PM3836	Modular front panel 300x800mm (HxL)

Spare parts

Code	Description
ED0001	N°10 terminal covers for T1
ED0002	N°10 terminal covers for T2
ED0003	N°10 terminal covers for T3
ED0004	N°10 terminal covers for S200/F200

ArTu L

Distribution system

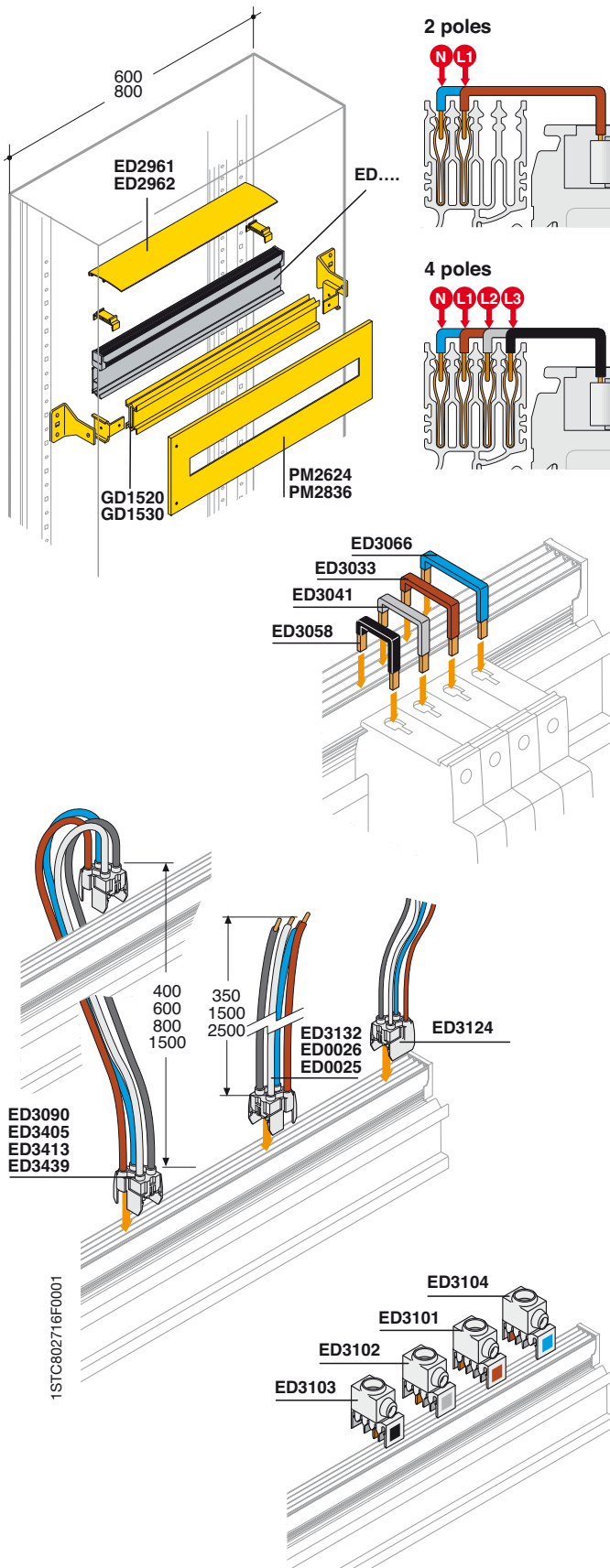

Unifix L

2-pole busbars

Code	Description	Dimensions W (mm)
ED2985	100A 2P 8 module busbar	200
ED2993	100A 2P 12 module busbar	400
ED3009	100A 2P 18 module busbar	450
ED3017	100A 2P 24 module busbar	600
ED3025	100A 2P 36 module busbar	800

4-pole busbars

Code	Description	Dimensions W (mm)
ED2944	100A 4P 12 module busbar	400
ED2951	100A 4P 18 module busbar	450
ED2969	100A 4P 24 module busbar	600
ED2977	100A 4P 36 module busbar	800

Connections for various apparatus

Code	Description
ED3108	Connection with 2 conductors L/N 16A
ED3116	Connection with 3 conductors L1/L2/L3 16A
ED3124	Connection with 4 conductors L1/L2/L3/N 16A single phase
ED3355	Connection with 2 conductors L1/N 40A
ED3363	Connection with 3 conductors L1/L2/L3 40A
ED3371	Connection with 4 conductors L1/L2/L3/N 40A

Connections for apparatus

Code	Description
ED3272	N°10 connections L1-N 40 A
ED3280	N°10 connections L2-N 40 A
ED3298	N°10 connections L3-N 40 A
ED3033	N°10 connections L 1 100A
ED3041	N°10 connections L 2 100A
ED3058	N°10 connections L 3 100A
ED3066	N°10 connections N 100A
ED3132	Feeder with 4P 100A cable (W=350mm)
ED0026	Feeder with 4P 100A cable (W=1500mm)
ED0025	Feeder with 4P 100A cable (W=1500mm)

Power supply modules with cable

Code	Description	Dimensions W (mm)
ED3082	Parallel module 2P 100A with cable	600
ED3405	Parallel module 4P 100A with cable	400
ED3090	Parallel module 4P 100A with cable	600
ED3413	Parallel module 4P 100A with cable	800
ED3439	Parallel module 4P 100A with cable	1500

Power supply modules without cable in 100A

Code	Description
ED3101	N°10 single-pole power supply terminals L1
ED3102	N°10 single-pole power supply terminals L2
ED3103	N°10 single-pole power supply terminals L3
ED3104	N°10 single-pole power supply terminals N

Accessories

Code	Description	Dimensions W (mm)
ED2961	N°10 busbar covers	600
ED2962	N°2 busbar covers	800
GD1520	DIN rail Kit and supports	600
GD1530	DIN rail Kit and supports	800
PM2624	Modular front panel 200x600mm (HxW)	
PM2836	Modular front panel 200x800mm (HxW)	

ArTu L

Accessories

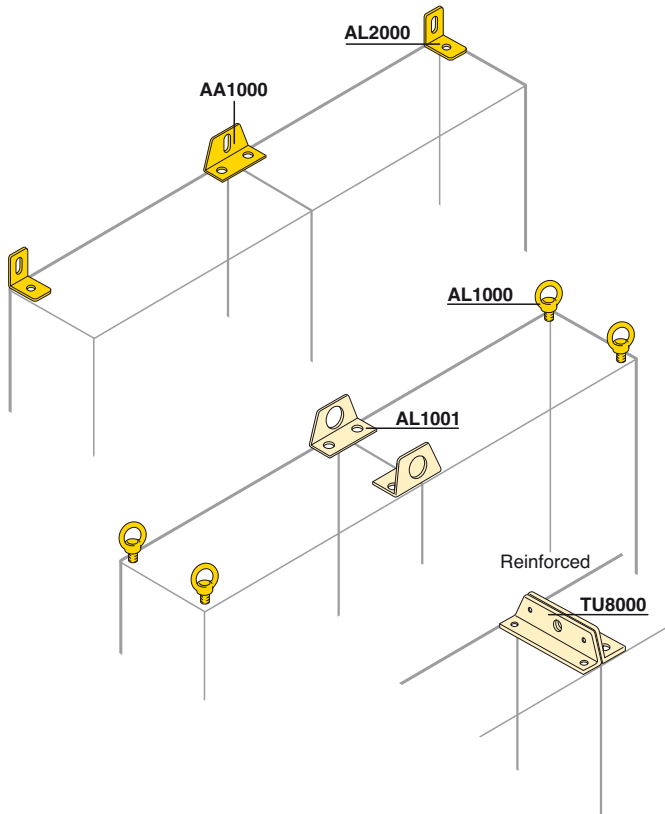

Brackets for wall fixing

Code	Description
AL2000	N°2 brackets for wall fixing
AA1000	Bracket for wall fixing of 2 side-by-side structures

For the wall-mounted version, order 2 x AL2000.

Eyebolts and lifting reinforcements

Code	Description
AL1000	N°4 M8 steel eyebolts
AL1001	N°2 lifting reinforcements for side-by-side structures W=300/600mm
TU8000	N°2 lifting/coupling reinforcements
TS4000	N°2 cable rails W=600mm
TS4001	N°2 cable rails W=800mm
TS4002	N°2 cable rails W=1000mm
TS4003	N°2 cable rails W=1200mm

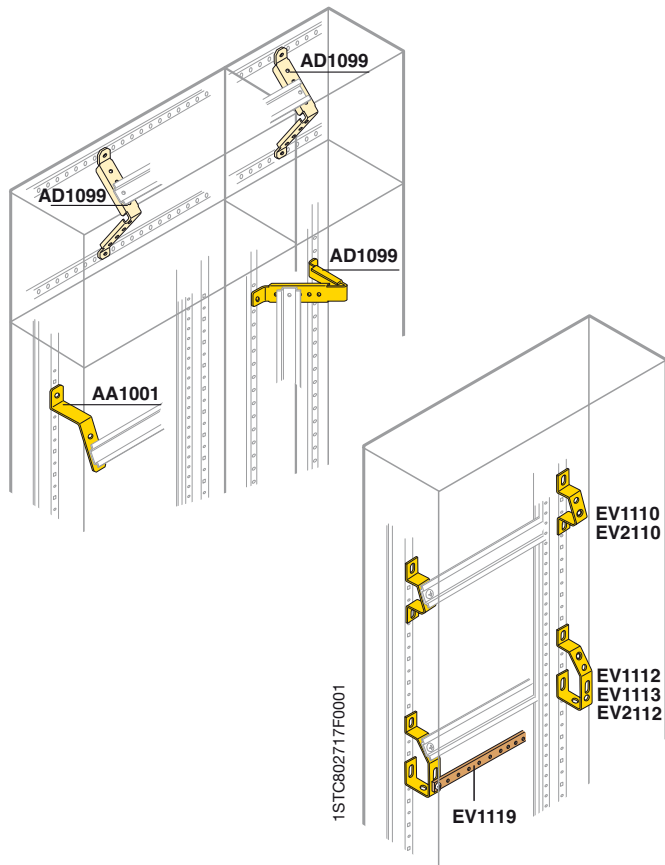

Supports for terminal boxes

Structure

Code	Description
AA1001	N°2 supports for horizontal 45° angled terminal box

Cable container

Code	Description
AD1099	N°2 supports for vertical terminal box in external cable container or horizontal in the cable connection box
AD1005	N°2 supports for vertical terminal box in internal cable container

Angled supports for terminal boxes and earthing busbars

Code	Description
EV1110	N°50 angled supports 1 row of terminals
EV2110	N°10 angled supports 1 row of terminals
EV1112	N°50 angled supports 1 row of terminals + earth
EV2112	N°10 angled supports 1 row of terminals + earth
EV1113	N°2 angled supports 1 row of terminals + earth

ArTu L

Accessories

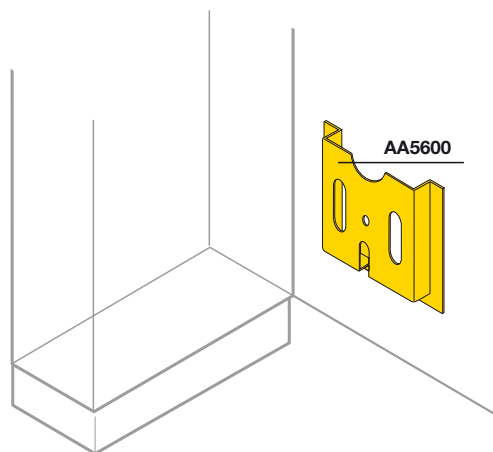

Diagram holder pocket

The diagram holder pocket (made of RAL 2004 colour plastic, dim. HxL 237x265mm type A4) is applied to the inside of doors/blind panels of suitable size using the adhesive provided.

Code	Description
AA5600	Plastic diagram pocket

Sections for accessories

Code	Description	Dimensions W (mm)
TS4011	N°2 sections EN50024 C30	2000
TS4012	N°2 sections EN50035 G32	2000
TS4013	N°2 DIN sections EN50022	2000
TS4000	N°2 cable rails	600
TS4001	N°2 cable rails	800
TS4002	N°2 cable rails	1000
TS4003	N°2 cable rails	1200

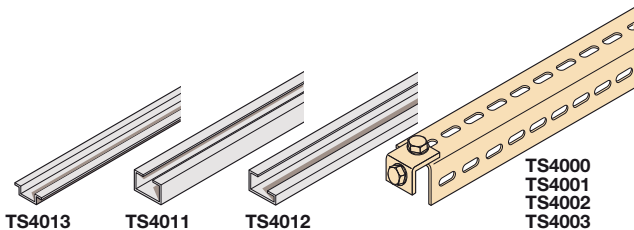

Dividers

Code	Description
	Single-pole Three-pole Four-pole
AD1076 ⁽¹⁾	AD1075 AD1004 Modular 125A
AD1080 ⁽²⁾	AD1028 Modular 125A-medium-89x93x48 (LxWxH)
	AD1029 Modular 125A-large-126x93x48 (LxWxH)
AD1007 ⁽¹⁾	AD1006 AD1027 Modular 160A
AD1081 ⁽²⁾	AD1030 Modular 250A
AD1030	AD1034 Horizontal 250A for structures W=600mm
	AD1053 Horizontal 250A for structures W=800mm
AD1031	Modular 400A

⁽¹⁾ 10 outputs
⁽²⁾ 6 outputs

Amounting accessories

Code	Description
AD1038	Supports for fixing to the structure for AD1034 and AD1053
AD1083	Connection accessory between two AD1080

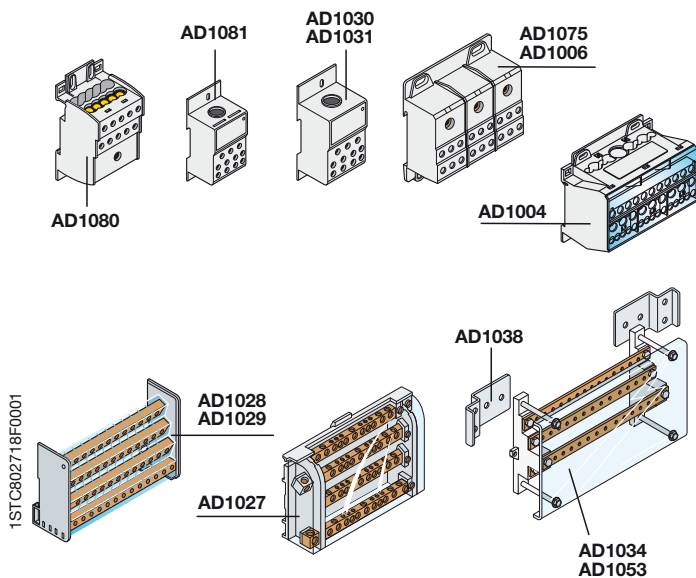

ArTu L

Accessories

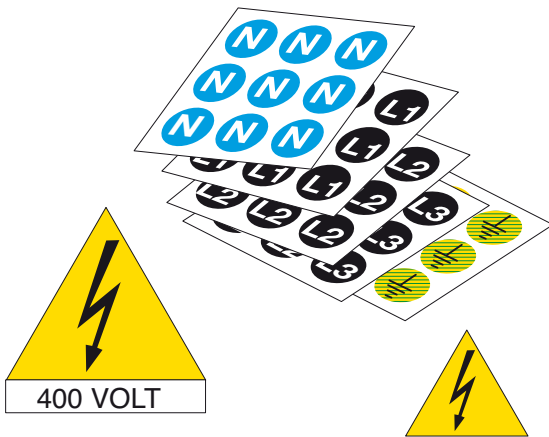

Marking

Code	Description
EV1150	N°490 adhesive labels ø12mm symbol N
EV1151	N°490 adhesive labels ø12mm symbol L1
EV1152	N°490 adhesive labels ø12mm symbol L2
EV1153	N°490 adhesive labels ø12mm symbol L3
EV1154	N°490 adhesive labels ø12mm symbol T
EV1155	N°10 triangular adhesive labels 125mm with 400V lightning arrow symbol
EV1156	N°300 triangular adhesive labels 50mm with lightning arrow symbol

Brackets for anchoring cables

Adjustable cable blocking bracket can be mounted on sections with 10mm slot EV1050.

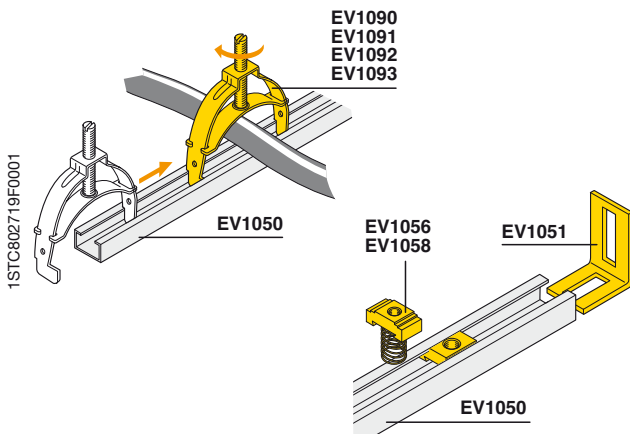

Code	Description
EV1090	N°10 cable blocking brackets min÷max ø 9÷16mm
EV1091	N°10 cable blocking brackets min÷max ø 16÷30mm
EV1092	N°5 cable blocking brackets min÷max ø 30÷48mm
EV1093	N°5 cable blocking brackets min÷max ø 48÷72mm

Aluminium sliding guides for universal uses

Code	Description
EV1050	N°10 aluminium supporting sections 30x15 - W=2000mm
EV1051	N°25 fixing brackets for EV1050
EV1056	N°100 aluminium M6 nuts for EV1050
EV1058	N°100 aluminium M8 nuts for EV1050

ArTu L Accessories

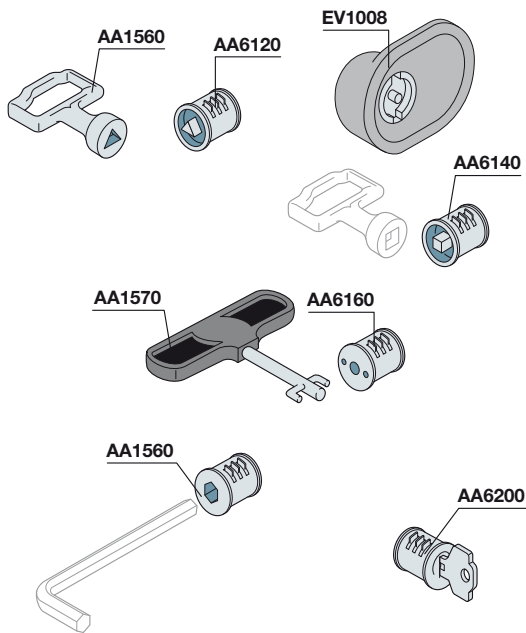

Insert and keys

Code	Description
Wall-mounted structures and cable container	
EV1008	Box for closing doors with double-tab insert
EV1036	ArTu W wall-mounted insert + Yale type key
EV1037	Ronis 455 Insert + key for EV1008
EV1039	3mm double-tab insert + key for EV1008
Floor-mounted structures	
AA6100	Double-tab insert
AD1058	Double-tab Zn+Al+Mg alloy key
AA6200	Yale insert + key
AA6120	Male 6.4 triangular insert on \varnothing 7.6
AA1560	Triangular key
AA6140	Male 7square type insert; key not available
AA6180	Hexagonal 8 type insert embedded; key not available
AA6160	FIST type insert (FIAT)
AA1570	Fiat key
AA8004	Ronis E739 insert + key

Accessories

Code	Description
AD1036	N°20 cage nuts
VB7035	Spray paint for touching up RAL 7035 colour (400 ml can)

Spare parts

Code	Description
AD1090	N°10 hinges + screws for panels (spare part ACP468)
AD1091	N°10 plug + door key kits (spare part APT002)
AD1022	ArTu handle complete with lock and cover
AD1070	N°10 Artu handle covers
AD1033	N°50 three-lobed M6 spare screws

ArTu M Structure

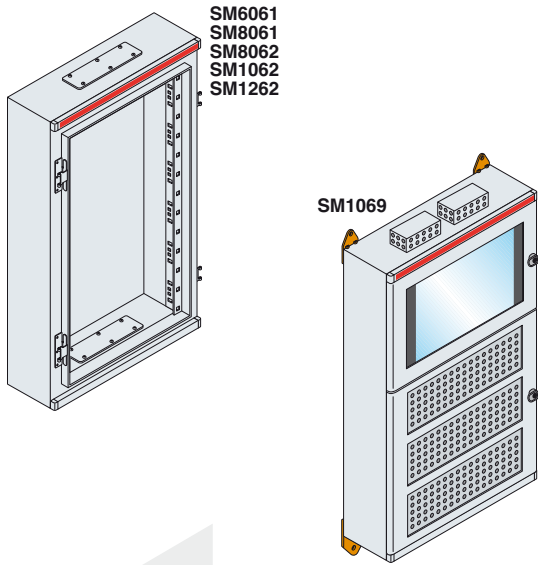
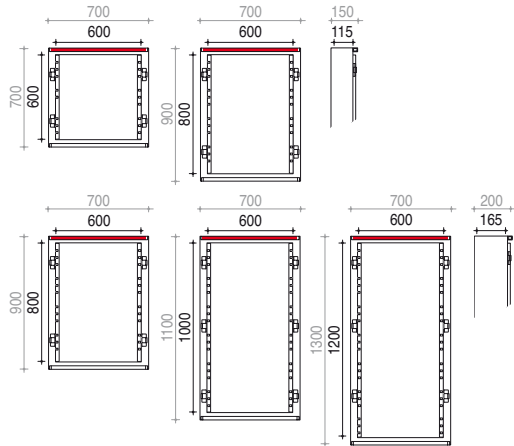

ArTu M wall-mounted structures

Basic version

Code	Description	Useful dimensions HxD (mm)
24 DIN mod W=600mm		
SM6061	Monobloc structure	600x115
SM8061	Monobloc structure	800x115
SM8062	Monobloc structure	800x165
SM1062	Monobloc structure	1000x165
SM1262	Monobloc structure	1200x165

IP40 version for operating theatre

Code	Description	Useful dimensions HxD (mm)
24 DIN mod W=600mm		
SM1069	Monobloc structure for constructing switchgear for operating theatres	1000x165

The QSO switchgear for operating theatres are complete with brackets (AD1009 n° 4 pieces) for installation of the duct, two DIN rail kits (GD6001 and PM2624 n° 2 pieces) and relative wall fixing brackets (4 pieces).

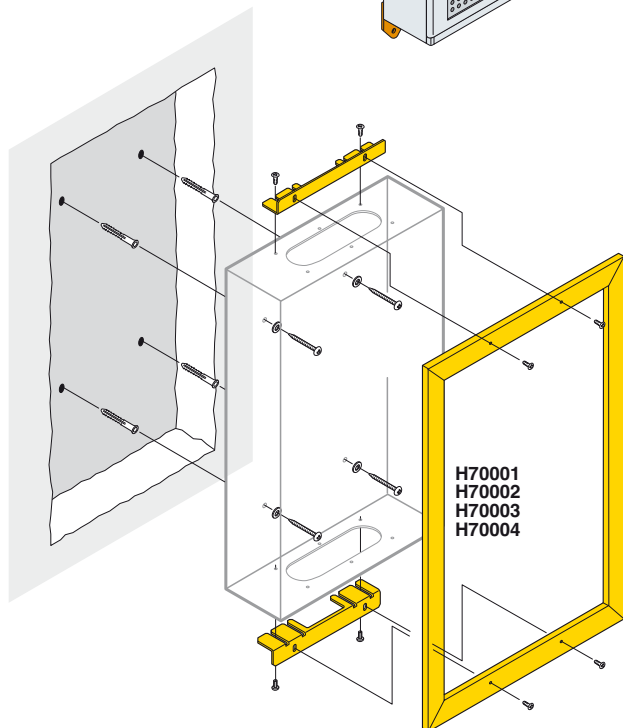

Embedding frame

Code	Description	Dimensions HxW (mm)
H70001	Frame and squares for embedding structure	600x600
H70002	Frame and squares for embedding structure	800x600
H70003	Frame and squares for embedding structure	1000x600
H70004	Frame and squares for embedding structure	1200x600

1STC802721F0001

ArTu M Structure

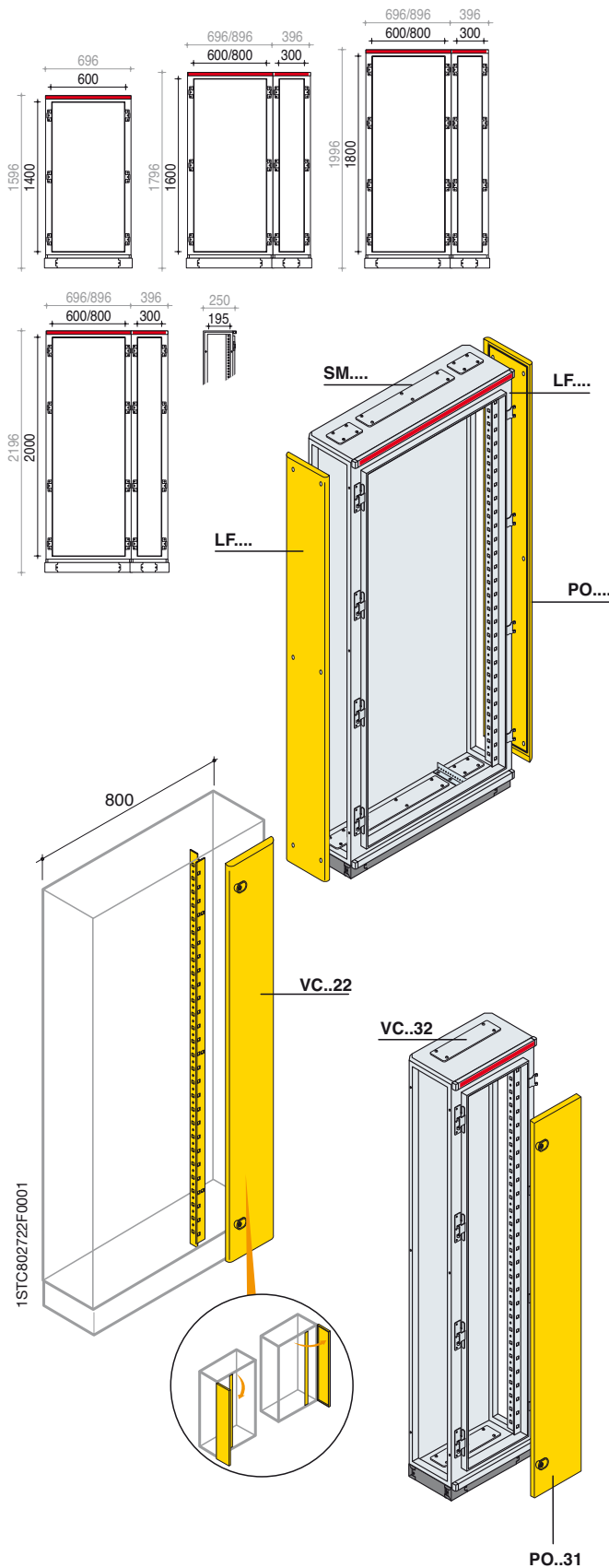

ArTu M floor-standing structures

Basic version

Code	Description	Dimensions HxD (mm)	
24 DIN mod 36 DIN mod W=600mm W=800mm			
SM1462	Floor standing monobloc structure	1400x195	
SM1662	SM1682	Floor standing monobloc structure	1600x195
SM1862	SM1882	Floor standing monobloc structure	1800x195
SM2062	SM2082	Floor standing monobloc structure	2000x195

Additional cable container for floor-mounted structures

Only to be ordered for the 36 DIN mod. structures (W=800mm).
Consisting of a functional upright and a blind door complete with two key locks.
Can be mounted either on the right or left.

Internal cable container for structure 36 mod. (W=800mm)

Code	Description	Dimensions HxWxD (mm)
VC1622	Internal cable container for structure SM1682	1600x200x195
VC1822	Internal cable container for structure SM1882	1800x200x195
VC2022	Internal cable container for structure SM2082	2000x200x195

External cable container

Can be mounted either on the right or left.

Code	Description	Dimensions HxWxD (mm)
VC1632	External cable container	1600x300x195
VC1832	External cable container	1800x300x195
VC2032	External cable container	2000x300x195

The additional cable container can be completed in the following ways:
-IP65 version with external door (internal optional) (see page 34).
-IP31 version with internal door and finishing section (see page 35).

IP65 side panels for structures and additional cable container

Code	Description	Dimensions HxD (mm)
LF1425	N°2 floor-standing side panels	1400x195
LF1625	N°2 floor-standing side panels	1600x195
LF1825	N°2 floor-standing side panels	1800x195
LF2025	N°2 floor-standing side panels	2000x195

Front coverings IP31 for additional cable container

Code	Description	Dimensions HxW (mm)
PO1631	Internal door for additional cable container	1600x300
PO1831	Internal door for additional cable container	1800x300
PO2031	Internal door for additional cable container	2000x300

ArTu M Structure

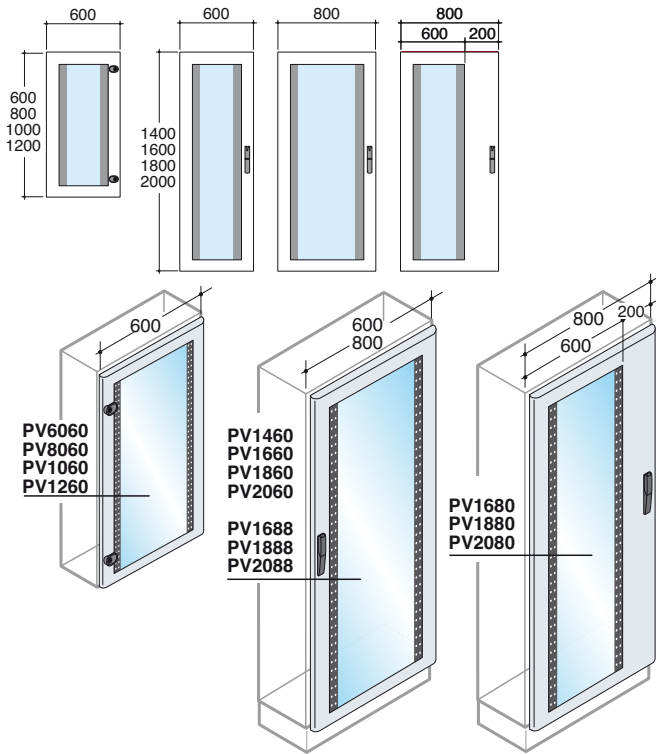

IP65 front doors for structures

Glass door 24/36 mod.

Door made of 15/10 thick steel sheet with 4 mm thick safety glass fitted with polyurethane gasket complete with handle with key with double tab. Reversible, can be hinged on the right or left.

Code	Description	Dimensions H (mm)		
36 DIN mod+ internal cable cont.				
24 DIN mod W=600mm	36 DIN mod W=800mm	36 DIN mod+ internal cable cont. W=800mm		
PV6060	Wall-mounted IP65 glass door	600		
PV8060	Wall-mounted IP65 glass door	800		
PV1060	Wall-mounted IP65 glass door	1000		
PV1260	Wall-mounted IP65 glass door	1200		
36 DIN mod+ external cable cont.				
PV1460	Floor-standing IP65 glass door	1400		
PV1660	PV1688	PV1680	Floor-standing IP65 glass door	1600
PV1860	PV1888	PV1880	Floor-standing IP65 glass door	1800
PV2060	PV2088	PV2080	Floor-standing IP65 glass door	2000

ArTu M

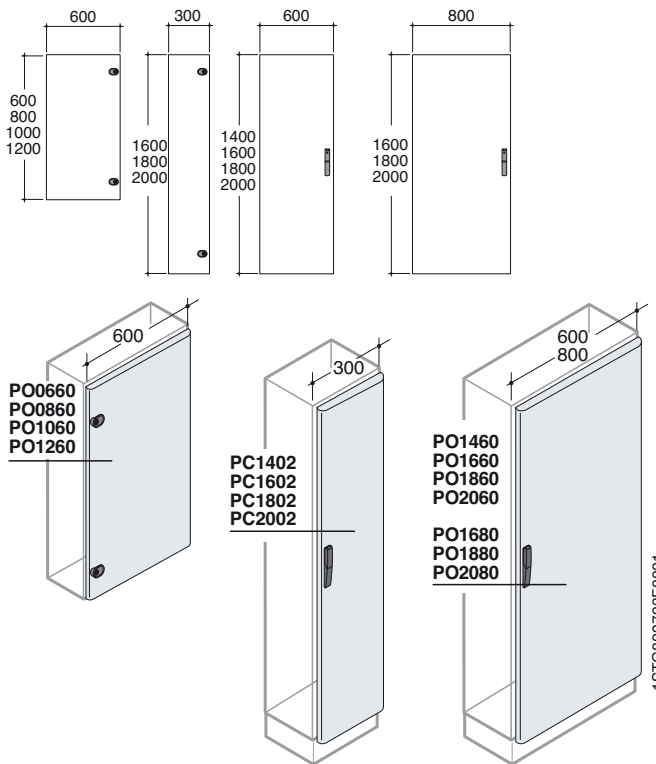

Blind door

Code	Description	Dimensions H (mm)		
External cable cont.				
24 DIN mod W=600mm	36 DIN mod W=800mm	External cable cont. W=300mm		
PO6060	Wall-mounting IP65 blind door	600		
PO8060	Wall-mounting IP65 blind door	800		
PO1060	Wall-mounting IP65 blind door	1000		
PO1260	Wall-mounting IP65 blind door	1200		
36 DIN mod+ external cable cont.				
PO1460	Floor-standing IP65 blind door	1400		
PO1660	PO1680	PO1630	Floor-standing IP65 blind door	1600
PO1860	PO1880	PO1830	Floor-standing IP65 blind door	1800
PO2060	PO2080	PO2030	Floor-standing IP65 blind door	2000

1STC802723F0001

ArTu M Structure

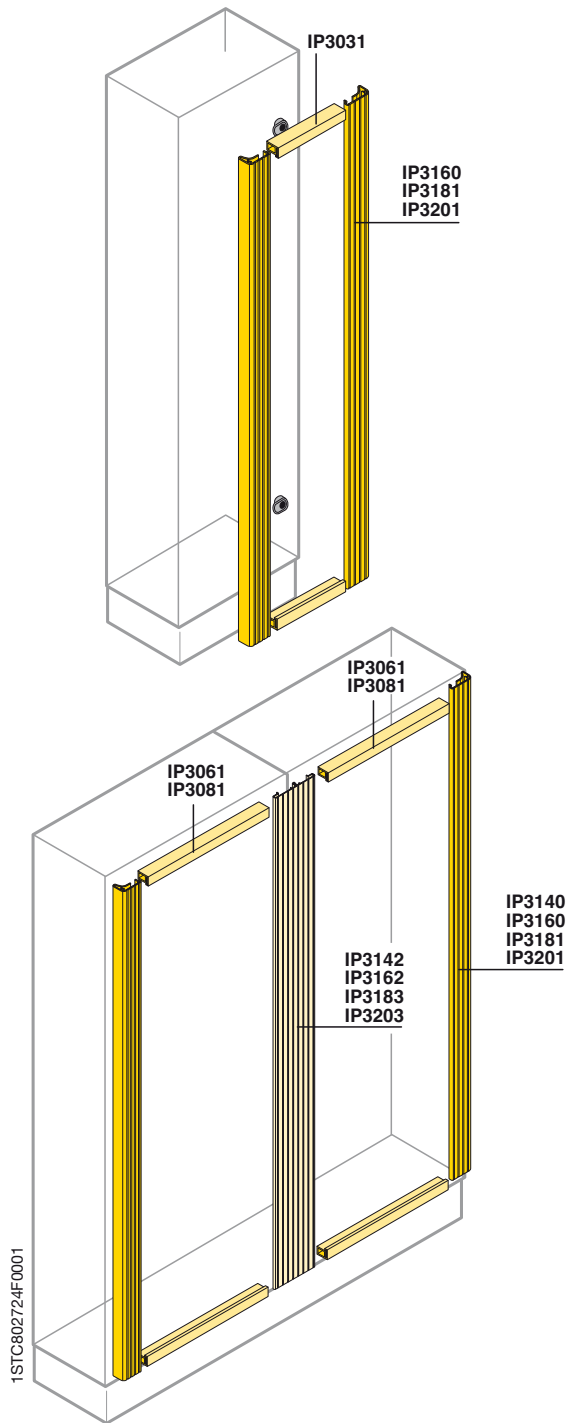

IP31 finishing section

Vertical section

Code		Description			
Dimensions H (mm)					
	1400	1600	1800	2000	
IP3140	IP3160	IP3181	IP3201	N°2 IP31 vertical finishing sections	
IP3142	IP3162	IP3183	IP3203	IP31 double vertical finishing section	

For IP31 version switchgear (without door), use the special finishing kits already sized for the standard heights and widths of the ArTu switchgear. In the case of switchgear side by side, use the special IP31 double kit on the joining uprights.

Horizontal sections for structures and cable container

Code		Description		
		External cable cont.		
		24 DIN mod	36 DIN mod	
		W=600mm	W=800mm	W=300mm
IP3061	IP3081	IP3031	N°2 IP31 horizontal finishing sections	

ArTu M

Kit for apparatus

Width 600/800mm
PM2624/PM2836

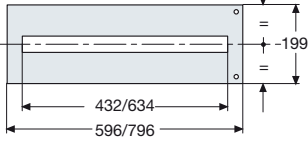

Version for Tmax with mod. diff.
PM2312/PM2315

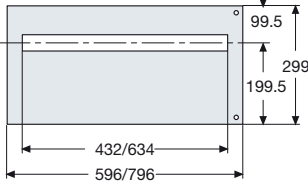

Version for Unifix H
PM3624/PM3836

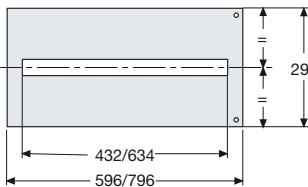

Width 600/800mm
PM3648/PM3872

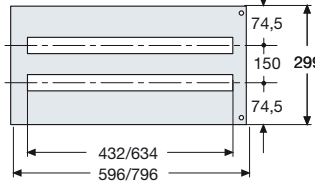

Width 600mm
PM6672

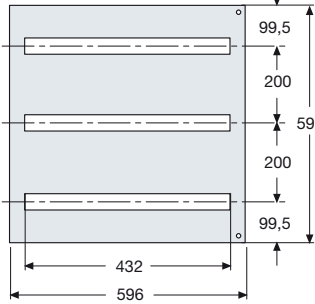

Width 600/800mm
PS4720/PS4728/PS4960/PS4968

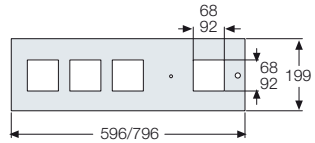

Width 600/800mm
PS2720/PS2728/PS2960/PS2968

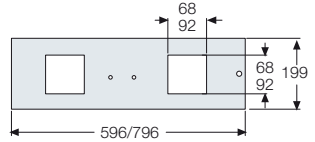

Panels for square measuring instruments

Steel sheet panels complete with hinges placed on the right or left

Code	Description	Dimensions H (mm)
24 DIN mod 36 DIN mod W=600mm W=800mm		
PS2720 PS2728	Panel for 2 instruments 72x72mm	200
PS2960 PS2968	Panel for 2 instruments 96x96mm	200
PS4720 PS4728	Panel for 4 instruments 72x72mm	200
PS4960 PS4968	Panel for 4 instruments 96x96mm	200

Modular panels

Steel sheet panels complete with hinges placed on the right or left

Code	Description	Dimensions H (mm)
24 DIN mod 36 DIN mod W=600mm W=800mm		
PM2624 PM2836	Modular panel 1 DIN row	200
PM2312 PM2315	Modular panel 1 DIN row - Tmax RC	300
PM3624 PM3836	Modular panel 1 DIN row only for Unifix H	300
PM3648 PM3872	Modular panel 2 DIN rows interaxis 150mm	300
PM6672	Modular panel 3 DIN rows	600

ArTu M

9

Accessories for panels

Code	Description
AD1086	N°10 holes covers W=2000mm grey RAL 7035 colour
AD1088	N°3 holes covers 24 Din modules grey RAL 7035 colour
AD1089	N°3 holes covers 36 Din modules grey RAL 7035 colour
EV1135	N°10 closing caps for instrument panel 72x72mm
EV1136	N°5 closing caps for instrument panel 96x96mm
AD1600	N°20 label-holders 24 DIN mod.
AD1800	N°20 label-holders 36 DIN mod.
AD1101 ⁽¹⁾	N°288 labels 1 mod. 15x17mm (HxW)
AD1102 ⁽¹⁾	N°192 labels 2 mod. 15x27mm (HxW)
AD1103 ⁽¹⁾	N°96 labels 3 mod. 15x50mm (HxW)
AD1104 ⁽¹⁾	N°96 labels 4 mod. 15x67mm (HxW)

⁽¹⁾ Labels can be written with Grafoplast compatible plotter system.

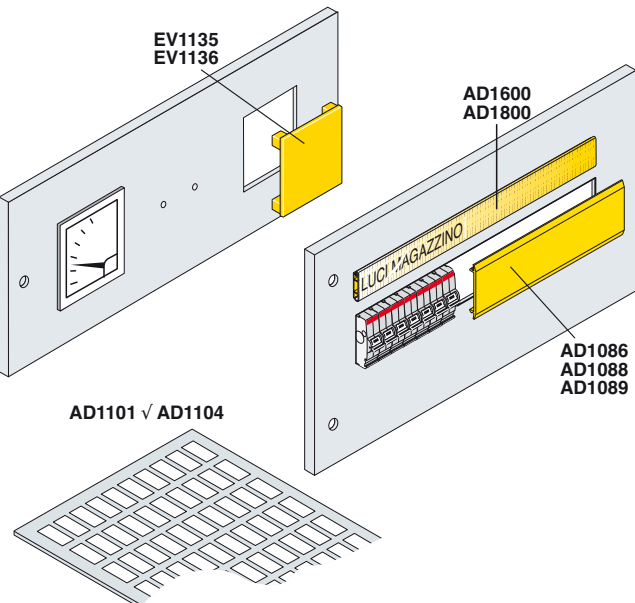

ArTu M

Kit for apparatus

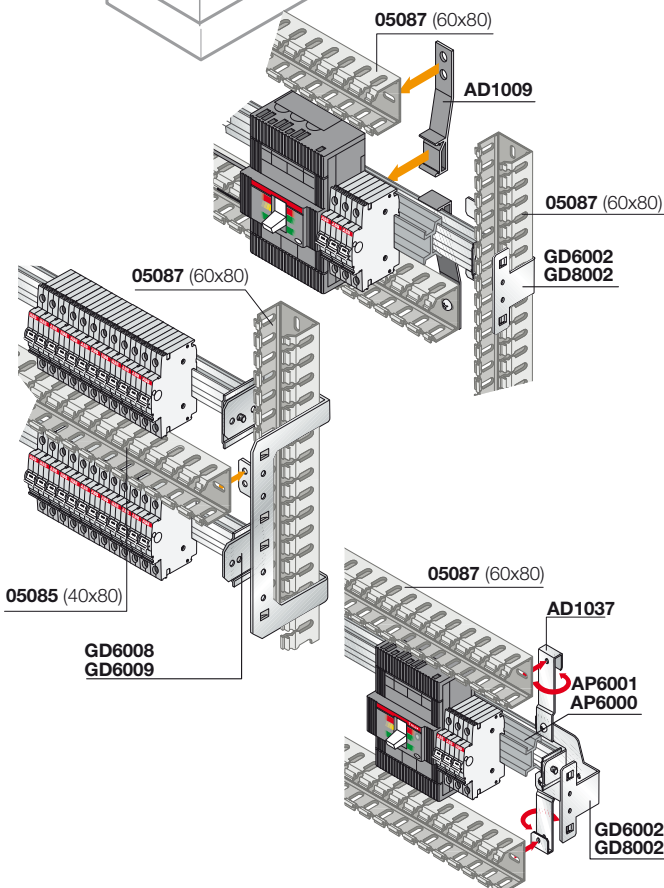
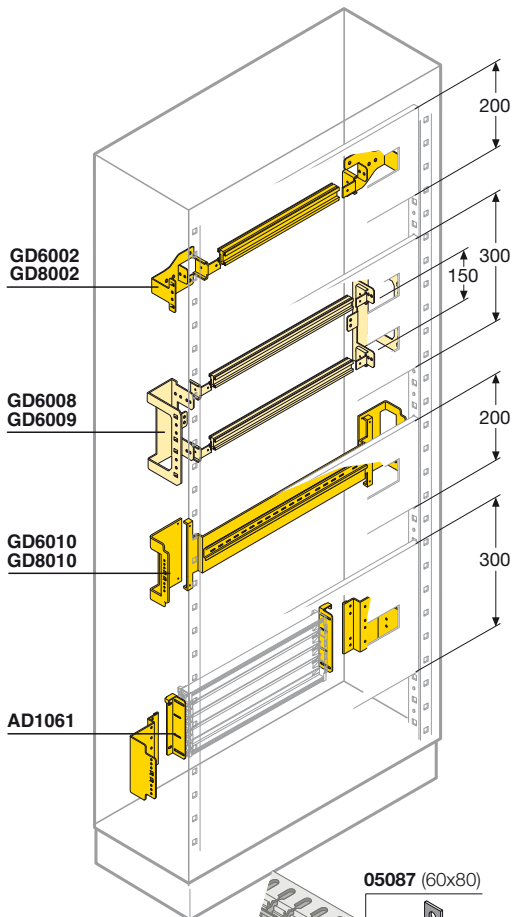

DIN rail kits for System Pro-M modular apparatus, Tmax T1-T2-T3, moulded-case circuit-breakers and supports for Unifix H

DIN rail kit

Code	Description
24 DIN mod 36 DIN mod W=600mm W=800mm	
GD6002 GD8002	DIN rail kit (aluminium)
GD6008 GD6009	DIN rail kit centre dist. 150mm (2 DIN rows)
GD6010 GD8010	DIN rail kit reinforced for Tmax RC
GC6002⁽¹⁾ GC8002⁽¹⁾	DIN rail kit with accessories

⁽¹⁾ The DIN rail kit fitted with accessories includes the 60x80 cabling duct and relative fixing supports AD1037.

Supports for Unifix H

Code	Description	Dimensions W(mm)
AD1061	Fixing supports for Unifix H series for panel H=300mm	600/800

Depth adapters

Code	Description	Dimensions W (mm)
AP6000	N°1 depth adapter for Tmax T1-T2-T3 floor-standing	600
AP6001	N°1 depth adapter for Tmax T1-T2-T3 wall-mounting	600

Supports for duct

Code	Description
AD1009	N°4 plastic supports for horizontal duct
AD1037	N°4 metal supports for horizontal duct

Tmax XT Flanges for DIN-Rail mounting

Code	Description
AD3301	XT1 3P flange for DIN-Rail mounting
AD3302	XT1 4P flange for DIN-Rail mounting
AD3303	XT3 3P flange for DIN-Rail mounting
AD3304	XT3 4P flange for DIN-Rail mounting

Already supplied in the DIN-Rail mounting kit for breakers in MCCBs catalogue 1SDC210033D0901

ArTu M

Kit for apparatus

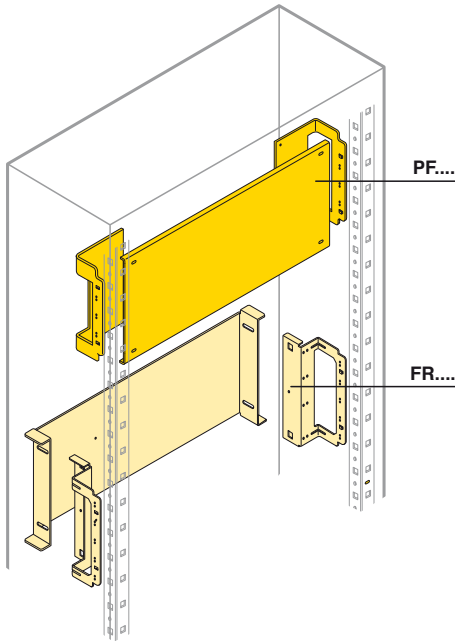

Blind back plates for and general apparatus

Code	Description	Dimensions H (mm)
24 DIN mod 36 DIN mod W=600mm W=800mm		
PF2610 ⁽¹⁾	PF2810 Blind back plate	200
PF4610	PF4810 Blind back plate	400
FR2601	FR2801 Recessed blind back plate	200
FR4601	FR4801 Recessed blind back plate	400

⁽¹⁾ Also for wall-mounted ArTu M. The panels must be ordered separately.

Blind, recessed and ventilated panels for and general apparatus

Code	Description	Dimensions H (mm)
24 DIN mod 36 DIN mod W=600mm W=800mm		
PC1600	PC1800 Blind panel	100
PC2600	PC2800 Blind panel	200
PC3600	PC3800 Blind panel	300
PC4600	PC4800 Blind panel	400
PC6600	PC6800 Blind panel	600
PC8600	PC8800 Blind panel	800
PC1660	PC1680 Blind panel (Inner door)	1600
PC1860	PC1880 Blind panel (Inner door)	1800
PC2060	PC2080 Blind panel (Inner door)	2000
PR2600	PR2800 Blind recessed panel	200
PR4600	PR4800 Blind recessed panel	400
PR6600	PR6800 Blind recessed panel	600
PA1600	Ventilated panel	100
PA2600	Ventilated panel	200

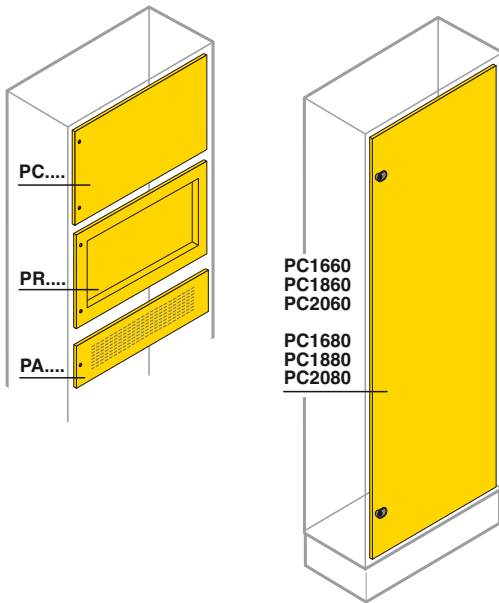

1STC802726F0001

PC1660
PC1860
PC2060

PC1680
PC1880
PC2080

ArTu M

Kit for apparatus

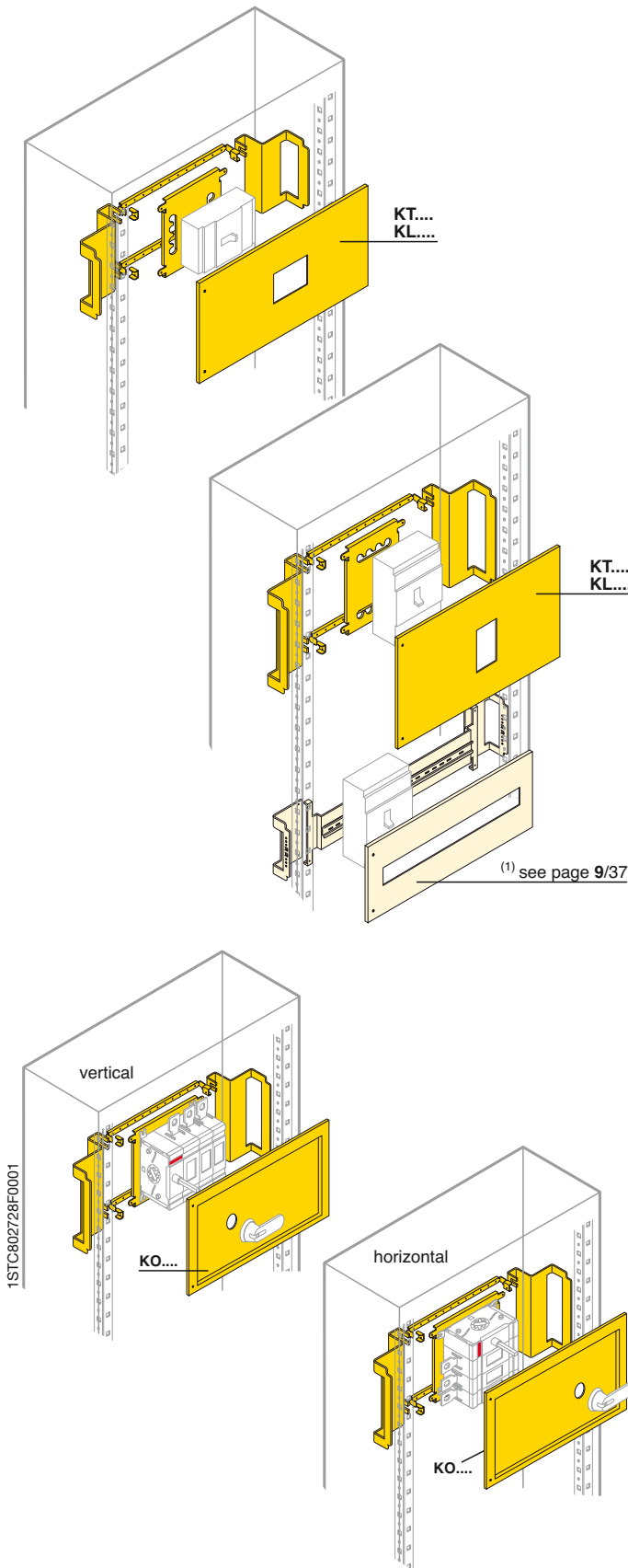

Kits for installing Tmax and Isomax circuit-breakers

Horizontal installation (front terminal)

Code	Description	Dimensions H (mm)
24 DIN mod 36 DIN mod W=600mm W=800mm		
KT1117	Kit for T1 3-4 poles fixed	200
KT1102	Kit for T1 4 poles fixed + RC mod.	200
KT2117	Kit for T2 3-4 poles fixed	200
KT2102	KL2103 Kit for T2 4 poles fixed + RC mod.	200
KT3112	KL3113 Kit for T3 3-4 poles fixed	200
KT3102	KL3103 Kit for T3 4 poles fixed + RC mod.	300
KT3118	Kit for T3 4 poles fixed + RC mod. wall-mounted ArTu M	200
KT4112	KL4115 Kit for T4 3-4 poles fixed	200
KT4110	KL4116 Kit for T4 4 poles fixed + RC mod.	200
KT5112	KL5114 Kit for T4 3-4 poles fixed	300
KT5110	KL5116 Kit for T5 4 poles fixed + RC mod.	300
KT6113	KL6113 Kit for T6 3-4 poles fixed	500
KX1617	Tmax XT1 3-4 poles fixed	200
KX1602	Tmax XT1 4 poles fixed + RC mod.	200
KX2619	Tmax XT2 3-4 poles fixed	200
KX2602	Tmax XT2 4 poles fixed + RC mod.	200
KX3612	KL3613 Tmax XT3 3-4 poles fixed	200
KX3618	Tmax XT3 3-4 poles fixed - Wall ArTu M	200
KX3602	KX3603 Tmax XT3 4 poles fixed + RC mod.	300
KX4612	KX4615 Tmax XT4 3-4 poles fixed	200
KX4610	Tmax XT4 4 poles fixed + RC mod.	200

Vertical installation (front terminal)

Code	Description	Dimensions H (mm)
24 DIN mod 36 DIN mod W=600mm W=800mm		
GD.... ⁽¹⁾	GD.... ⁽¹⁾ Kit on DIN rail for T1-T2-T3 3-4 poles fixed/RC	200÷600
KT3212	Kit for T3 3-4 poles fixed	300
KT4212	Kit for T4 3-4 poles fixed	400
KT4102	Kit for T4 4 poles fixed + RC mod.	500
KT5212	KL5212 Kit for T5 3-4 poles fixed	400
KT5102	KL5102 Kit for T5 4 poles fixed + RC mod.	500
KT6213	KL6213 Kit for T6 3-4 poles fixed	500
KX1618	Tmax XT1	200
KX1603	Tmax XT1 CB + diff. mod.	300
KX1604	Tmax XT1 N 3 CBs side by side	200
KX3614	Tmax XT3	300
KX3609	Tmax XT3 CB + diff. mod.	300
KX4614	Tmax XT4	300
KX4602	Tmax XT4 CB + diff. mod.	400

for 3 poles breakers please order accessory flange code AD3305 XT1 3P Flange for plate-mounting; AD3306 XT2 3P Flange for plate-mounting; AD3307 XT3 3P Flange for plate-mounting; AD3308 XT4 3P Flange for plate-mounting

For the Isomax kits see page 9/83.

Kit for OT

Code	Description	Dimensions H (mm)
24 DIN mod 36 DIN mod W=600mm W=800mm		
KO1201	Kit for OT200/250/315/400 - vertical installation	300
KO2260	KO2280 Kit for OT200/250/315/400 - horizontal installation	300
KO2261	KO2281 Kit for OT200/250/315/400 - vertical installation	300

ArTu M

Distribution system

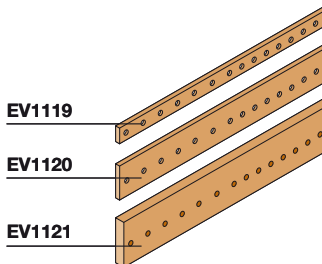
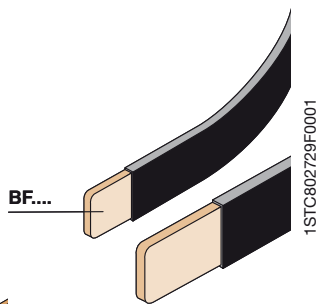
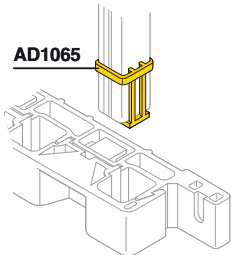
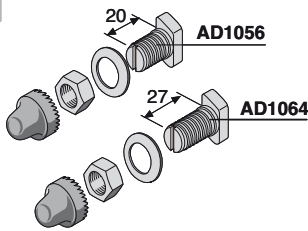
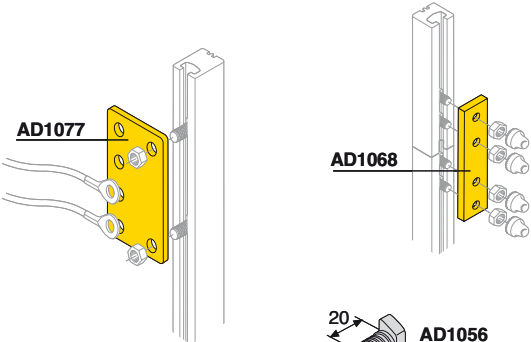
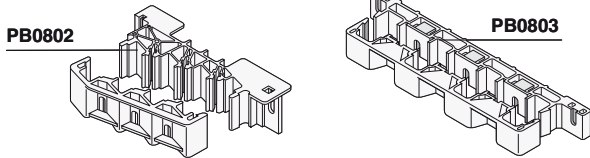
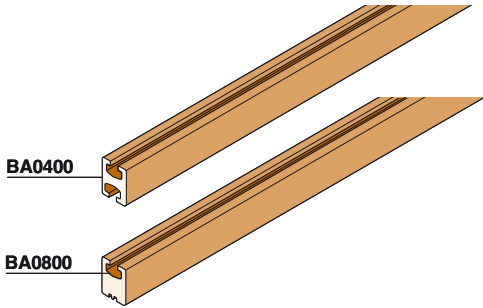

Distribution busbars with shaped section

Code	Description	Dimensions W (mm)
BA0400	Busbar In=400A	1730
BA0800	Busbar In=800A	1730

Busbar holders for busbars with shaped section

Code	Description
------	-------------

Scaled

PB0802	Scaled busbar holder In=800A - 35kA
--------	-------------------------------------

Linear

PB0803	Linear busbar holder In=800A - 35kA
--------	-------------------------------------

Joints for busbars with shaped section

Code	Description
------	-------------

AD1077	N°4 copper 400A branch joints
AD1068	N°4 joints for joining busbars with shaped section 400/800A

Hammer seal screws for busbars with shaped section

Code	Description
------	-------------

AD1056	N°12 M8 screws L=20mm for cable terminal
AD1064	N°12 M8 screws L=20mm for flat busbars up to 10mm, complete with screw-covering cap

Resting bases for busbars with shaped section

Code	Description
------	-------------

AD1065	N°4 resting bases for 400/800A busbars
--------	--

Flexible busbars

Flexible busbars insulated in self-extinguishing material

Code	Description	In (A)	Dimensions W (mm)
------	-------------	--------	----------------------

BF1602	N°2 flexible busbars, section 20x3	250	2000
BF2502	N°2 flexible busbars, section 20x5	400	2000
BF4002	N°2 flexible busbars, section 24x6	500	2000
BF4012 ⁽¹⁾	N°2 flexible busbars, section 32x5	630	2000

⁽¹⁾ Only for circuit-breakers with front extended terminals or rear terminals

Earthing busbars

Copper busbars drilled and threaded for rapid connection of the conductors.

Code	Description	Dimensions W (mm)
------	-------------	----------------------

EV1119	N°2 earthing busbars 20x5 threaded M6	2000
EV1120	N°2 earthing busbars 25x5 threaded M6	2000
EV1121	N°2 earthing busbars 50x5 threaded M6	2000

Insulators and copper busbars for neutral/earthing

Code	Description
------	-------------

EV1122	N°50 hexagonal insulators 30x30mm M6
EV1123	N°50 hexagonal insulators 30x30mm M8
EV1124	N°25 hexagonal insulators 36x50mm M6
EV1125	N°25 hexagonal insulators 36x50mm M8

ArTu M

Distribution system

Pic.1

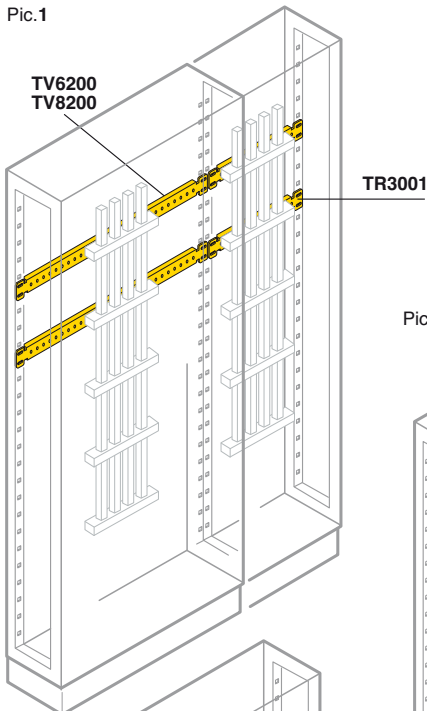

Pic.2

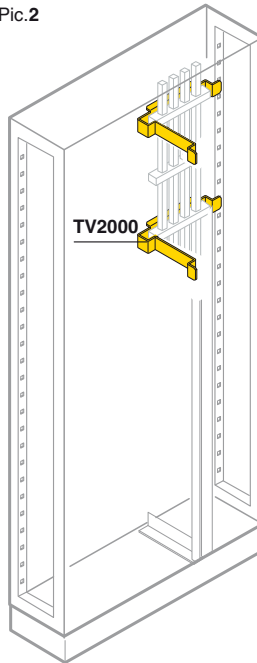

Pic.3

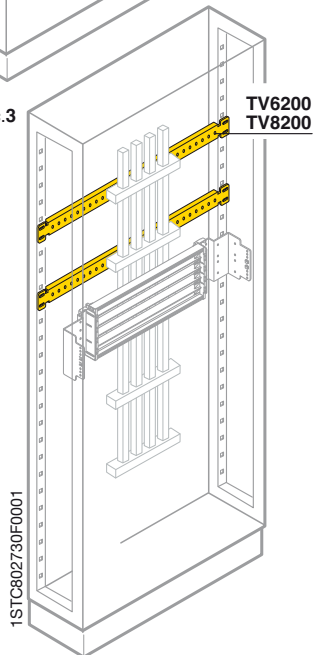

Crosspieces for flat busbars 400/800A

Busbars vertically on back of structure

Code	Mounting Pic.	Description
TV6200	1	N°2 crosspieces structure W=600mm with PB0803
TV8200	1	N°2 crosspieces structure W=800mm with PB0803

Busbars vertically on back of structure of external cable container

Code	Mounting Pic.	Description
TR3001	1	N°2 crosspieces back of cable container W=300mm with PB0802

Busbars vertically in internal cable container

Code	Mounting Pic.	Description
TV2000	2	N°2 internal cable container crosspieces W=200mm with PB0802

Connection to Unifix H system

Code	Mounting Pic.	Description
TV6200	3	N°2 structure crosspieces W=600mm with PB0803
TV8200	3	N°2 structure crosspieces W=800mm with PB0803

ArTu M

Distribution system

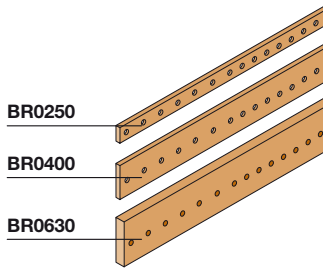

Flat busbar

Copper busbars 1750mm in length drilled. Can be used both with linear BP0630 and scaled BP0634 busbar holders.

Code	Description	In (A)	Dimensions W (mm)
BR0250	N°2 copper busbars 15x5	250	1750
BR0400	N°2 copper busbars 25x5	400	1750
BR0630	N°2 copper busbars 30x10	630	1750

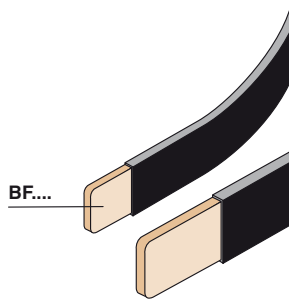

Busbar holders

Busbar holders in insulating self-extinguishing material, certified in conformity with the EN 60439-1 Standard for an $I_{cc} \leq 35kA$

Code	Description
BP0630	N°2 linear busbar holders In=630A - 32kA
BP0632	N°2 terminal covers for linear busbar holders BP0630

Flexible busbars

Flexible busbars insulated in self-extinguishing material

Code	Description	In (A)	Dimensions W (mm)
BF1602	N°2 flexible busbars, section 20x3	250	2000
BF2502	N°2 flexible busbars, section 20x5	400	2000
BF4002	N°2 flexible busbars, section 24x6	500	2000
BF4012 ⁽¹⁾	N°2 flexible busbars, section 32x5	630	2000

⁽¹⁾ Only for circuit-breakers with front extended terminals or rear terminals.

Crosspieces for flat busbars

Crosspieces for fixing the busbar holders to the structure with various installation possibilities

Busbar vertically on back of structure or of cable container

Code	Mounting Pic.	Description
TV6200	1	N°2 crosspieces back of structure W=600mm with BP4466
TV8200	1	N°2 crosspieces back of structure W=800mm with BP4466
TR3001	2	N°2 crosspieces back of cable container W=300mm with BP4466 or scaled BP4477

Earthing busbars

Copper busbars drilled and threaded for rapid connection of the conductors.

Code	Description	Dimensions W (mm)
EV1119	N°2 earthing busbars 20x5 threaded M6	2000
EV1120	N°2 earthing busbars 25x5 threaded M6	2000
EV1121	N°2 earthing busbars 50x5 threaded M6	2000

Insulators and copper busbars for neutral/earthing

Code	Description
EV1122	N°50 hexagonal insulators 30x30mm M6
EV1123	N°50 hexagonal insulators 30x30mm M8
EV1124	N°25 hexagonal insulators 36x50mm M6
EV1125	N°25 hexagonal insulators 36x50mm M8

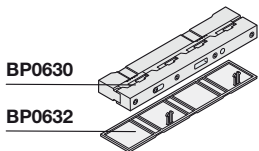

Pic.1

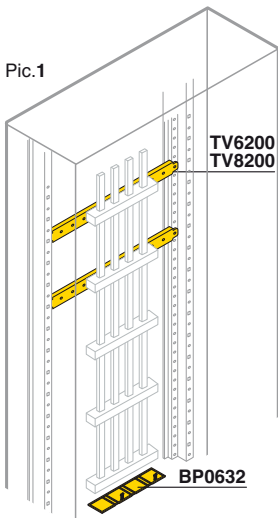

Pic.2

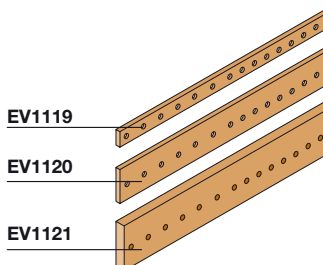
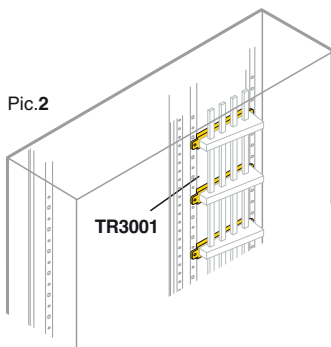

EV1122
EV1123
EV1124
EV1125

ArTu M

Distribution system

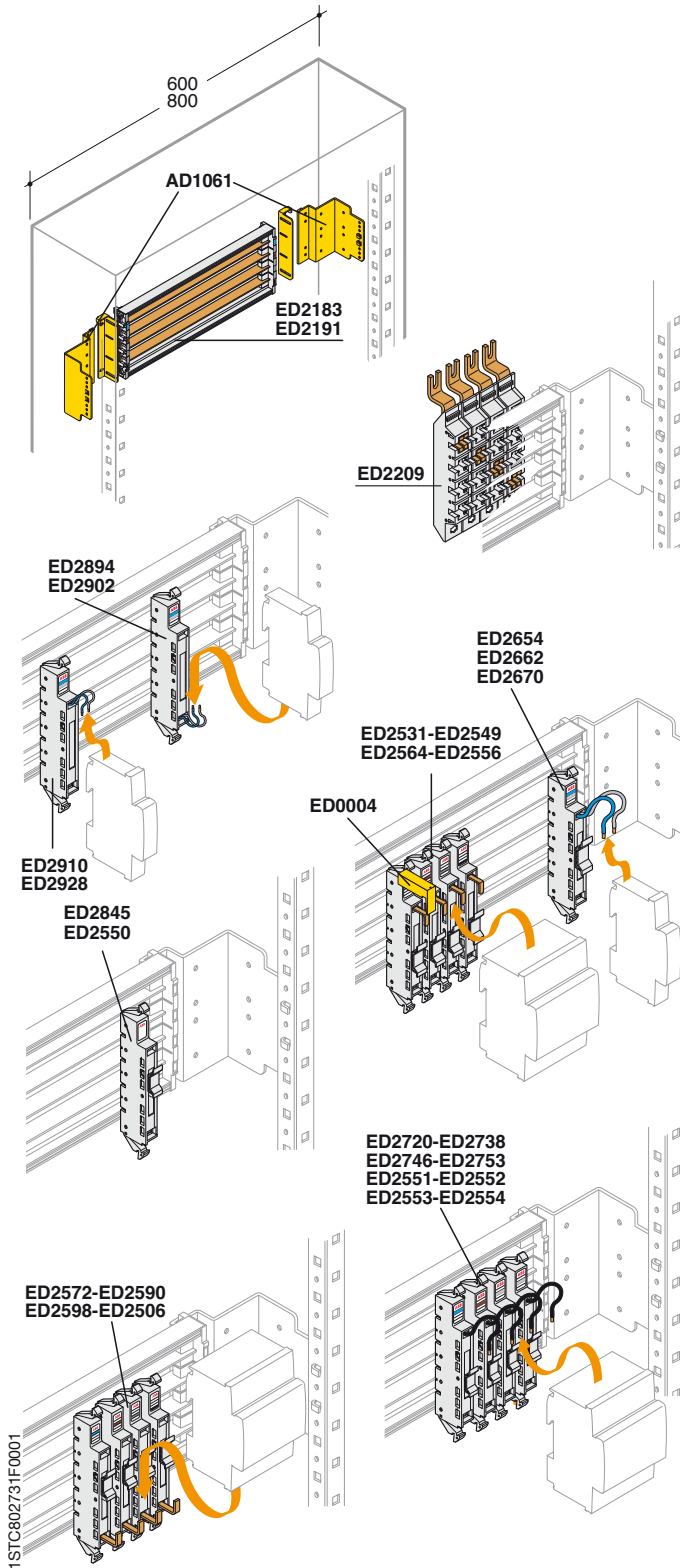

Unifix H

Frames for Tmax

Code	Description	Dimensions W (mm)
ED2183	Frame with 24 DIN module busbar	600
ED2191	Frame with 36 DIN module busbar	800
AD1061	N°2 fixing brackets onto structure for ED2183 o ED2091	

Feeder modules

Code	Description
ED2209	4P 400A feeder module (for ED2183-ED2191)

Basic modules I_n 16A

Code	Description
ED2894	Basic module for DIN L1-N top 16A
ED2902	Basic module for DIN L1-L2 top 16A
ED2910	Basic module for DIN L1-N bottom 16A
ED2928	Basic module for DIN L1-L2 bottom 16A

Basic modules I_n 40A

Code	Description
ED2654	Basic module L1/Neutral top 40A
ED2662	Basic module L2/Neutral top 40A
ED2670	Basic module L3/Neutral top 40A

Basic modules I_n 63A

Code	Description
ED2531	Basic module L1 top 63A
ED2549	Basic module L2 top 63A
ED2556	Basic module L3 top 63A
ED2564	Basic module Neutral top 63A
ED2572	Basic module L1 bottom 63A
ED2590	Basic module L2 bottom 63A
ED2598	Basic module L3 bottom 63A
ED2606	Basic module Neutral bottom 63A

Basic modules I_n 100A

Code	Description
ED2720	Basic module with cable L1 top 100A
ED2738	Basic module with cable L2 top 100A
ED2746	Basic module with cable L3 top 100A
ED2753	Basic module with cable Neutral top 100A

Basic modules ≤I_n 40A S800

Code	Description
ED2557	Basic module L1 top ≤40A
ED2558	Basic module L2 top ≤40A
ED2559	Basic module L3 top ≤40A
ED2560	Basic module Neutral top ≤40A

Basic modules I_n 125A S800

Code	Description
ED2551	Basic module L1 top 125A
ED2552	Basic module L2 top 125A
ED2553	Basic module L3 top 125A
ED2554	Basic module Neutral bottom 125A
ED2550	Basic module false pole W=27mm

ArTu M

Distribution system

ED2217-ED2225
ED2233-ED2241
ED2258-ED2266
ED2274-ED2282
ED2332-ED2340
ED2357-ED2365

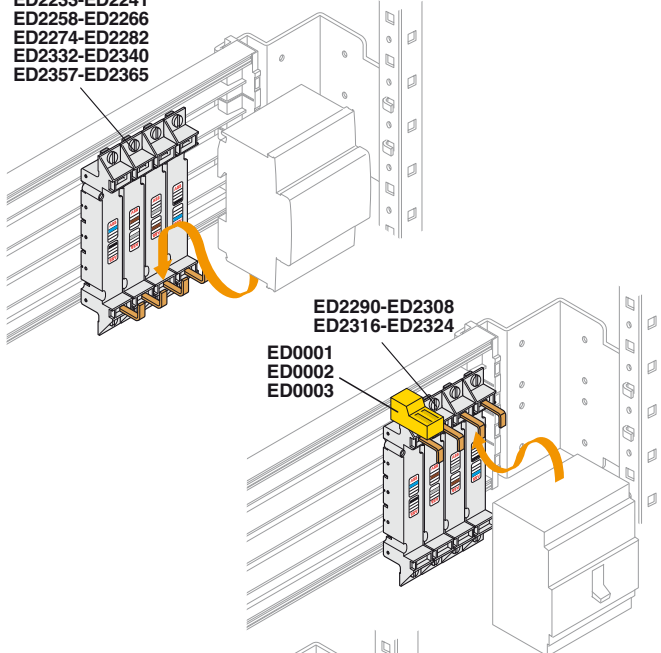

ED2290-ED2308
ED2316-ED2324
ED0001
ED0002
ED0003

ED2381
ED2399

ED2373

ED2407

PM3624
PM3836

ED2936

1STC802732F0001

Unifix H

Moduli base I_n 160A Tmax T1

Codice	Descrizione
ED2217	Basic module L1 top L2 bottom
ED2225	Basic module L2 top L1 bottom
ED2233	Basic module L3 top N bottom
ED2241	Basic module N top L3 bottom
ED2373	Basic module false pole for residual current release RC221
ED2381	Basic module false pole for solenoid operator

Basic modules I_n 160A Tmax T2

Code	Description
ED2258	Basic module L1 top L2 bottom
ED2266	Basic module L2 top L1 bottom
ED2274	Basic module L3 top N bottom
ED2282	Basic module N top L3 bottom
ED2373	Basic module false pole for residual current release RC221
ED2399	Basic module false pole for solenoid operator

Basic modules I_n 250A Tmax T3

Code	Description
ED2290	Basic module L1 top
ED2308	Basic module L2 top
ED2316	Basic module L3 top
ED2324	Basic module N top
ED2332	Basic module L1 bottom
ED2340	Basic module L2 bottom
ED2357	Basic module L3 bottom
ED2365	Basic module N bottom
ED2373	Basic module false pole for residual current release RC221

Accessories

Code	Description
ED2845	Basic module false pole for DDA
ED2852	Basic module false pole for modular MDRC
ED2407	N°2 IP20 covers (for ED2183-ED2191) W=173mm (10 DIN modules)
ED2936	N°6 duct supports 40x60mm (only for modular apparatus)
AD1061	ArTu M Kit for ED2183 and ED2191
PM3624	Modular front panel 300x600mm (HxW)
PM3836	Modular front panel 300x800mm (HxW)

Spare parts

Code	Description
ED0001	N°10 terminal covers T1
ED0002	N°10 terminal covers T2
ED0003	N°10 terminal covers T3
ED0004	N°10 terminal covers S200/F200

ArTu M

Distribution system

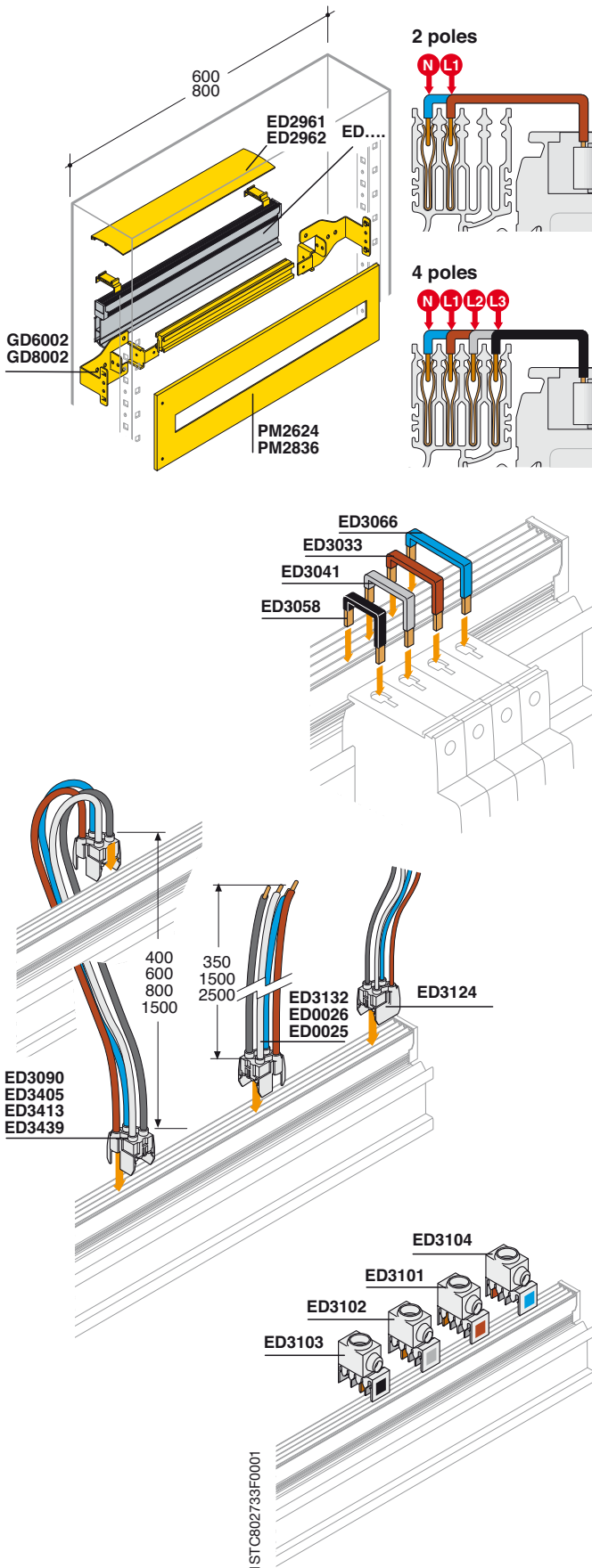

Unifix L

2-poles busbars

Code	Description	Dimensions W (mm)
ED2985	100A 2P 8 module busbar	200
ED2993	100A 2P 12 module busbar	400
ED3009	100A 2P 18 module busbar	450
ED3017	100A 2P 24 module busbar	600
ED3025	100A 2P 36 module busbar	800

4-poles busbars

Code	Description	Dimensions W (mm)
ED2944	100A 4P 12 module busbar	400
ED2951	100A 4P 18 module busbar	450
ED2969	100A 4P 24 module busbar	600
ED2977	100A 4P 36 module busbar	800

Connections for various apparatus

Code	Description
ED3108	Connection with 2 conductors L/N 16A
ED3116	Connection with 3 conductors L1/L2/L3 16A
ED3124	Connection with 4 conductors L1/L2/L3/N 16A single phase
ED3355	Connection with 2 conductors L1/N 40A
ED3363	Connection with 3 conductors L1/L2/L3 40A
ED3371	Connection with 4 conductors L1/L2/L3/N 40A

Connections for apparatus

Code	Description
ED3272	N°10 connections L1-N 40 A
ED3280	N°10 connections L2-N 40 A
ED3298	N°10 connections L3-N 40 A
ED3033	N°10 connections L 1 100A
ED3041	N°10 connections L 2 100A
ED3058	N°10 connections L 3 100A
ED3066	N°10 connections N 100A
ED3132	Feeder with 4P 100A cable (W=350mm)
ED0026	Feeder with 4P 100A cable (W=1500mm)
ED0025	Feeder with 4P 100A cable (W=2500mm)

Power supply modules with cable

Code	Description	Dimensions W (mm)
ED3082	Parallel module 2P 100A with cable	600
ED3405	Parallel module 4P 100A with cable	400
ED3090	Parallel module 4P 100A with cable	600
ED3413	Parallel module 4P 100A with cable	800
ED3439	Parallel module 4P 100A with cable	1500

Power supply modules without cable In 100A

Code	Description
ED3101	N°10 single-pole power supply terminals L1
ED3102	N°10 single-pole power supply terminals L2
ED3103	N°10 single-pole power supply terminals L3
ED3104	N°10 single-pole power supply terminals N

Accessories

Code	Description	Dimensions W (mm)
ED2961	N°10 busbar covers	600
ED2962	N°2 busbar covers	800
GD6002	DIN rail Kit and supports	600
GD8002	DIN rail Kit and supports	800
PM2624	Modular front panel 200x600mm (HxW)	
PM2836	Modular front panel 200x800mm (HxW)	

ArTu M

Accessories

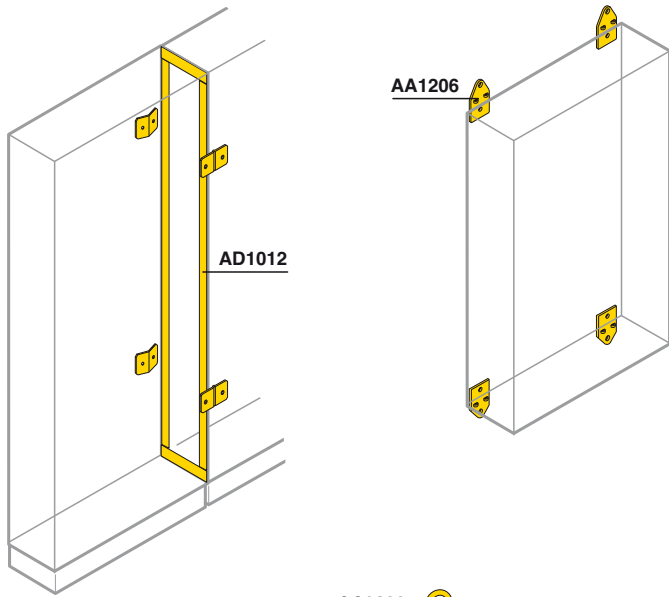

Kits for placing structures side by side

The ArTu M switchgear can be placed side by side laterally. The IP65 side-by-side kit consists of a set of supports and a gasket for keeping the degree of protection. In the IP31 version, in addition to kit AD1012, order the double finishing section (see table on page 9/25).

Code	Description
AD1012	Kit for laterally placing structures side by side H=1400-1600-1800-2000mm

Brackets for wall fixing

These allow ArTu M switchgear to be fixed to the wall.

Code	Description
AA1206	N° 4 wall fixing brackets

Lifting eyebolts

These allow cabled switchgear to be lifted. They are made of steel treated with white passivated galvanisation.

Code	Description
AA9600	N° 2 steel M12 lifting eyebolts

Lifting reinforcements

Allow several pieces of ArTu M switchgear to be handled side by side.

Code	Description
SA1350	N°2 lifting reinforcements for side-by-side structures

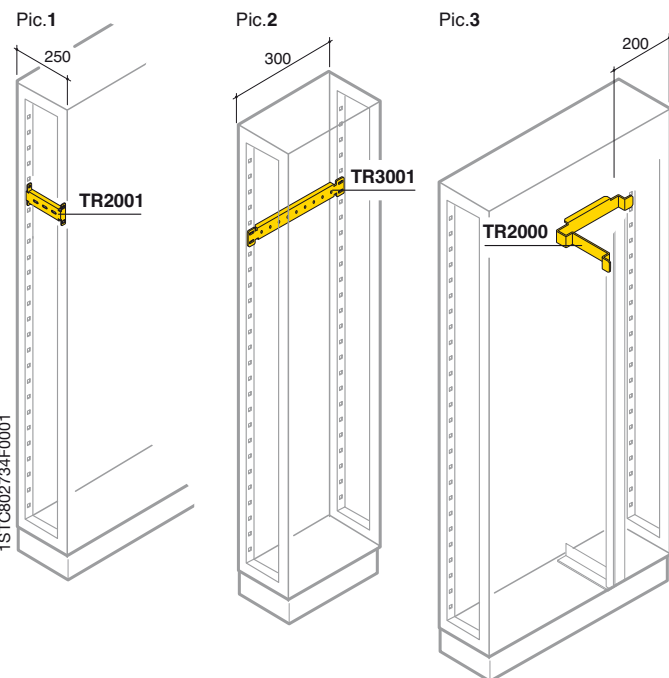
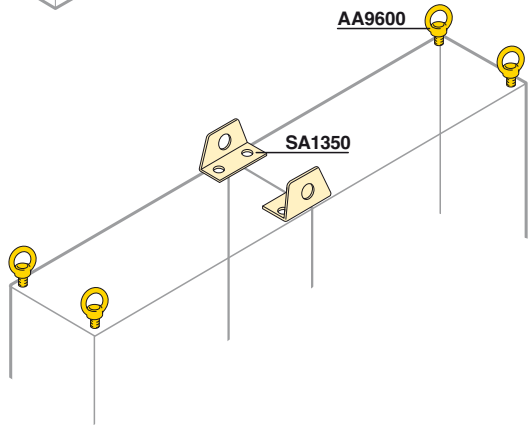

Crosspieces for accessories

Can be mounted on the structure to anchor the cables or to mount accessories. The crosspieces for accessories can be mounted on the side, on the rear or in the cable container of the structure.

Code	Mounting Pic.	Description
TR2001	1	N° 2 Structure lateral crosspieces D=250mm
TR3001	2	N° 2 External cable container rear crosspieces W=300mm
TV2000	3	N° 2 Internal cable container crosspieces W=200mm

ArTu M

Accessories

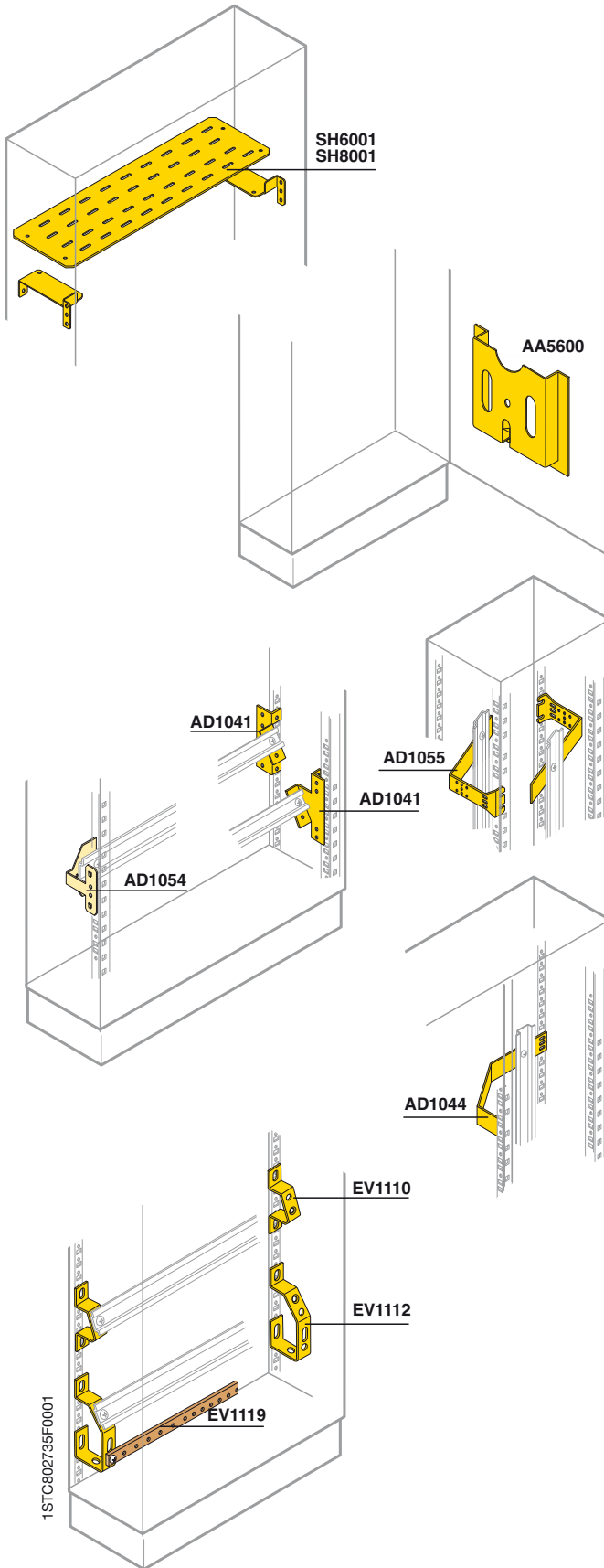

Horizontal shelf

Non-supporting horizontal shelf which allows separations to be made inside floor-mounted ArTu M switchgear.
In structure with W=800 with internal cable container, use SH6001.

Code	Description	Dimensions P (mm)
24 DIN mod	36 DIN mod	
W=600mm	W=800mm	
SH6001	SH8001 Horizontal shelf for structure	195

Diagram pocket

The diagram pocket (made of plastic RAL 2004 colour, dim. HxW 237x265mm type A4) is applied inside the blind doors/panels of suitable dimensions, using the adhesive provided.

Code	Description
AA5600	Plastic diagram pocket

Supports for terminal boxes

Structure

Code	Description
AD1041	N° 2 supports for horizontal 45° angled terminal box
AD1054	N° 2 supports for horizontal terminal box

Internal cable container

Code	Description
AD1044	N° 4 supports for vertical terminal box

Additional cable container

Code	Description
AD1055	N° 4 supports for vertical terminal box in internal/additional cable container

Angled supports for terminal boxes and earthing busbars

Code	Description
EV1110	N°50 angled supports 1 row of terminals
EV2110	N°10 angled supports 1 row of terminals
EV1112	N°50 angled supports 1 row of terminals + earth
EV2112	N°10 angled supports 1 row of terminals + earth
EV1113	N°2 angled supports 1 row of terminals + earth

ArTu M

Accessories

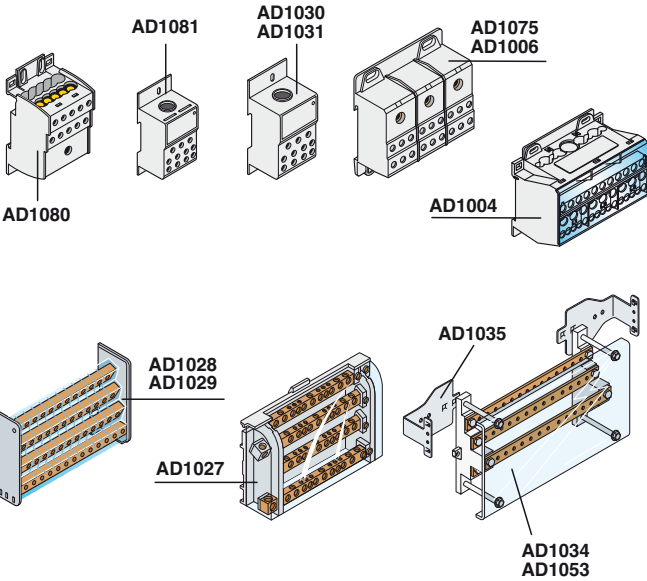
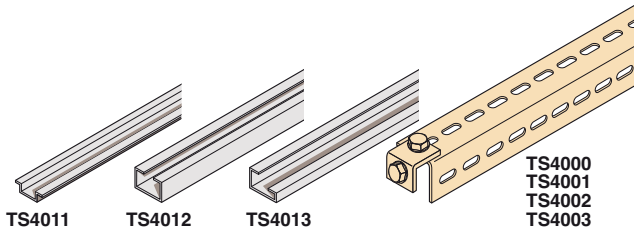

Sections for accessories

Code	Description	Dimensions W (mm)
TS4011	N°2 sections EN50024 C30	2000
TS4012	N°2 sections EN50035 G32	2000
TS4013	N°2 DIN sections EN50022	2000
TS4000	N°2 cable rails	600
TS4001	N°2 cable rails	800
TS4002	N°2 cable rails	1000
TS4003	N°2 cable rails	1200

Dividers

Code	Description		
Single-pole	Three-pole	Four-pole	
AD1076 ⁽¹⁾	AD1075	AD1004	Modular 125A
AD1080 ⁽²⁾		AD1028	Modular 125A-medium-89x93x48 (LxWxH)
		AD1029	Modular 125A-large-126x93x48 (LxWxH)
AD1007 ⁽¹⁾	AD1006	AD1027	Modular 160A
AD1081 ⁽²⁾			Modular 250A
AD1030		AD1034	Horizontal 250A for structures W=600mm
		AD1053	Horizontal 250A for structures W=800mm
AD1031			Modular 400A

⁽¹⁾ 10 outputs
⁽²⁾ 6 outputs

Amounting accessories

Code	Description
AD1038	Supports for fixing to the structure for AD1034 and AD1053
AD1083	Connection accessory between two AD1080

1STC802736F0001

ArTu M

9

ArTu M

Accessories

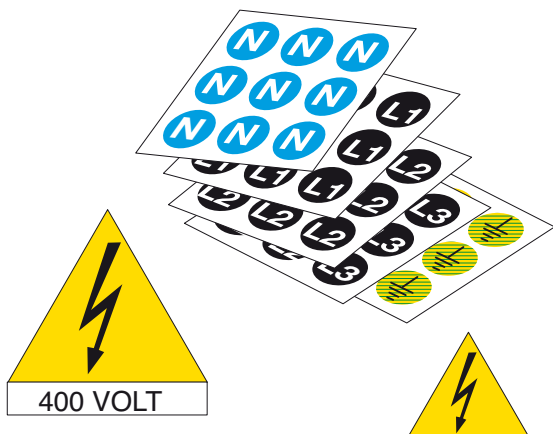

Marking

Code	Description
EV1150	N°490 adhesive labels ø12mm symbol N
EV1151	N°490 adhesive labels ø12mm symbol L1
EV1152	N°490 adhesive labels ø12mm symbol L2
EV1153	N°490 adhesive labels ø12mm symbol L3
EV1154	N°490 adhesive labels ø12mm symbol T
EV1155	N°10 triangular adhesive labels 125mm with 400V lightning arrow symbol
EV1156	N°100 triangular adhesive labels 50mm with lightning arrow symbol

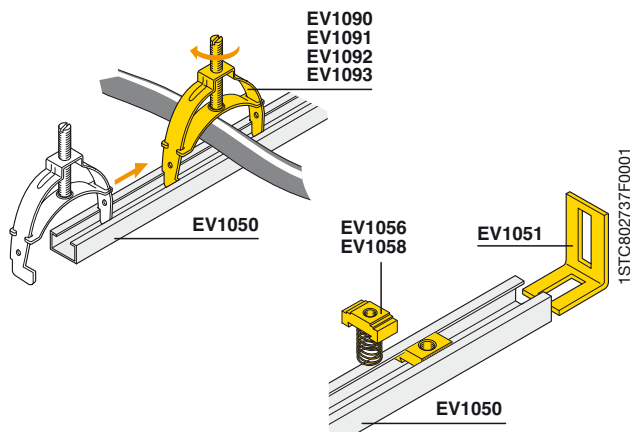

Brackets for anchoring cables

Adjustable cable blocking bracket can be mounted on sections with 10mm slot EV1050.

Code	Description
EV1090	N°10 cable blocking brackets min= max ø 9÷16mm
EV1091	N°10 cable blocking brackets min= max ø 16÷30mm
EV1092	N°5 cable blocking brackets min= max ø 30÷48mm
EV1093	N°5 cable blocking brackets min= max ø 48÷72mm

Aluminium sliding guides for universal uses

Code	Description
EV1050	N°10 aluminium supporting sections 30x15 - W=2000mm
EV1051	N°25 fixing brackets for EV1050
EV1056	N°100 aluminium M6 nuts for EV1050
EV1058	N°100 aluminium M8 nuts for EV1050

ArTu M

Accessories

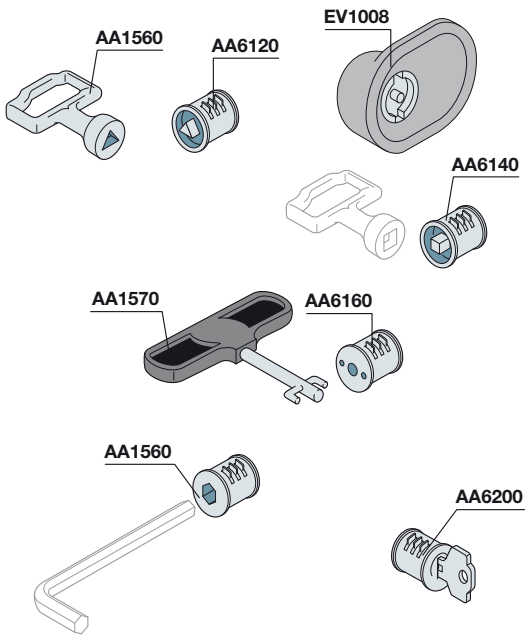

Inserts and keys

Code	Description
Wall-mounted structures and cable container	
AA8005	Box + E739 Ronis insert + key, without tab
EV1008	Box + Yale insert (without tab)
EV1036	Insert + Yale key for EV1008
EV1037	Ronis 455 insert + key for EV1008
EV1039	3mm double-tab insert + key for EV1008
Floor-mounted structures	
AA6100	Double-tab insert
AD1058	Double-tab Zn+Al+Mg alloy key
AA6200	Yale insert + key
AA6120	Male 6.4 triangular insert on ø 7.6
AA1560	Triangular key
AA6140	Male 7square type insert; key not available
AA6180	Hexagonal 8 type insert embedded; key not available
AA6160	FIST type insert (FIAT)
AA1570	Fiat key
AA8004	Ronis E739 insert + key

Accessories

Code	Description
AD1036	N°20 cage nuts
VB7035	RAL 7035 colour spray paint for touching up (400 ml spray can)

Spare parts

Code	Description
AD1090	N°10 hinges + screws for panels (spare part ACP468)
AD1091	N°10 plug + door key kits (spare part APT002)
CA1401	Chimes for door H=1400mm (spare part)
CA1600	Chimes for door H=1600mm (spare part)
CA1800	Chimes for door H=1800mm (spare part)
CA2000	Chimes for door H=2000mm (spare part)
AD1033	N°50 three-lobed M6 spare screws
VB7035	RAL 7035 colour spray paint for touching up (400 ml spray can)
AD1057	"ArTu Survival Kit" - Accessories and small items for spare parts
PV4060	Glass door for switchgear for operating theatres
PO6069	Blind door for switchgear for operating theatres
AD1022	ArTu handle complete with lock and cover
AD1070	N°10 ArTu handle covers
AZ4000	N°4 base strip angle pieces H=100mm
ZD2625	Base strip consisting of 4 angle pieces and 4 flanges
ZD2825	Base strip consisting of 4 angle pieces and 4 flanges
ZD2325	Base strip consisting of 4 angle pieces and 4 flanges

To construct a base strip 200mm high, order a H=100mm kit, which includes four additional angle pieces and four additional flanges.

1STC802738F0001

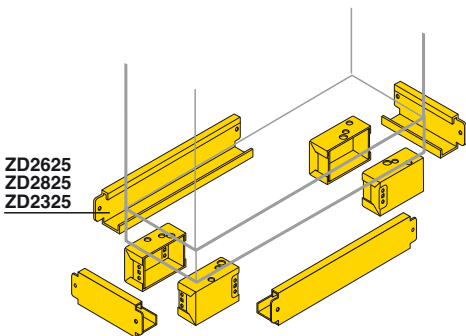

ArTu K (without segregation/segregated) Structure

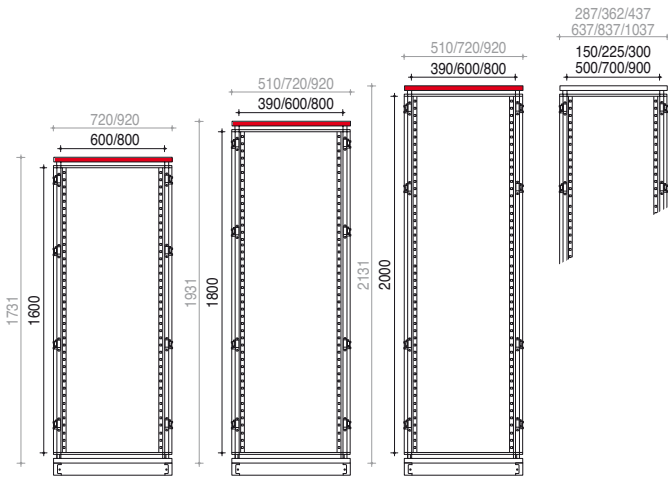

Base-Top-Base strip

Preassembled structure complete with cable input flange, base strip angle pieces and front flanges – the lateral ones must be ordered separately.

Code	Description	Useful dimensions D (mm)		
12 DIN mod	24 DIN mod	36 DIN mod		
W=390mm	W=600mm	W=800mm		
SK6025	SK8025	Base-Top-Base strip	150	
SK4040	SK6040	SK8040	Base-Top-Base strip	225
SK4050	SK6050	SK8050	Base-Top-Base strip	300
SK4060	SK6060	SK8060	Base-Top-Base strip	500
SK4080	SK6080	SK8080	Base-Top-Base strip	700
SK4010	SK6010	SK8010	Base-Top-Base strip	900

Uprights

Code	Description	Useful dimensions H (mm)
SK1600	N° 4 uprights	1600
SK1800	N° 4 uprights	1800
SK2000	N° 4 uprights	2000

Base strip lateral flanges

Code	Description	Useful dimensions H (mm)
ZD1015	N°2 base strip lateral flanges	150
ZD1025	N°2 base strip lateral flanges	225
ZD1030	N°2 base strip lateral flanges	300
ZD1050	N°2 base strip lateral flanges	500
ZD1070	N°2 base strip lateral flanges	700
ZD1090	N°2 base strip lateral flanges	900

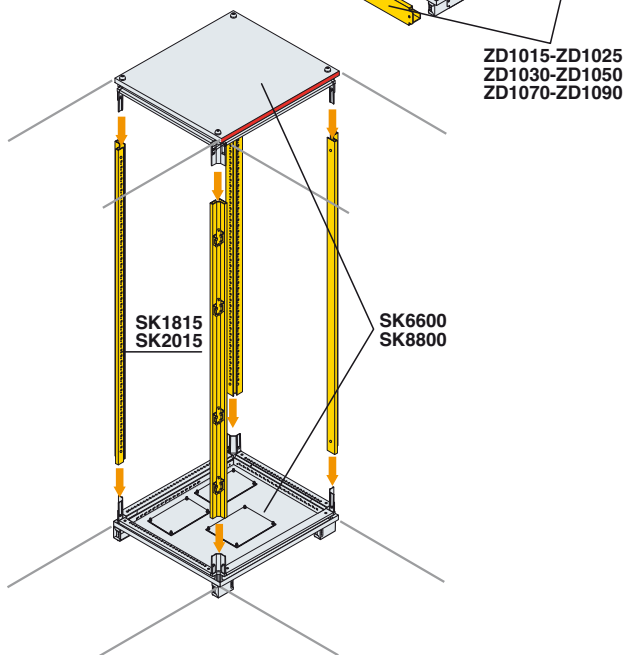
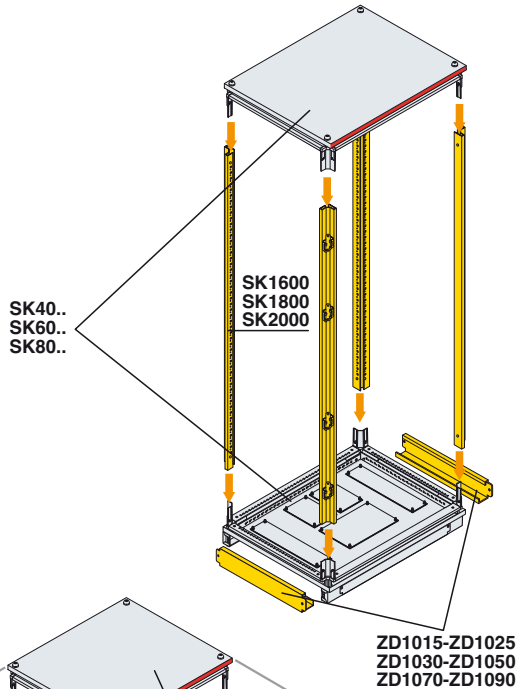

Base-Top-Base strip for corner switchgear

Code	Description	Useful dimensions WxD (mm)
SK6600	Corner base-Top-Base strip	500x500
SK8800	Corner base-Top-Base strip	700x700

Uprights for corner switchgear

Code	Description	Useful dimensions H (mm)
SK1815	N° 4 corner uprights	1800
SK2015	N° 4 corner uprights	2000

1STC802739F0001

ArTu K (without segregation/segregated) Structure

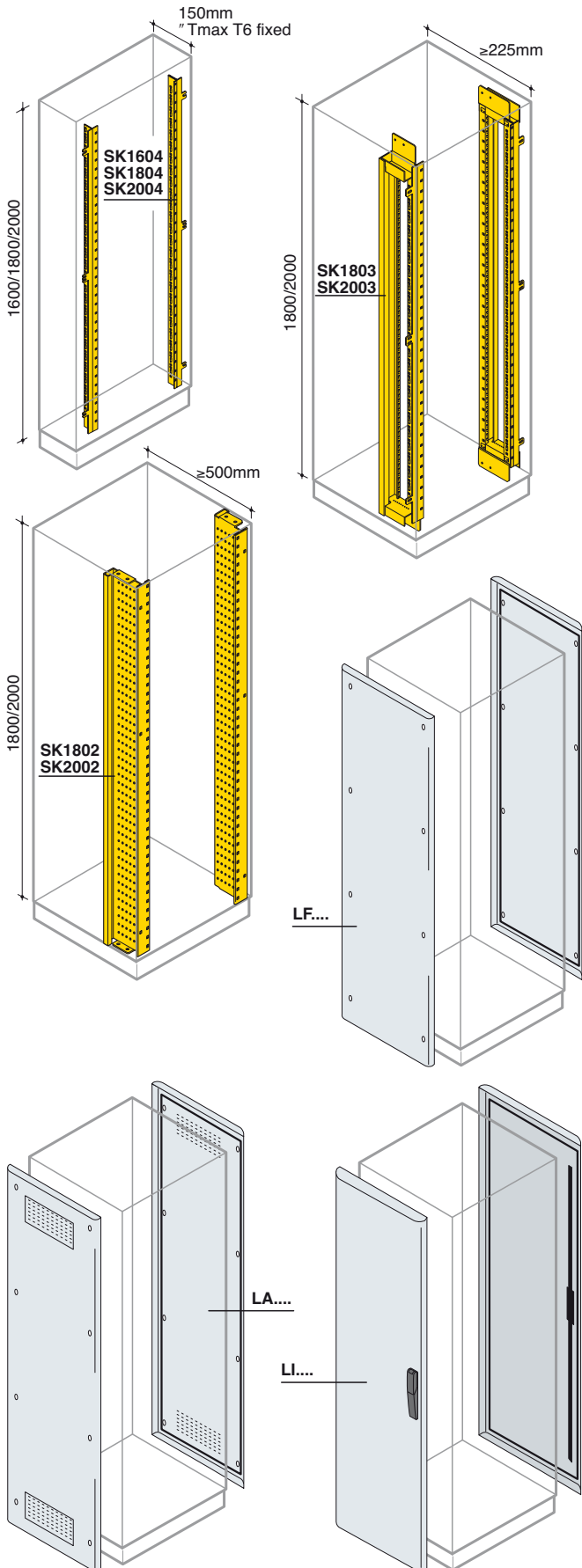

Functional frames for switchgear without segregation (open frame)

Allow the circuit-breaker door kit to be mounted in the combinations shown in the table

Code	Description	Dimensions H (mm)
Reduced frame	Standard frame	
SK1604	N°2 functional frames	1600
SK1804	SK1803 N°2 functional frames	1800
SK2004	SK2003 N°2 functional frames	2000

To make structures with internal cable container (switchgear W=800mm) the functional frame is already included in the internal cable container kit (see page 9/55).

		Type of frame	Horiz busbars	Switchgear depth [mm]						Maximum circuit-breaker installable
				150	225	300	500	700	900	
Moulded-case circuit-breakers	Fixed	Reduced	no	≤T6	≤T6					
			yes			≤T6	≤T6	≤T6	≤T6	
		Standard	no		≤T6	≤T7				
	yes					≤T7	≤T7	≤T7	≤T7	
	yes					≤T7	≤T7	≤T7	≤T7	
	Air circuit-breakers	Fixed	Standard	no		X1				
yes						X1	X1	X1	X1	
Fixed/withdr.		Standard	yes				≤E3	≤E4		

Functional frames for segregated switchgear (closed frame)

Code	Description	Dimensions H (mm)
Segregated frame		
D≥500mm		
SK1802	N°2 segregated functional frames	1800
SK2002	N°2 segregated functional frames	2000

To make structures with internal cable container (switchgear W=800mm), the functional frame is already included in the kit for internal cable container (see page 9/55).

IP65 Side panels

Code	Description	Dimensions D (mm)	
H=1600mm	H=1800mm	H=2000mm	
LF1626	LF1826 LF2026	N°2 side panels IP65	150
	LF1840 LF2040	N°2 side panels IP65	225
	LF1850 LF2050	N°2 side panels IP65	300
	LF1860 LF2060	N°2 side panels IP65	500
	LF1880 LF2080	N°2 side panels IP65	700
	LF1810 LF2010	N°2 side panels IP65	900

IP41 Ventilated side panels

Code	Aeration surface entry side (valid for 1 panel)	Description	Dimensions D (mm)	
H=1800mm	H=2000mm	cm ²		
LA1860	LA2060	75	N°2 ventilated side panels IP41	500
LA1880	LA2080	113	N°2 ventilated side panels IP41	700
LA1810	LA2010	170	N°2 ventilated side panels IP41	900

IP65 Blind side doors

Code	Description	Dimensions D (mm)	
H=1800mm	H=2000mm		
LI1840	LI2040	N°2 side doors IP65	225
LI1860	LI2060	N°2 side doors IP65	500
LI1880	LI2080	N°2 side doors IP65	700

ArTu K (without segregation/segregated)

Structure

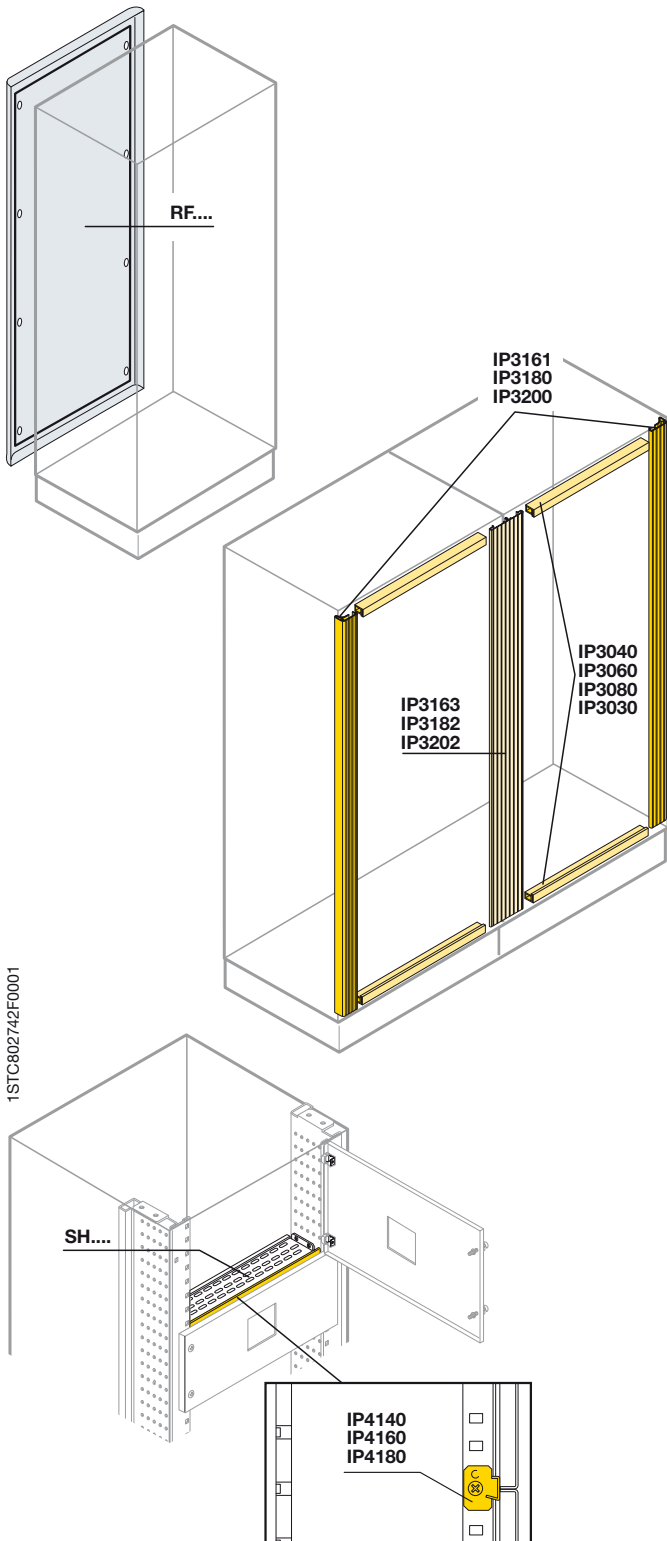

IP65 Rear panels

Code	Description	Dimensions H (mm)		
12 DIN mod W=390mm	24 DIN mod W=600mm	36 DIN mod W=800mm		
RF1660	RF1680	Rear panel IP65	1600	
RF1840	RF1860	RF1880	Rear panel IP65	1800
RF2040	RF2060	RF2080	Rear panel IP65	2000

IP 31 Finishing section

For IP31 version switchgear (without door), use the special finishing kits already sized for the standard heights and widths of ArTu switchgear. In the case of switchgear placed side by side, use the special double IP31 kit on the joining uprights.

Horizontal section

Code	Description			
12 DIN mod W=390mm	24 DIN mod W=600mm	36 DIN mod W=800mm	Addit. cable cont. W=300mm	
IP3040	IP3060	IP3080	IP3030	N°2 IP31 horizontal finishing sections

Vertical section

Code	Description	Dimensions H (mm)
IP3161	N°2 IP31 horizontal finishing sections	1600
IP3180	N°2 IP31 horizontal finishing sections	1800
IP3200	N°2 IP31 horizontal finishing sections	2000
IP3163	Double vertical finishing profile IP31 for side-by-side switchgear	1600
IP3182	Double vertical finishing profile IP31 for side-by-side switchgear	1800
IP3202	Double vertical finishing profile IP31 for side-by-side switchgear	2000

IP41 Kits

Not segregated structures

Code	Description		
12 DIN mod W=390mm	24 DIN mod W=600mm	36 DIN mod W=800mm	
IP4140	IP4160	IP4180	N°4 IP41 horizontal kits for segregated structures

Segregated structures ⁽¹⁾

Code	Description		
12 DIN mod W=390mm	24 DIN mod W=600mm	36 DIN mod W=800mm	
IP4141	IP4161	IP4181	N°4 IP41 horizontal kits for segregated structures

⁽¹⁾ To complete with universal segregation SH 4000, SH 6000, SH 8000 (see page 9/68).

ArTu K (without segregation/segregated) Structure

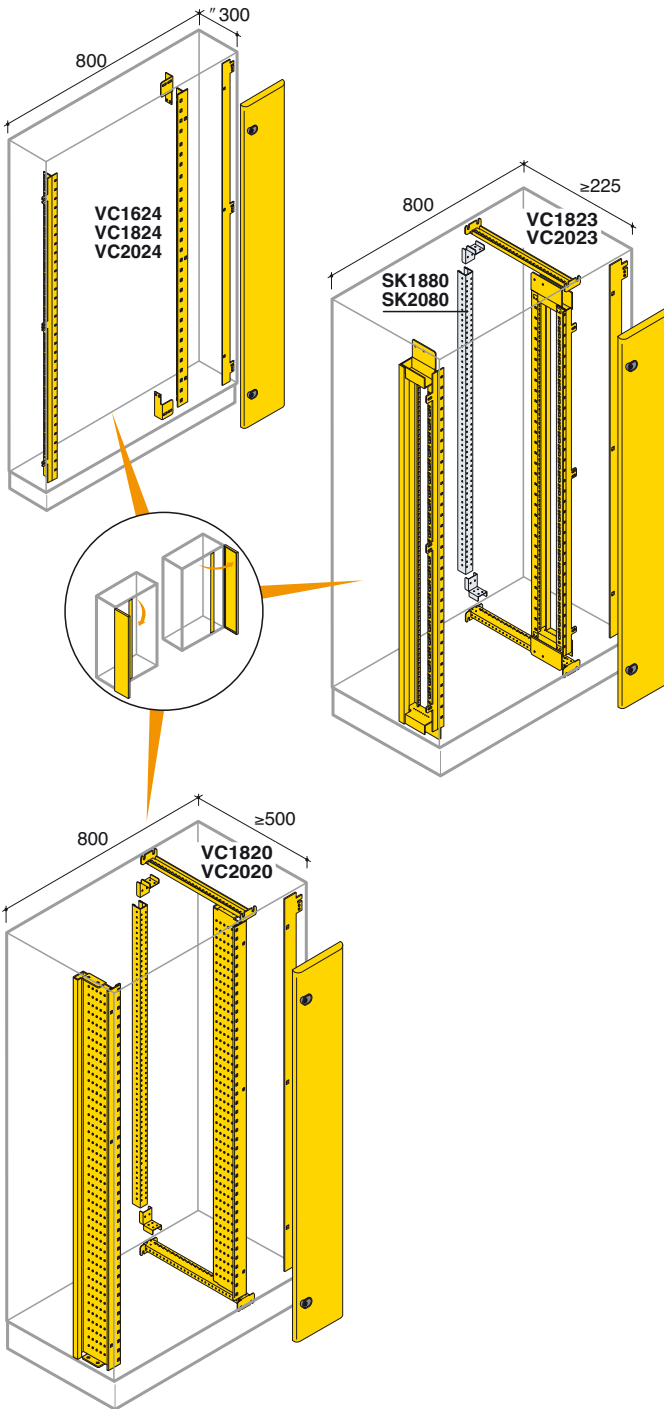

Internal cable container for switchgear without segregation (open frame)

Only to be ordered for the 36 DIN mod. structures (W=800mm). Consisting of a pair of functional uprights and a blind door complete with two key locks. Can be mounted either on the right or left.

Code	Description	Dimensions HxW(mm)
Reduced frame D≤300mm	Standard frame D≥225mm	
VC1624	Internal cable container	1600x200
VC1824	VC1823 Internal cable container	1800x200
VC2024	VC2023 Internal cable container	2000x200

Rear riser for unsegregated internal cable container

Kit consisting of 2 unsegregated functional frames and one blind door. The rear riser SK1880 (H=1800mm) and SK2080 (H=2000mm) in the unsegregated structures must be ordered separately if needed for fixing onto the rear of crosspieces, accessories, busbars, etc.

Code	Description	Dimensions H (mm)
SK1880	Internal cable container rear riser	1800
SK2080	Internal cable container rear riser	2000

Internal cable container for segregated switchgear (closed frame)

Only to be ordered for the W=800mm structures. Kit consisting of 2 functional segregated frames, a blind door and a rear upright for fixing onto the back of crosspieces, accessories, busbars, etc. Can be mounted either on the right or left.

Code	Description	Dimensions HxW (mm)
VC1820	Internal cable container for segregated switchgear D≥500mm	1800x200
VC2020	Internal cable container for segregated switchgear D≥500mm	2000x200

1STC802748F0001

ArTu K (without segregation/segregated) Structure

Base-Header-Plinth for external cable container

Pre-mounted structure complete with cable entry flanges, plinth channels and front flanges – the lateral ones must be ordered separately.

Code	Description	Dimensions D (mm)
W=300mm		
VC3025	Base, top and base strip for external cable container	150
VC3040	Base, top and base strip for external cable container	225
VC3050	Base, top and base strip for external cable container	300
VC3060	Base, top and base strip for external cable container	500
VC3080	Base, top and base strip for external cable container	700
VC3010	Base, top and base strip for external cable container	900

Front and rear coverings for additional cable container IP31 Internal door

Code	Description	Dimensions W (mm)
H=1600mm H=1800mm H=2000mm		
PO1631	PO1831 PO2031 Internal door for cable container	300

IP65 External door

Code	Description	Dimensions W (mm)
H=1600mm H=1800mm H=2000mm		
PO1633	PO1833 PO2033 External door for cable container	300

IP65 Rear panel

Code	Description	Dimensions W (mm)
H=1600mm H=1800mm H=2000mm		
RF1630	RF1830 RF2030 Rear panel	300

The additional cable container can be completed in the following ways:
 - IP65 version with external door (internal optional)
 - IP31 version with internal door and finishing section (see table on page 9/54).

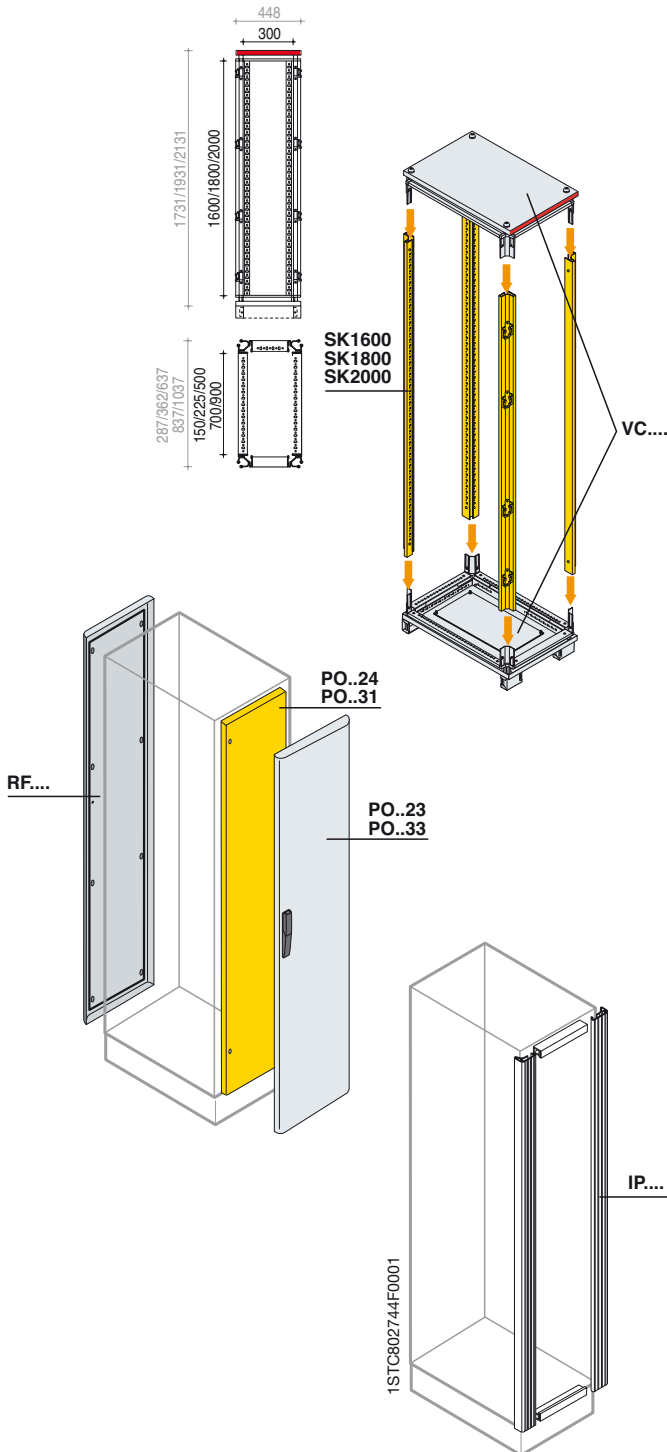

ArTu K (without segregation/segregated)

Kit for apparatus

Width 600/800mm
PM2424/PM2624/PM2836

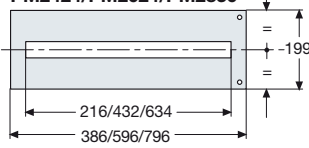

Version for Tmax with mod. diff.
PM2312/PM2315

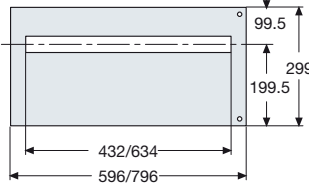

Version for Unifix H
PM3424/PM3624/PM3836

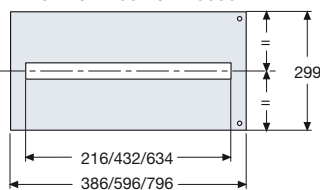

Width 600/800mm
PM3648/PM3872

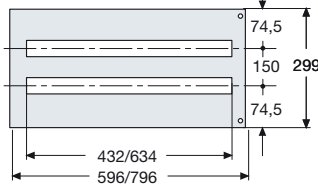

Width 600mm
PM6672

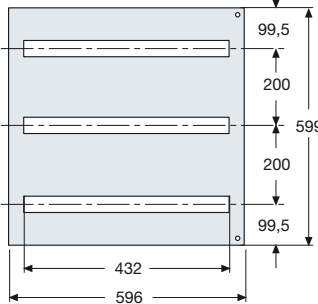

Width 600/800mm
PS4720/PS4728/PS4960/PS4968

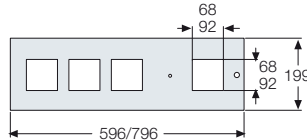

Width 600/800mm
PS2720/PS2728/PS2960/PS2968

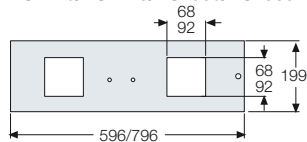

Panels for square measuring instruments

Code	Description	Dimensions HxW (mm)
24 DIN mod W=600mm	36 DIN mod W=800mm	
PS2720	PS2728 Panel for 2 instruments 72x72mm	200x600
PS2960	PS2968 Panel for 2 instruments 96x96mm	200x600
PS4720	PS4728 Panel for 4 instruments 72x72mm	200x600
PS4960	PS4968 Panel for 4 instruments 96x96mm	200x600

Modular panel

Code	Description	Dimensions H (mm)	
12 DIN mod W=390mm	24 DIN mod W=600mm	36 DIN mod W=800mm	
PM2424	PM2624	PM2836 Modular panel 1 DIN row	200
	PM2312	PM2315 Modular panel 1 DIN row - Tmax RC	300
	PM3624	PM3836 Modular panel 1 DIN row only for Unifix H	300
PM3424	PM3648	PM3872 Modular panel 2 DIN rows	300
	PM6672	Modular panel 3 DIN rows	600

1STC802745F0001

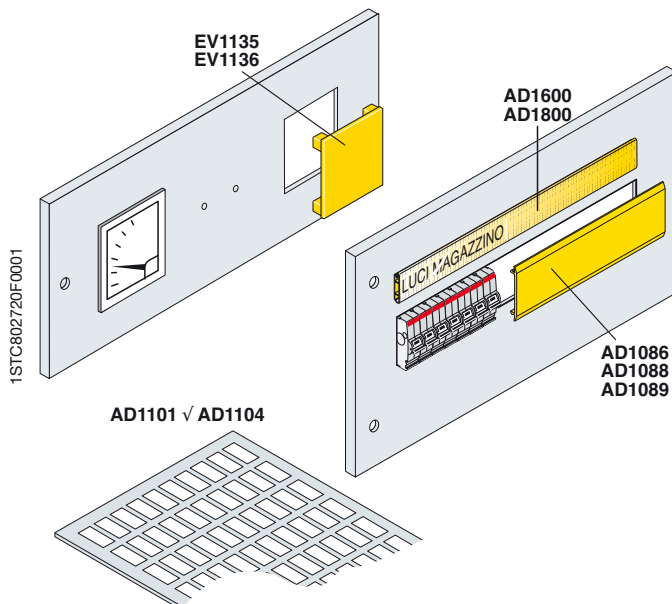

1STC802720F0001

Accessories for panels

Code	Description
AD1086	N°10 holes covers W=2000mm grey RAL 7035 colour
AD1088	N°3 holes covers 36 Din modules grey RAL 7035 colour
AD1089	N°3 holes covers 36 Din modules grey RAL 7035 colour
EV1135	N°10 closing caps for instrument panel 72x72mm
EV1136	N°5 closing caps for instrument panel 96x96mm
AD1390	N°20 label-holders 12 DIN mod.
AD1600	N°20 label-holders 24 DIN mod.
AD1800	N°20 label-holders 36 DIN mod.
AD1101 ⁽¹⁾	N°288 labels 1 mod. 15x17mm (HxW)
AD1102 ⁽¹⁾	N°192 labels 2 mod. 15x27mm (HxW)
AD1103 ⁽¹⁾	N°96 labels 3 mod. 15x50mm (HxW)
AD1104 ⁽¹⁾	N°96 labels 4 mod. 15x67mm (HxW)

⁽¹⁾ Labels can be written with Grafoplast compatible plotter system.

ArTu K (without segregation/segregated)

Kit for apparatus

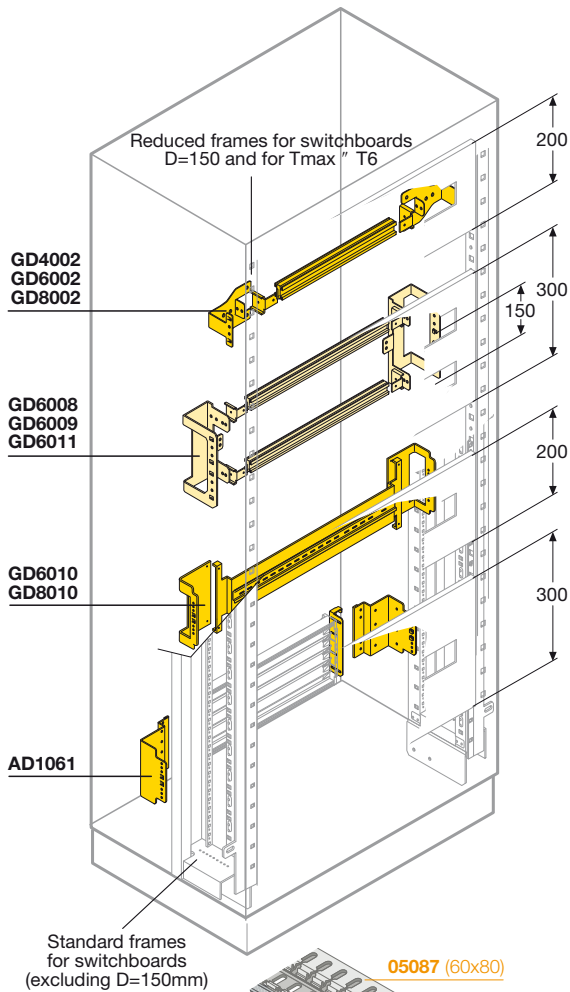

DIN rail kits for System Pro-M modular, Tmax T1-T2-T3, moulded-case circuit-breakers

Code			Description
12 DIN mod	24 DIN mod	36 DIN mod	
W=390mm	W=600mm	W=800mm	
GD4002	GD6002	GD8002	DIN rail kit (aluminium)
GD6011	GD6008	GD6009	DIN rail kit interaxis 150mm (2 DIN rows)
	GC6002⁽¹⁾	GC8002⁽¹⁾	DIN rail kit with accessories
	GD6010	GD8010	DIN rail kit reinforced for Tmax RC

⁽¹⁾ The DIN rail Kit with accessories includes the 60x80 wiring duct and relative fixing supports AD1037.

Supports for Unifix H

Code	Description	Dimensions H (mm)
AD1061	Fixing supports for Unifix H series for panel H=300mm	600/800

Depth adapter

Code	Description	Dimensions W (mm)
AP6000	N°1 depth adapter for Tmax T1-T2-T3	600

Supports for duct

Code	Description
AD1009	N°4 plastic supports for horizontal duct
AD1037	N°4 metal supports for horizontal duct

Tmax XT Flanges for DIN-Rail mounting

Code	Description
AD3301	XT1 3P flange for DIN-Rail mounting
AD3302	XT1 4P flange for DIN-Rail mounting
AD3303	XT3 3P flange for DIN-Rail mounting
AD3304	XT3 4P flange for DIN-Rail mounting

Already supplied in the DIN-Rail mounting kit for breakers in MCCBs catalogue
1SDC210033D0901

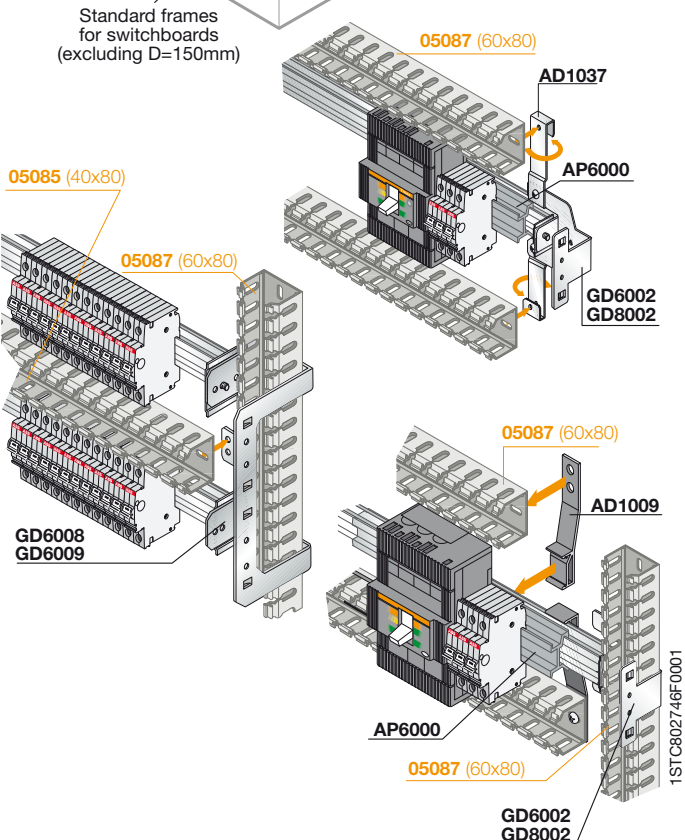

ArTu K (without segregation/segregated) Kit for apparatus

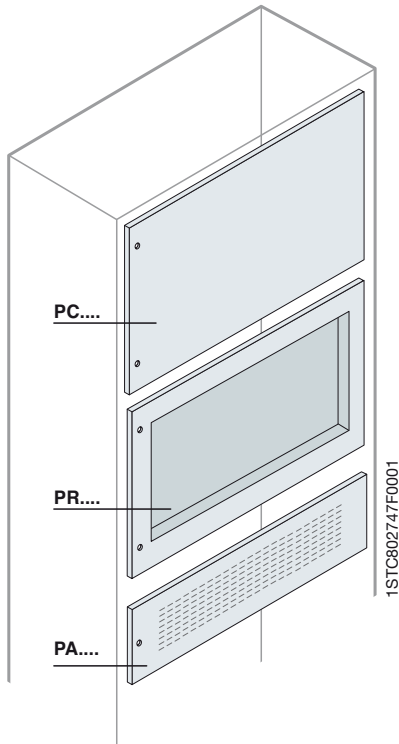

Blind, recessed and ventilated panels for general apparatus

Code			Description	Dimensions H (mm)
12 DIN mod W=390mm			24 DIN mod W=600mm	36 DIN mod W=800mm
PC1400	PC1600	PC1800	Blind panel	100
PC2400	PC2600	PC2800	Blind panel	200
PC3400	PC3600	PC3800	Blind panel	300
PC4400	PC4600	PC4800	Blind panel	400
PC6400	PC6600	PC6800	Blind panel	600
	PC8600	PC8800	Blind panel	800
	PC1660	PC1680	Blind panel	1600
PC1840	PC1860	PC1880	Blind panel	1800
PC2040	PC2060	PC2080	Blind panel	2000
	PR2600	PR2800	Blind recessed panel	200
	PR4600	PR4800	Blind recessed panel	400
	PR6600	PR6800	Blind recessed panel	600
	PA1600		Ventilated panel	100
	PA2600		Ventilated panel	200

ArTu K (without segregation)

Kit for switchgear with reduced frame D=150-225-300mm

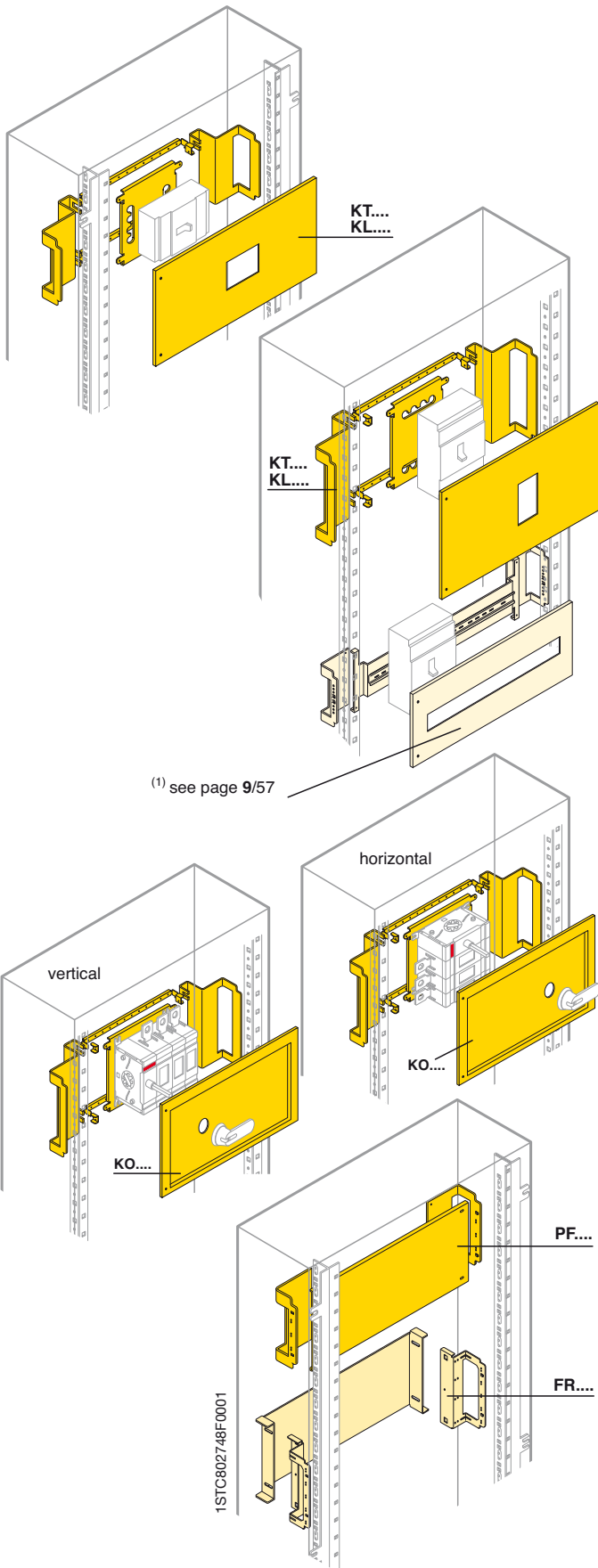

(1) see page 9/57

Kit for installing Tmax circuit-breakers front terminals

Horizontal installation (front terminals)

Code	Description	Dimensions H (mm)
24 DIN mod	36 DIN mod	
W=600mm	W=800mm	
KT1117	Kit for T1 3-4 poles fixed	200
KT1102	Kit for T1 4 poles fixed + RC mod.	200
KT2117	Kit for T2 3-4 poles fixed	200
KT2102	KL2103 Kit for T2 4 poles fixed + RC mod.	200
KT3112	KL3113 Kit for T3 3-4 poles fixed	200
KT3102	KL3103 Kit for T3 4 poles fixed + RC mod.	300
KT4112	KL4115 Kit for T4 3-4 poles fixed	200
KT4110	KL4116 Kit for T4 4 poles fixed + RC mod.	200
KT5112	KL5114 Kit for T5 3-4 poles fixed	300
KT5110	KL5116 Kit for T5 4 poles fixed + RC mod.	300
KT6113	KL6113 Kit for T6 3-4 poles fixed	500
KX1617	Tmax XT1	200
KX1602	Tmax XT1 CB + diff. mod.	200
KX2619	Tmax XT2	200
KX2602	Tmax XT2 CB + diff. mod.	200
KX3614	KL3613 Tmax XT3	200
KX3602	KX3603 Tmax XT3 CB + diff. mod.	300
KX4614	KX4615 Tmax XT4	200
KX4610	Tmax XT4 CB + diff. mod.	200

Vertical installation (front terminal)

Code	Description	Dimensions H (mm)
24 DIN mod	36 DIN mod	
W=600mm	W=800mm	
GD... ⁽¹⁾	GD... ⁽¹⁾ Kit on DIN rail for T1-T2-T3 3-4 poles fixed/RC	200/600
KT3212	Kit for T3 3-4 poles fixed	300
KT4212	Kit for T4 3-4 poles fixed	400
KT4102	Kit for T4 4 poles fixed + RC mod.	500
KT5212	KL5212 Kit for T5 3-4 poles fixed	400
KT5102	KL5102 Kit for T5 4 poles fixed + RC mod.	500
KT6213	KL6213 Kit for T6 3-4 poles fixed	500
KX1618	KX1618 Tmax XT1	200
KX1603	KX1603 Tmax XT1 CB + diff. mod.	300
KX1604	KX1604 Tmax XT1 N 3 CBs side by side	200
KX3612	KX3612 Tmax XT3	300
KX3609	KX3609 Tmax XT3 CB + diff. mod.	300
KX4612	KX4612 Tmax XT4	300
KX4602	KX4602 Tmax XT4 CB + diff. mod.	400

for 3 poles breakers please order accessory flange code AD3305 XT1 3P Flange for plate-mounting, AD3306 XT2 3P Flange for plate-mounting, AD3307 XT3 3P Flange for plate-mounting, AD3308 XT4 3P Flange for plate-mounting

For the Isomax kits see page 9/83 .

Kit for OT

Code	Description	Dimensions H (mm)
24 DIN mod	36 DIN mod	
W=600mm	W=800mm	
KO1201	Kit for OT200/250/315/400 - vertical installation	300
KO2260	KO2280 Kit for OT200/250/315/400 - horizontal installation	300
KO2261	KO2281 Kit for OT200/250/315/400 - vertical installation	300

Blind back plates for general apparatus

Code	Description	Dimensions H (mm)
24 DIN mod	36 DIN mod	
W=600mm	W=800mm	
PF2610	PF2810 Blind back plate	200
PF4610	PF4810 Blind back plate	400
FR2601	FR2801 Blind recessed back plate	200
FR4601	FR4801 Blind recessed back plate	400

The panels must be ordered separately.

ArTu K (without segregation)

Kit for switchgear with standard frame $D \geq 225\text{mm}$

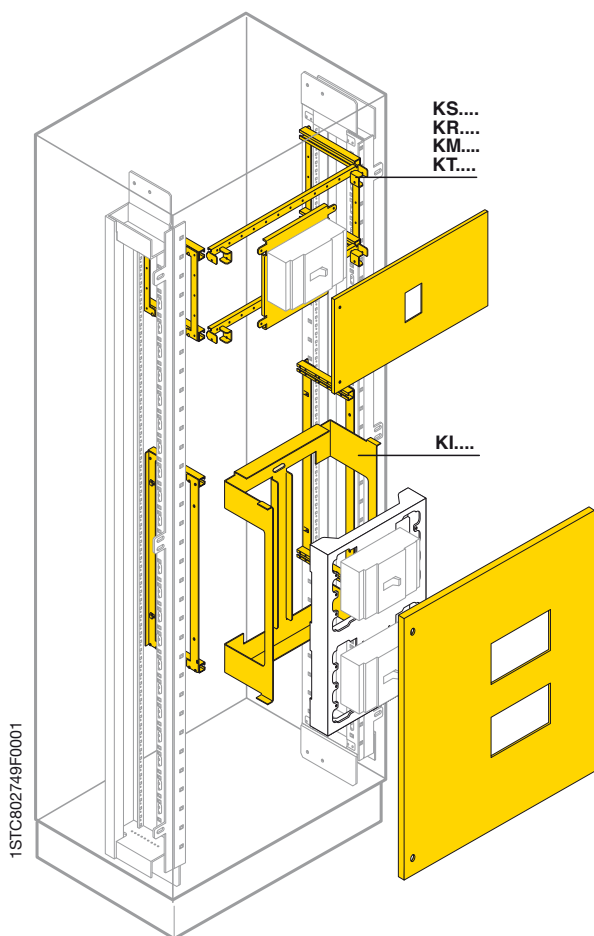

Kit for installing Tmax circuit-breakers

Horizontal installation (front or rear terminals)

Code			Description	Dimensions H (mm)
12 DIN mod W=390mm	24 DIN mod W=600mm	36 DIN mod W=800mm		
KT1411(*)			Kit for T1 3-4 poles fixed (MO)	200
	KT1111		Kit for T1 4 poles fixed + RC mod.	200
KT1401(*)	KT1101(*)	KL1102(*)	Kit for T1 3-4 poles fixed (DRH)	200
	KT1112		Kit for T2 3-4 poles fixed	200
	KT2411		Kit for T2 3-4 poles fixed (MO)	200
	KT2111		Kit for T2 4 poles fixed + RC mod.	200
KT2401(*)	KT2101(*)	KL2104(*)	Kit for T2 3-4 poles plug-in	200
KT2421	KT2121		Kit for T2 3-4 poles fixed (DRH)	200
	KT2112		Kit for T3 4 poles fixed	200
KT3419 (*)		KL3114	Kit for T3 3-4 poles fixed (MO)	200
	KT3119		Kit for T3 3-4 poles fixed (I-IM)	200
	KT3131(**)		Kit for T3 4 poles fixed + RC mod.	500
KT3401 (*)	KT3101(*)	KL3104(*)	Kit for T3 4 poles fixed (DRH)	300
	KT3114		Kit for T3 3-4 poles plug-in	200
KT3421			Kit for T3 3-4 poles plug-in (MO)	200
	KT3121		Kit for T3 3-4 poles plug-in (DRH)	200
	KT3116		Kit for T4 4 poles fixed	200
KT4411			Kit for T4 4 poles fixed (DRH-MO)	200
	KT4111		Kit for T4 4 poles fixed + RC mod.	200
	KT4101		Kit for T4 3-4 poles plug-in	200
	KT4122		Kit for T4 3-4 poles withdrawable (DRH)	200
	KT4127		Kit for T4 3-4 poles withdrawable (MO)	300
	KT4125		Kit for T4 3-4 poles fixed/plug-in (I-IM)	300
	KI4114(**)		Kit for T4 3-4 poles withdrawable (I-IM)	600
	KI4115(**)		Kit for T5 3-4 poles fixed	600
KT5411			Kit for T5 3-4 poles fixed (DRH-MO)	300
	KT5111		Kit for T5 3-4 poles fixed	300
		KL5115	Kit for T5 4 poles fixed + RC mod.	300
	KT5101	KL5101	Kit for T5 (400A) 3-4 poles plug-in	300
	KT5120		Kit for T5 (630A) 3-4 poles plug-in	300
	KT5121		Kit for T5 (400A) 3-4 poles withd. (DRH)	300
	KT5130		Kit for T5 (630A) 3-4 poles withd. (DRH)	300
	KT5131		Kit for T5 (400A) 3-4 poles withd. (MO)	300
	KT5134		Kit for T5 (630A) 3-4 poles withd. (MO)	300
	KT5135		Kit for T5 3-4 poles fixed/plug-in (I-IM)	300
	KI5114(**)		Kit for T5 3-4 poles plug-in (I-IM)	600
	KI5115(**)		Kit for T6 3-4 poles fixed	600
	KT6111		Kit for T6 3-4 poles withdrawable (DRH)	500
	KT6131		Kit for T6 3-4 poles fixed (DRH)	500
	KT6112		Kit for T6 3-4 poles fixed (MO)	500
	KT6115		Kit for T6 3-4 poles withdrawable (MO)	500
	KT6114		Kit for T6 3-4 poles fixed (I)	500
	KT6116(**)		Kit for T6 3-4 poles fixed (IM)	800
	KT6117(**)		Kit for T6 3-4 poles withdrawable (I)	800
	KT6118(**)		Kit for T6 3-4 poles withdrawable (IM)	800
	KT6119(**)		Kit for T7 3-4 poles fixed	800
KT7110			Kit for T7 3-4 poles fixed	400
	KT7111⁽¹⁾	KL7112	Kit for T7M 3-4 poles fixed (MO)	400
			Kit T7M 3/4 poles fixed (CM)	400
KX1419	KX1611		Tmax XT1	200
	KX1609	KX1801	Tmax XT1 CB + diff. mod.	200
KX2411	KX2611		Tmax XT2	200
	KX2601	KX2801	Tmax XT2 CB + diff. mod.	200
KX3411	KX3611	KX3811	Tmax XT3	200
	KX3601	KX3801	Tmax XT3 CB + diff. mod.	300
KX4411	KX4611		Tmax XT4	200
	KX4601		Tmax XT4 CB + diff. mod.	200
	KX2621		Tmax XT2 plug-in	200
	KX3621		Tmax XT3 plug-in	200
	KX4622		Tmax XT4 plug-in	200
	KX4627		Tmax XT4 withdrawable	300
	KX1605		Tmax XT1 DRH	200
	KX2605		Tmax XT2 DRH	200
	KX3605		Tmax XT3 DRH	200
	KX1131		Tmax XT3 with XT1 interlocked	500
	KX3131		Tmax XT3 interlocked	500
	KX4141		Tmax XT4 interlocked	500

(*) Only front terminals; (**) Only rear terminals.

(1) If used with rotary handle, use the protruding door **PV.63** and **PV.83**.

Also allows installation of Emax X1.

(DRH) = Direct rotary handle; (MO) = Motor operator; (I) = Interlocked; (IM) = Interlocked motor operated.

for 3 poles breakers please order accessory flange code AD3305 XT1 3P Flange for plate-mounting; AD3306 XT2 3P Flange for plate-mounting; AD3307 XT3 3P Flange for plate-mounting; AD3308 XT4 3P Flange for plate-mounting

For the Isomax kits see page 9/83

ArTu K (without segregation)

Kit for switchgear with standard frame $D \geq 225\text{mm}$

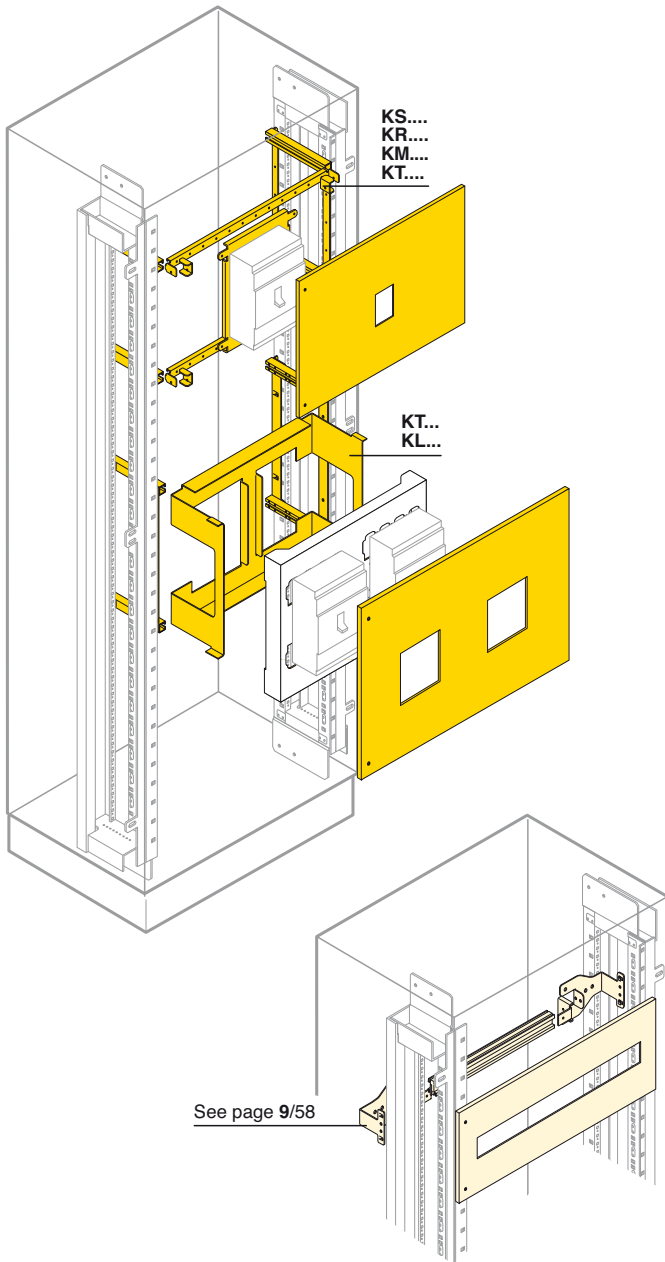

Kit for installing Tmax circuit-breakers

Vertical installation (front or rear terminals)

Code			Description	Dimensions H (mm)
12 DIN mod				
24 DIN mod				
36 DIN mod				
W=390mm	W=600mm	W=800mm		
GD...⁽¹⁾	GD...⁽¹⁾	GD...⁽¹⁾	Kit on DIN rail for T1 3-4 poles fixed	200÷600
KT3416	KT3211	KL3212	Kit for T3 3-4 poles fixed	300
KT3426	KT3221		Kit for T3 3-4 poles plug-in	400
KT4412			Kit for T4 3-4 poles fixed	400
	KT4211		Kit for T4 3-4 poles fixed (DRH-MO)	400
	KT4116		Kit for N°3 T4 3-4 poles fixed	400
		KL4118	Kit for N°4 T4 3-4 poles fixed	400
	KT4103		Kit for T4 4 poles fixed + RC mod.	500
	KT4221		Kit for T4 3-4 poles plug-in	400
	KT4231		Kit for T4 3-4 poles plug-in (DRH)	400
	KT4126		Kit for T4 3-4 poles withdrawable (MO)	400
KT5412		KL5213	Kit for T5 3-4 poles fixed	400
	KT5211		Kit for T5 3-4 poles fixed (DRH-MO)	400
	KT5103	KL5103	Kit for T5 4 poles fixed + RC mod.	500
	KT5214		Kit for N°2 T5 3-4 poles fixed	400
		KL5214	Kit for N°3 T5 3-4 poles fixed	400
	KT5117		Kit for N°2 T5 4 poles fixed + RC mod.	500
		KL5117	Kit for N°3 T5 4 poles fixed + RC mod.	500
	KT5222		Kit for T5 (400A) 3-4 poles plug-in	400
	KT5221		Kit for T5 (630A) 3-4 poles plug-in	400
	KT5232		Kit for T5 (400A) 3-4 poles withdraw. (DRH)	400
	KT5138		Kit for T5 (400A) 3-4 poles withdraw. (MO)	400
	KT5139		Kit for T5 (630A) 3-4 poles withdraw. (MO)	500
	KT5231		Kit for T5 (630A) 3-4 poles withdraw. (DRH)	500
KT5401			Kit for T5 3-4 poles fixed + RC mod.	500
	KT6211	KL6214	Kit for T6 3-4 poles fixed	500
		KL6124	Kit for N°2 T6 3-4 poles fixed	500
	KT6122		Kit for T6 3-4 poles fixed (DRH)	500
	KT6120		Kit for T6 3-4 poles fixed (DRH)	500
	KT6121		Kit for T6 3-4 poles fixed (MO)	500
	KT6123		Kit for T6 3-4 poles withdrawable (MO)	500
	KT7211⁽¹⁾	KL7212	Kit for T7 3-4 poles fixed	500
			Kit for T7M 3/4 poles fixed (MO-I-M)	500
	KT7231	KL7213	Kit for T7 3-4 poles withdrawable	500
			Kit for T7M 3/4 poles withdr. (MO-I-M)	500
		KT8211	Kit for T8 3-4 poles fixed	800
KX3412	KX3613	KX3812	Tmax XT3	300
KX4412	KX4617		Tmax XT4	300
	KX4603		Tmax XT4 CB + diff. mod.	400
	KX4616		Tmax XT4 N 2 CBs side by side	300
		KX4818	Tmax XT4 N 3 CBs side by side	300

for 3 poles breakers please order accessory flange code AD3305 XT1 3P Flange for plate-mounting; AD3306 XT2 3P Flange for plate-mounting, AD3307 XT3 3P Flange for plate-mounting, AD3308 XT4 3P Flange for plate-mounting

⁽¹⁾ For selection of the installation kits, see the table on page 9/61.

⁽²⁾ If used with rotary handle, use the protruding door **PV.63** and **PV.83**.

(DRH) = Direct rotary handle; (MO) = Motor operator; (I) = Interlocked; (IM) = Interlocked motor operated.

For the Isomax kits see page 9/83.

Kit for installing Emax circuit-breakers X1-E1-E2-E3-E4

Vertical installation

Code		Description	Dimensions H (mm)
24 DIN mod			
36 DIN mod			
W=600mm	W=800mm		
KT7211	KL7212	Kit for X1 3/4 poles fixed	500
KT7231	KL7213	Kit for X1 3/4 poles withdrawable	500
KE3215⁽¹⁾		Kit for E1-E2-E3 3/4 poles fixed	600
KE3235⁽¹⁾		Kit for E1-E2-E3 3/4 poles withdr.	600
	KE4215⁽²⁾	Kit for E3 3-4 poles fixed	600
	KE4235⁽²⁾	Kit for E3 3-4 poles withdrawable	600
	KE5215⁽²⁾	Kit for E4 3-4 poles fixed	600
	KE5235⁽²⁾	Kit for E4 3-4 poles withdrawable	600

for 3 poles breakers please order accessory flange code AD3305 XT1 3P Flange for plate-mounting; AD3306 XT2 3P Flange for plate-mounting, AD3307 XT3 3P Flange for plate-mounting, AD3308 XT4 3P Flange for plate-mounting

⁽¹⁾ Also for E1-E2 interlocked version.

⁽²⁾ Also for interlocked version.

ArTu K (without segregation)

Kit for switchgear with standard frame $D \geq 225\text{mm}$

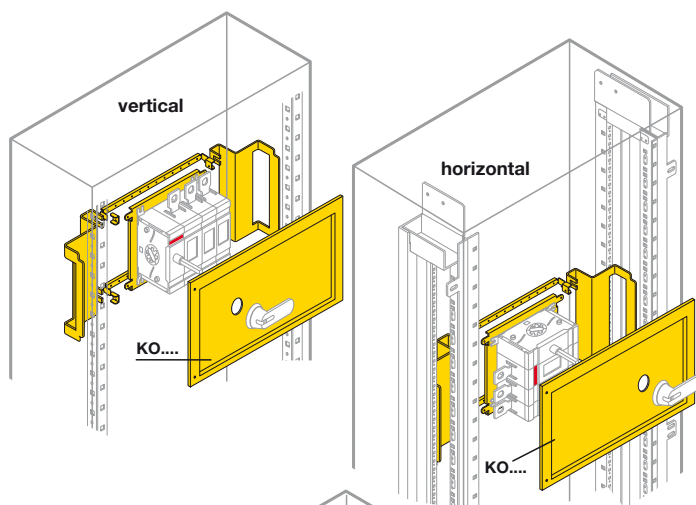

Kit for OT/OETL

Code	Description	Dimensions H (mm)
24 DIN mod 36 DIN mod W=600mm W=800mm		
KO1201	Kit for OT125/160 - vertical	300
KO2260 KO2280	Kit for OT200/250/315/400 - vertical	300
KO2261 KO2281	Kit for OT200/250/315/400 - horizontal	300
KO3660 KO3680	Kit for OT630/800 - vertical	400
KO1250	Kit for OETL1000/1600	600

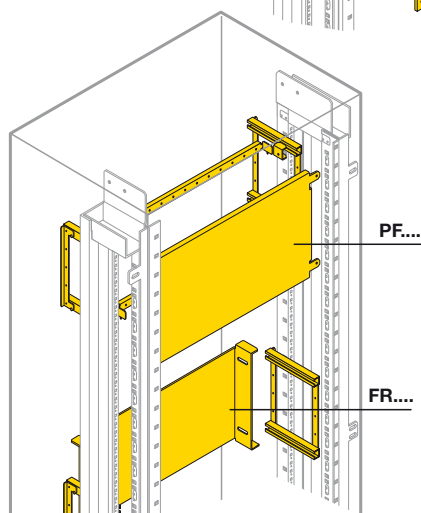

Blind back plates for general apparatus

Code	Description	Dimensions H (mm)
12 DIN mod 24 DIN mod 36 DIN mod W=390mm W=600mm W=800mm		
PF2401 PF2601 PF2801	Blind back plate	200
PF3403 PF3601 PF3801	Blind back plate	300
PF4401 PF4601 PF4801	Blind back plate	400
PF6401 PF6601 PF6801	Blind back plate	600
FR2600 FR2800	Blind recessed back plate	200
FR4600 FR4800	Blind recessed back plate	400
FR6600 FR6800	Blind recessed back plate	600

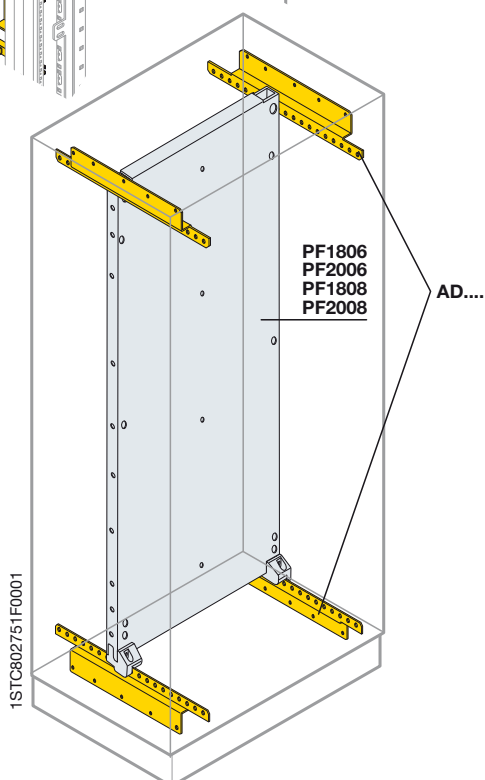

Back plates

Code	Description	Dimensions H (mm)
24 DIN mod 36 DIN mod W=600mm W=800mm		
PF1806 PF1808	Galvanised sheet back plate	1800
PF2006 PF2008	Galvanised sheet back plate	2000

Tracks for back plate

Code	Description
AD1049	Pair of tracks + crosspieces for structures $D=225\text{mm}$
AD1050	Pair of tracks + crosspieces for structures $D=500\text{mm}$
AD1051	Pair of tracks + crosspieces for structures $D=700\text{mm}$

ArTu K (segregated)

Kit for switchgear with segregated frame $D \geq 225\text{mm}$

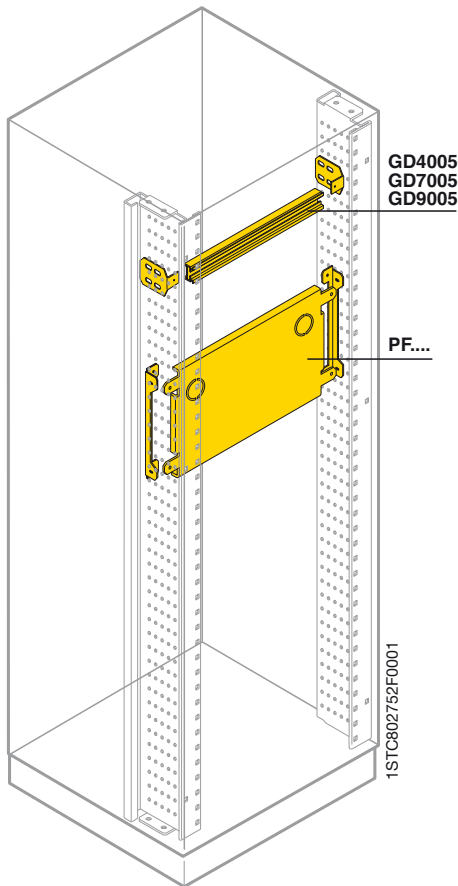

DIN rail kit for System Pro-M modular, Tmax T1-T2-T3, moulded-case circuit-breakers

Code			Description
12 DIN mod W=390mm	24 DIN mod W=600mm	36 DIN mod W=800mm	
GD4005	GD7005	GD9005	DIN rail kit (aluminium)

Blind back plates for general apparatus

Code			Description	Dimensions H (mm)
12 DIN mod W=390mm	24 DIN mod W=600mm	36 DIN mod W=800mm		
PF2405	PF2005	PF2805	Blind back plate	200
PF3405	PF3005	PF3805	Blind back plate	300
PF4405	PF4005	PF4805	Blind back plate	400
PF6405	PF6005	PF6805	Blind back plate	600
	PF8005	PF8805	Blind back plate	800

ArTu K (segregated)

Kit for switchgear with segregated frame $D \geq 500\text{mm}$

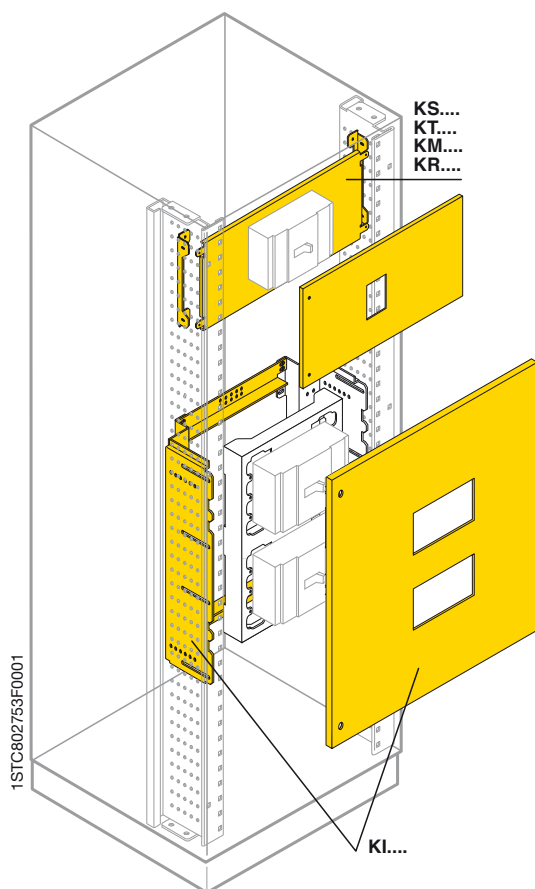

Kit for installing Tmax circuit-breakers

Horizontal installation (rear terminals)

Code	Description	Dimensions H (mm)
12 DIN mod 24 DIN mod		
W=390mm W=600mm		
KT1410	KT1110 Kit for T1 3-4 poles fixed	200
	KT1100 Kit for T1 3-4 poles fixed + RC mod.	200
KT2410	KT2110 Kit for T2 3-4 poles fixed	200
	KT2210 Kit for T2 3-4 poles fixed (DRH)	200
KT2420	KT2120 Kit for T2 3-4 poles plug-in	200
KT3410	KT3110 Kit for T3 3-4 poles fixed	200
	KT3115 Kit for T3 3-4 poles fixed (DRH)	200
KT3420	KT3120 Kit for T3 3-4 poles plug-in	200
	KT3124 Kit for T3 3-4 poles (DRH) plug-in	200
	KT3132 Kit for T3 3-4 poles fixed (I-IM)	600
KT4120	Kit for T4 3-4 poles fixed	200
	KT4124 Kit for T4 3-4 poles fixed (DRH)	200
	KT4310 Kit for T4 3-4 poles fixed (MO)	200
	KT4113 Kit for T4 3-4 poles plug-in	200
	KI4116 Kit for T4 3-4 poles (I-IM) plug-in	600
	KI4119 Kit for T4 3-4 poles (I-IM) plug-in	600
	KT4130 Kit for T4 3-4 poles withdrawable (DRH)	300
	KT4320* Kit for T4 3-4 poles withdrawable (MO)	300
	KI4117 Kit for T4 3-4 poles withdrawable (I)	600
	KI4118 Kit for T4 3-4 poles withdrawable (IM)	600
KT5122	Kit for T5 3-4 poles fixed	300
	KT5136 Kit for T5 3-4 poles fixed (DRH)	300
	KT5310 Kit for T5 3-4 poles fixed (MO)	300
	KI5116 Kit for T5 3-4 poles fixed and plug-in (I-IM)	600
	KI5119 Kit for T5 3-4 poles fixed and plug-in (I-IM)	600
	KT5420 Kit for T5 (400A) 3-4 poles plug-in	300
	KT5421 Kit for T5 (630A) 3-4 poles plug-in	300
	KT5430 Kit for T5 (400A) 3-4 poles withdrawable (DRH)	300
	KT5431 Kit for T5 (630A) 3-4 poles withdrawable (DRH)	300
	KT5320* Kit for T5 (400A) 3-4 poles withdrawable (MO)	300
	KT5321* Kit for T5 (630A) 3-4 poles withdrawable (MO)	300
	KI5117 Kit for T5 3-4 poles withdrawable (I)	600
	KI5118 Kit for T5 3-4 poles withdrawable (IM)	600
	KT6110 Kit for T6 3-4 poles fixed	500
	KT6220 Kit for T6 3-4 poles fixed (DRH)	500
	KT6221 Kit for T6 3-4 poles fixed (MO)	500
	KT6142 Kit for T6 3-4 poles fixed (I)	800
	KT6143 Kit for T6 3-4 poles fixed (IM)	800
	KT6130 Kit for T6 3-4 poles withdrawable	500
	KT6134 Kit for T6 3-4 poles withdrawable (MO)	500
	KT6144 Kit for T6 3-4 poles withdrawable (I)	800
	KT6145 Kit for T6 3-4 poles withdrawable (IM)	800
	KT7115 ⁽¹⁾ Kit for T7 3-4 poles fixed	400
	Kit for T7M 3-4 poles fixed (MO)	400
KY1411	KY1611 Tmax XT1	200
	KY1601 Tmax XT1 CB + diff. mod.	200
KY2411	KY2611 Tmax XT2	200
KY3411	KY3611 Tmax XT3	200
KY4411	KY4611 Tmax XT4	200
KY2421	KY2621 Tmax XT2 plug-in	200
KY3421	KY3621 Tmax XT3 plug-in	300
	KY4621 Tmax XT4 plug-in	200
	KY4631 Tmax XT4 withdrawable	300
	KY2605 Tmax XT2 DRH	200
	KY3605 Tmax XT3 DRH	200
	KY1131 Tmax XT3 with XT1 interlocked	500
	KY3131 Tmax XT3 interlocked	500
	KY4141 Tmax XT4 interlocked	500
	KY4604 Tmax XT4 + motor	200

for 3 poles breakers please order accessory flange code AD3305 XT1 3P Flange for plate-mounting; AD3306 XT2 3P Flange for plate-mounting, AD3307 XT3 3P Flange for plate-mounting, AD3308 XT4 3P Flange for plate-mounting

* Only segregation Form 2

⁽¹⁾ If used with rotary handle, use the protruding door **PV.63** and **PV.83**.

For the Isomax kits see page 9/83.

(DRH) = Direct rotary handle; (MO) = Motor operator; (I) = Interlocked; (IM) = Interlocked motor operated.

ArTu K (segregated)

Kit for switchgear with segregated frame $D \geq 500\text{mm}$

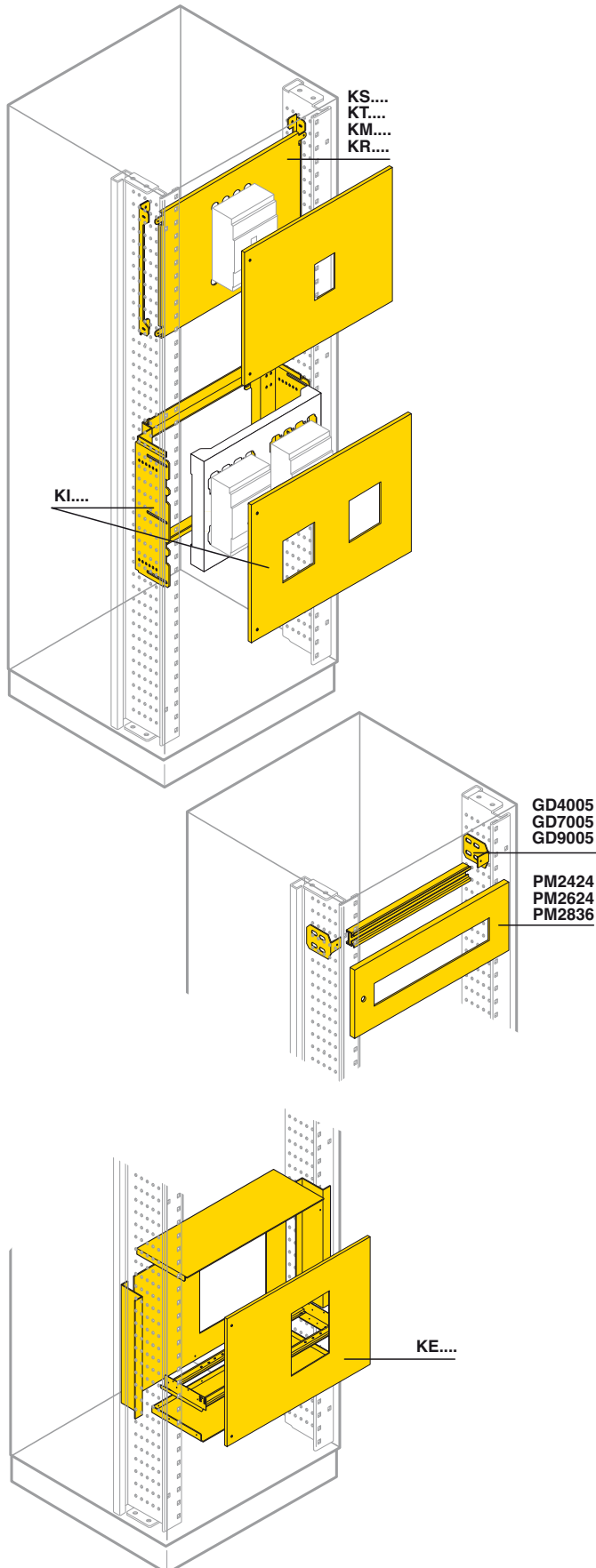

Kit for installation of Tmax circuit-breakers

Vertical installation (rear terminals)

Code		Description	Dimensions H (mm)
12 DIN mod 24 DIN mod 36 DIN mod			
W=390mm W=600mm W=800mm			
GD...(1)	GD...(1)	Kit for DIN T1-T2-T3, 3/4 poles fixed+RC mod.	200
KT4129	KT4121	Kit for T4 3/4 poles fixed	400
	KT4222	Kit for T4 3/4 poles plug-in	400
	KT4128	Kit for T4 3/4 poles withdrawable	400
KT5137	KT5128	Kit for T5 3/4 poles fixed	400
	KT5129	Kit for T5 (400A) 3/4 poles plug-in	400
KT5125	KT5123	Kit for T5 (630A) 3/4 poles plug-in	400
	KT5223	Kit for T5 (400A) 3/4 poles withdrawable	400
KT5126	KT5124	Kit for T5 (630A) 3/4 poles withdrawable	400
	KT6210	Kit for T6 3/4 poles fixed	500
	KT6230	Kit for T6 3/4 poles withdrawable (DRH)	500
	KT6132	Kit for T6 3/4 poles fixed (DRH)	500
	KT6133	Kit for T6 3/4 poles fixed (MO)	500
	KT6141	Kit for T6 3/4 poles withdrawable (MO)	500
	KT7215⁽²⁾	Kit for T7 3/4 poles fixed	500
		Kit for T7M 3/4 poles fixed (MO)	500
	KT7230	Kit for T7 3/4 poles withdrawable	500
		Kit for T7M 3/4 poles withdrawable (CM-I-IM)	500
	KT8210	Kit for S8 3/4 poles fixed	800
KY4412	KY4612	Tmax XT4	300

(DRH) = Direct rotary handle; (MO) = Motor operator; (I) = Interlocked; (IM) = Interlocked motor operated.

⁽²⁾ If used with rotary handle, use the protruding door **PV.63** and **PV.83**.

for 3 poles breakers please order accessory flange code AD3305 XT1 3P Flange for plate-mounting; AD3306 XT2 3P Flange for plate-mounting, AD3307 XT3 3P Flange for plate-mounting, AD3308 XT4 3P Flange for plate-mounting

For Isomax kits see page 9/83.

Kit for installation of Emax circuit-breakers

Vertical installation (rear terminals)

Code		Description	Dimensions H (mm)	
24 DIN mod 36 DIN mod				
W=600mm W=800mm				
	KT7215	Kit for X1 3/4 poles fixed	500	
	KT7230	Kit for X1 3/4 poles withdrawable	500	
	KE2215	Kit for E1-E2 3/4 poles fixed	600	
	KE2235	Kit for E1-E2 3/4 poles withdrawable	600	
	KE3205	KE4214	Kit for E3 3/4 poles fixed	600
	KE3236	KE4234	Kit for E3 3/4 poles withdrawable	600
		KE5214⁽¹⁾	Kit for E4 3/4 poles fixed (I)	600
		KE5234⁽¹⁾	Kit for E3 3/4 poles withdrawable (I)	600

⁽¹⁾ Also for interlocked version.

ArTu K (segregated)

Segregation

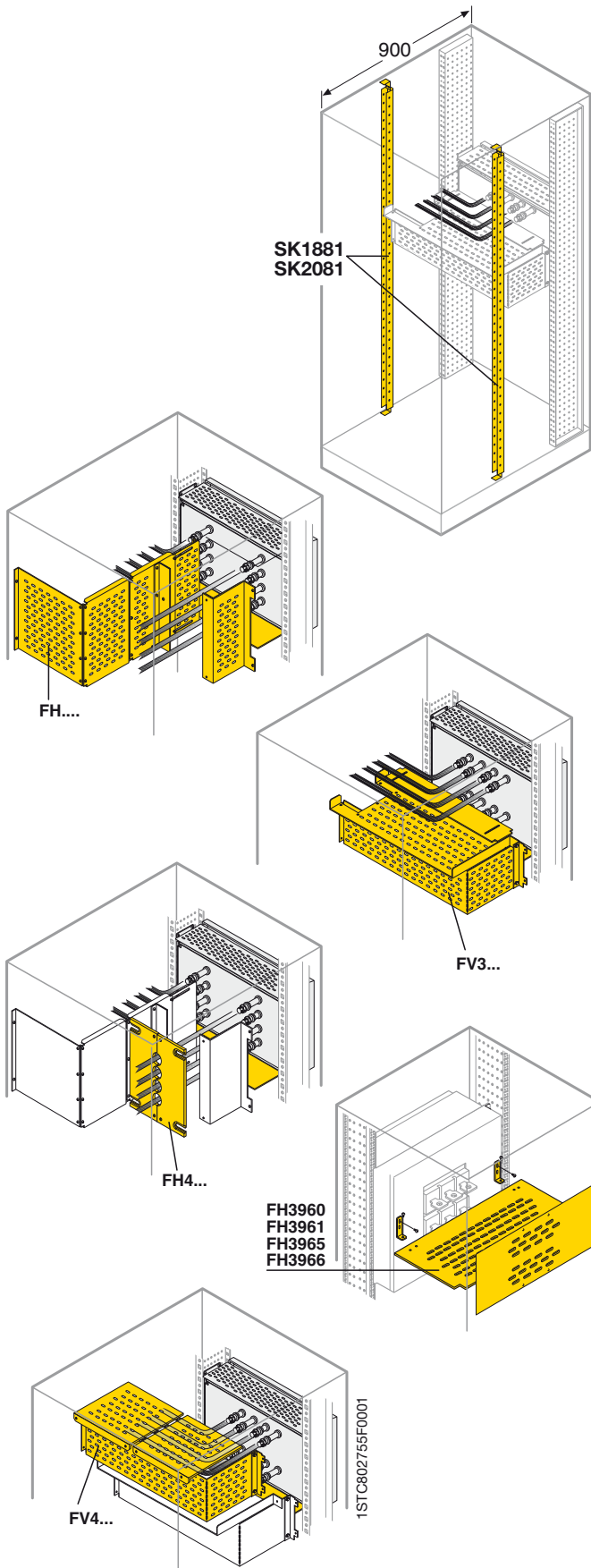

Intermediate upright for segregated structures D=900mm

Code	Description	Dimensions H (mm)
SK1881	SK1881 N°2 lateral intermediate uprights for switchgear D=900mm	1800
SK2081	SK2081 N°2 lateral intermediate uprights for switchgear D=900mm	2000

Segregation

Horizontal segregation

Code	Description	Dimensions HxD (mm)
Form 3 12 DIN mod W=390mm	Form 3 24 DIN mod W=600mm	
	Form 4	
FH3224	FH3220 + FH4220	Segregation kit 200x500/700
FH3434	FH3430 + FH4430	Segregation kit 300x500/700
FH3544	FH3540 + FH4540	Segregation kit 400x500/700
	FH3650 + FH4650	Segregation kit 500x500/700
	FH3680 + FH4220 (1)	Segregation kit 800x500/700
FH3764	FH3760 + FH4760	Segregation kit 600x500/700
	FH3780 + FH4220 (1)	Segregation kit 800x500/700
	FH1020 + FH4220	Segregation kit 200x900
	FH1030 + FH4430	Segregation kit 300x900
	FH1040 + FH4540	Segregation kit 400x900
	FH1050 + FH4650	Segregation kit 500x900
	FH1060 + FH4760	Segregation kit 600x900

(1) Order 4 pieces

Vertical segregation

Code	Description	Dimensions HxD (mm)
Form 3	Form 4	
FV3456	+ FV4456	Segregation kit 400x500
FV3458	+ FV4458	Segregation kit 400x700
FV3556	+ FV4556	Segregation kit 500x500
FV3558	+ FV4558	Segregation kit 500x700
FV3668	+ FV4668	Segregation kit 600x700
FV3788	+ FV4788	Segregation kit 800x700
FV4557		Segregation kit 600x700

Code	Description	Dimensions WxD (mm)
FH3960	Segregation kit Emax E1-E2-E3 fixed	600x700
FH3961	Segregation kit Emax E1-E2-E3 withdrawable	600x700
FH3965	Segregation kit Emax E4 fixed	800x900
FH3966	Segregation kit Emax E4 withdrawable	800x900

ArTu K (segregated)

Segregation

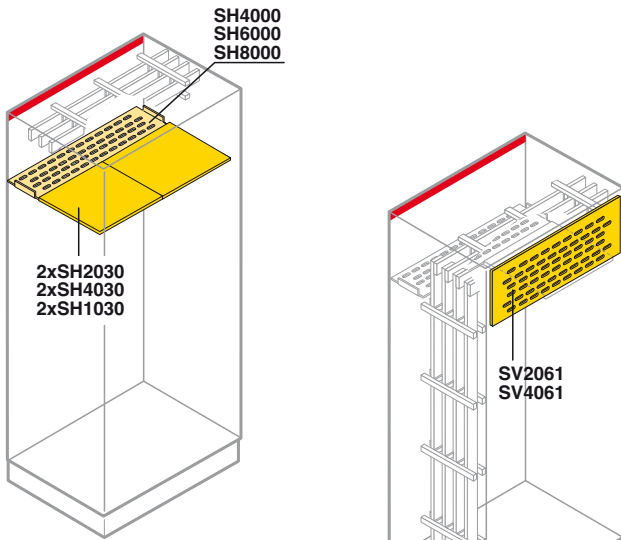

Segregation

Universal shelf

Code	Description		
12 DIN mod	24 DIN mod	36 DIN mod	
W=390mm	W=600mm	W=800mm	
SH4000	SH6000	SH8000	Universal busbar segregation shelf

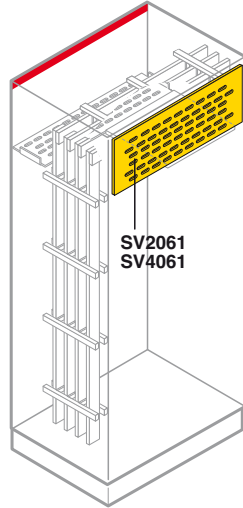

Busbar segregation

Code	Description	Dimensions D (mm)
12 DIN mod	24 DIN mod	
W=390mm	W=600mm	
SH4030	SH2030	Horizontal busbar segregation (down) 500/700
	SH1030	Horizontal busbar segregation (down) 900

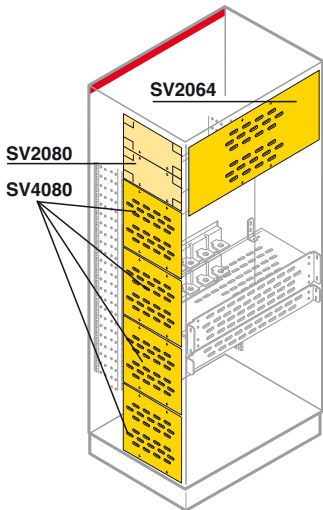

Code	Description	Dimensions H (mm)
12 DIN mod	24 DIN mod	
W=390mm	W=600mm	
SV4061	SV2061	Horizontal busbar segregation (rear) 200

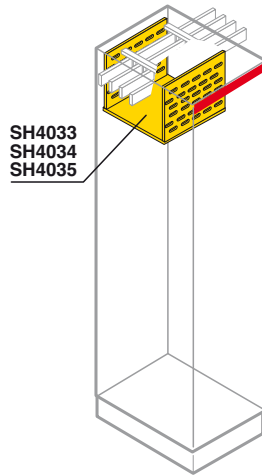

Code	Description	Dimensions D (mm)
H=1800mm	H=2000mm	
SV1860	SV2265	Horizontal busbar segregation (side) 500
SV1880	SV2285	Horizontal busbar segregation (side) 700
SV1815	SV2015	Horizontal busbar segregation (side) 900

Code	Description	Dimensions HxD (mm)
SV2080	Vertical segregation Emax (side)	200x700
SV4080	N 4 Vertical segregation Emax (side)	400x700

Code	Description	Dimensions HxW (mm)
SV2064	Vertical segregation Emax (rear)	400x600

Busbar segregation in the cable container

Code	Description	Dimensions LxD (mm)
SH4031	Horizontal busbar segregation in internal cable container	200x500/700
SH4033	Horizontal busbar segregation in additional cable container	300x500/700
SH4034	Horizontal busbar segregation in structure W=390 used as busbar container	400x500/700
SH4035	Horizontal busbar segregation in structure W=390 used as busbar container	600x500/700

Code	Description
H=1800mm	H=2000mm
AD1024	AD1025
	Internal cable container rear segregation

Accessories

Code	Description
AD1042	N°4 spacers for lateral segregation

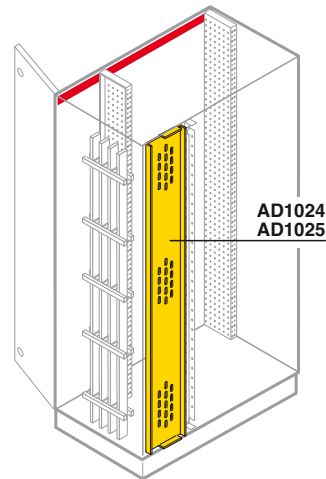
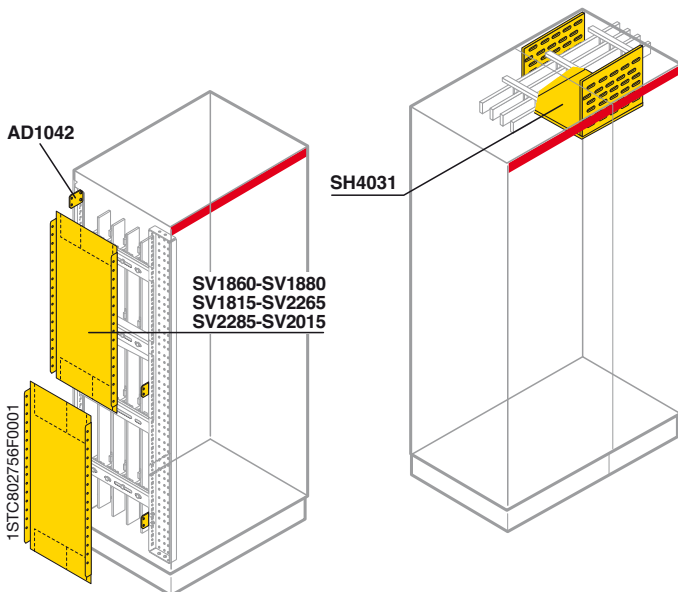

ArTu K

Distribution system

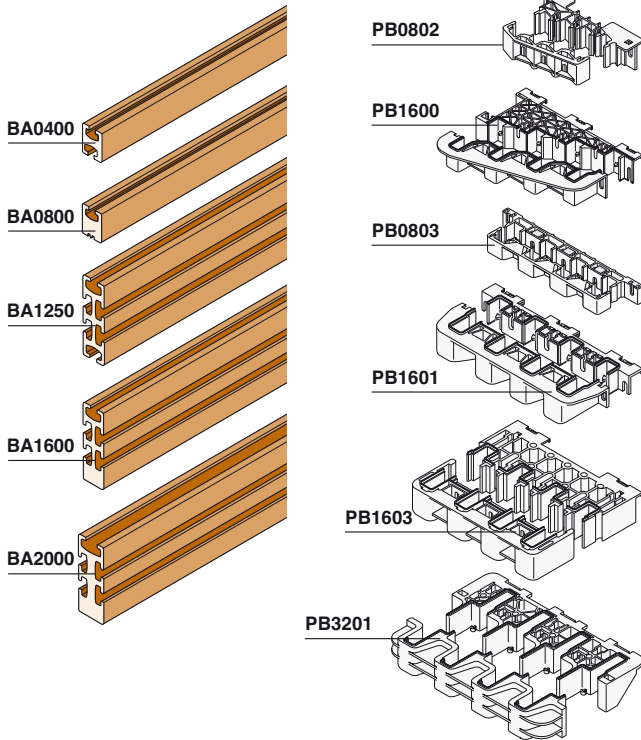

Distribution busbar with shaped section

Code	Description	Dimensions W (mm)
BA0400	Busbar In=400A	1730
BA0800	Busbar In=800A	1730
BA1250	Busbar In=1250A	1730
BA1600	Busbar In=1600A	1730
BA2000	Busbar In=2000A (1 busbar per phase) In = 3200A (2 busbars per phase)	1730

Busbar holder for shaped section

Code	Description
Scaled	
PB0802	Scaled busbar holder In=800A - 35kA
PB1600	Scaled busbar holder up to In=1600A - 75kA
Linear	
PB0803	Linear busbar holder In=800A - 35kA
PB1601	Linear busbar holder up to In=1600A - 75kA
PB1603	Linear busbar holder up to In=1600A - 65kA
PB3201	Linear busbar holder up to In=3200A - 100kA (1-2 busbars per phase)

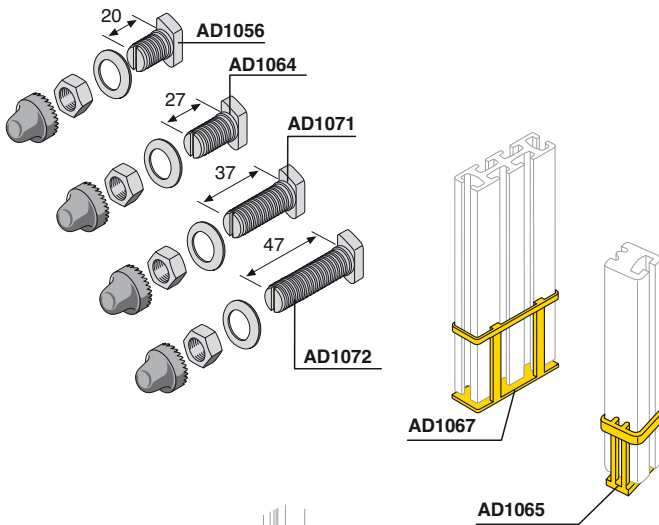

Hammer seal screws for busbars with shaped section

Code	Description
AD1056	N°12 M8 hammer screws W=20mm for cable terminal
AD1064	N°12 M8 screws-W=27mm for flat busbars up to 10mm, complete with screw-covering cap
AD1071	N°12 M8 screws-W=37mm for flat busbars up to 20mm, complete with screw-covering cap
AD1072	N°12 M8 screws-W=47mm for flat busbars up to 20mm, complete with screw-covering cap

Resting bases with shaped section

Code	Description
AD1065	N°4 resting bases for 400/800A busbars
AD1067	N°4 resting bases for 1250/1600A busbars

Adapters for busbars with shaped section

Code	Description
AD1066	N°4 adapters for In=400/800A busbars with busbar holder (PB1600-PB1601-PB1603)

1STC802757F0001

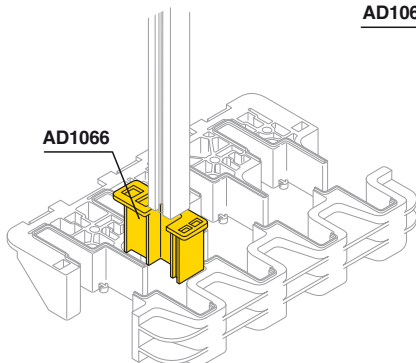

ArTu K

Distribution system

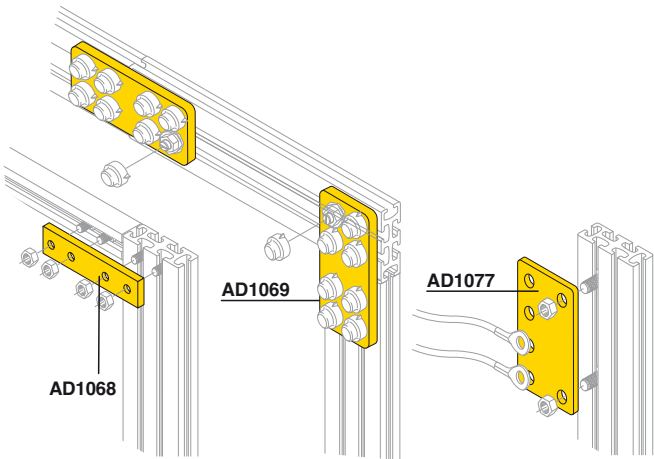

Joints for busbars with shaped section

Code	Description
AD1068	N ⁴ joints for 800A busbars with shaped section (with 800/1250/1600A busbars)
AD1069	N ⁴ joints for 1250/1600A busbars with shaped section (with 1250/1600A busbars)
AD1063	N ⁴ joints for connecting busbars with shaped section (with rectangular pre-drilled busbars pitch 25mm)
AD1078	N ⁴ joints complete with screws for connecting busbars with shaped section up to 3200A (with busbars with shaped section up to 1600A)
AD1073	N ⁴ joints complete with screws for connecting 3200A busbars with shaped section
AD1077	N ⁴ copper 400A branch joints

Selection of the connection joint and busbar holder compatibility

Horizontal busbars

		Horizontal busbars		
		Bars with shaped section		Flat busbars
		PB3201 (3200A)	PB1601 (1250/1600A)	BP3200 (3200A)
Vertical busbars	Bars with shaped section	Busbar holder		
		PB3201 (3200A)	2x AD1069 ⁽¹⁾ 1x AD1073 ⁽²⁾	
		PB1601 (1250/1600A)	AD1078	AD1069
		PB1603 (1250/1600A)		AD1069
		PB1600 (1250/1600A)	AD1069	
		PB1601 (≤800A)	AD1078	AD1068
		PB1603 (≤800A)		AD1068

Joints valid for "T" and "L" branches.

⁽¹⁾ Only "L" branch

⁽²⁾ Only "T" branch

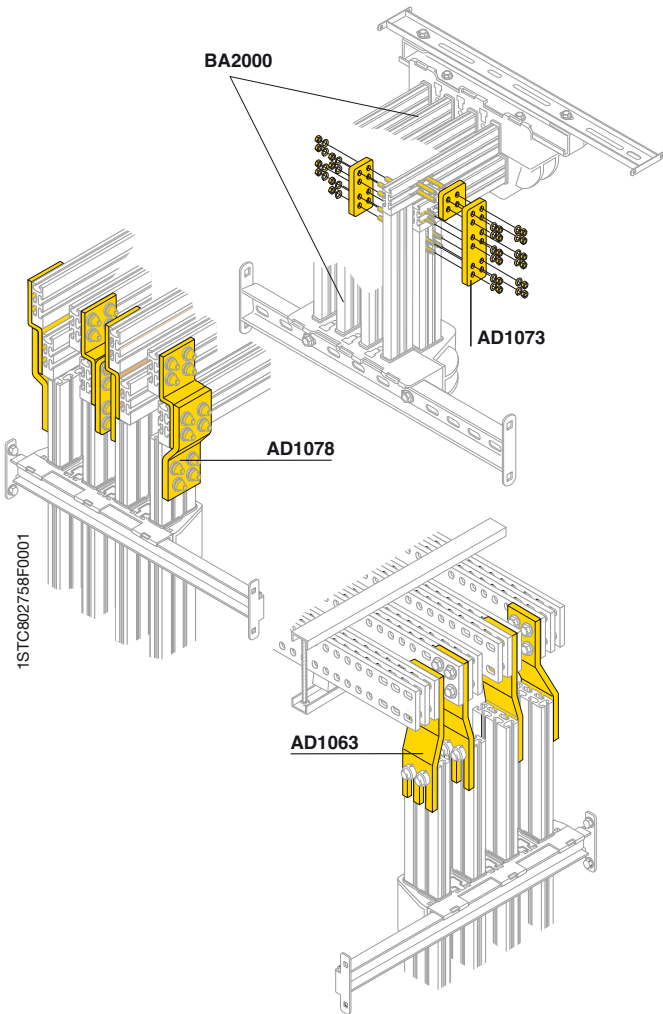

1STC802758F0001

ArTu K

Distribution system

Pic.1

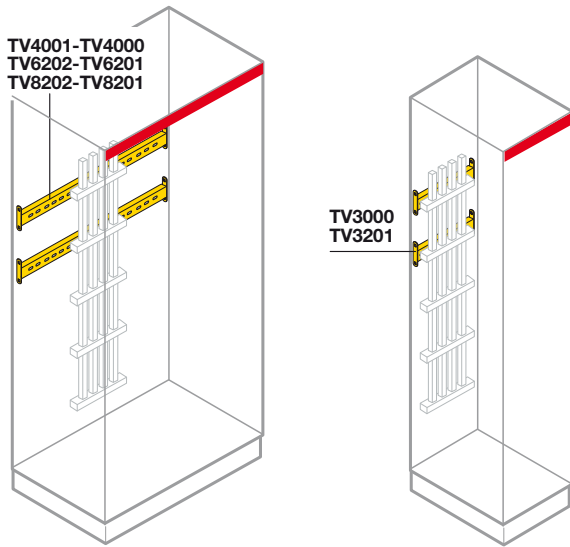

Fixing crosspieces for busbars with shaped section

Pic. 1
Busbars vertically on back of structure

Code			Description
12 DIN mod	24 DIN mod	36 DIN mod	
W=390mm	W=600mm	W=800mm	
TV4001			N°2 crosspieces structure for PB0803/PB0802
	TV6202	TV8202	N°2 crosspieces structure for PB0803
TV4000			N°2 crosspieces structure for PB1600/PB1601/PB1603
	TV6201	TV8201	N°2 crosspieces structure for PB1601/PB1603

Busbars vertically on back of external/internal cable container

Code		Description
Int. cable container	Ext cable container	
W=200mm	W=300mm	
	TV3201	N°2 crosspieces for PB0802/PB1600
TV3000		N°2 crosspieces for PB0802

Pic. 2

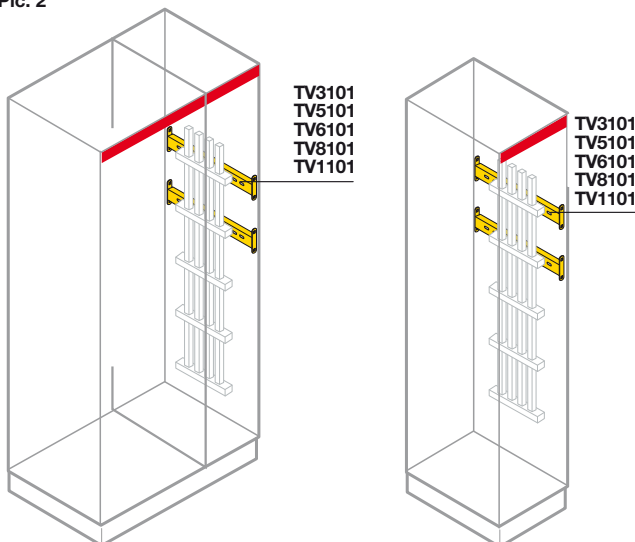

Pic. 2
Vertical busbars on side of the internal/external cable container

Code					Description
D=225mm	D=300mm	D=500mm	D=700mm	D=900mm	
TV3101	TV5101				N°2 crosspieces internal cable container PB0802
		TV6101 ⁽¹⁾			N°2 Internal/external cable container crosspieces for PB1600/PB1601/PB1603
			TV8101	TV1101	N°2 Internal/external cable container crosspieces for PB1600/PB1601/PB1603/PB3201

⁽¹⁾ With PB1600 only in the additional cable container.

Pic. 3

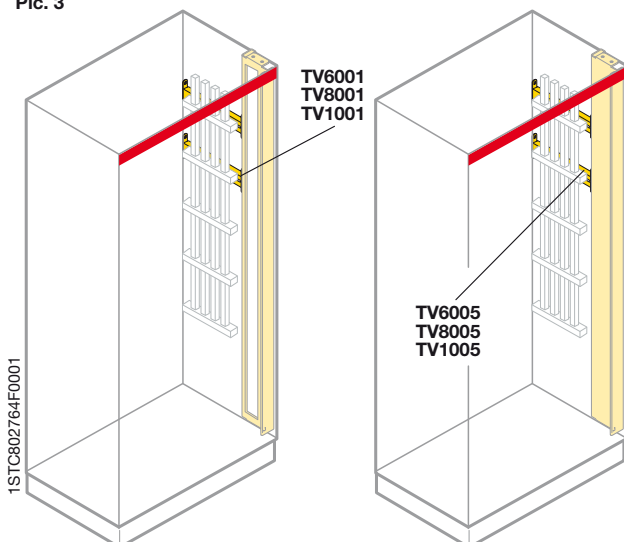

Pic. 3
Busbars vertically on side of structure

Code						Description
D=500mm		D=700mm		D=900mm		
open frame	closed frame	open frame	closed frame	open frame	closed frame	
TV6001	TV6005					N°2 crosspieces for PB01603
		TV8001	TV8005			N°2 crosspieces for PB1600/PB01601/PB1603/PB3201
				TV1001	TV1005	N°2 crosspieces for PB1600/PB01601/PB1603/PB3201

ArTu K

Distribution system

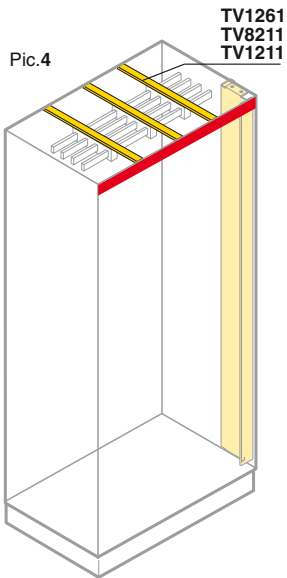

Pic. 4
Top horizontal busbars under the roof

Code			Description
D=500mm	D=700mm	D=900mm	
TV1261			N°2 crosspieces for PB1603
TV8211	TV1211		N°2 crosspieces for PB1601/PB1603/PB3201

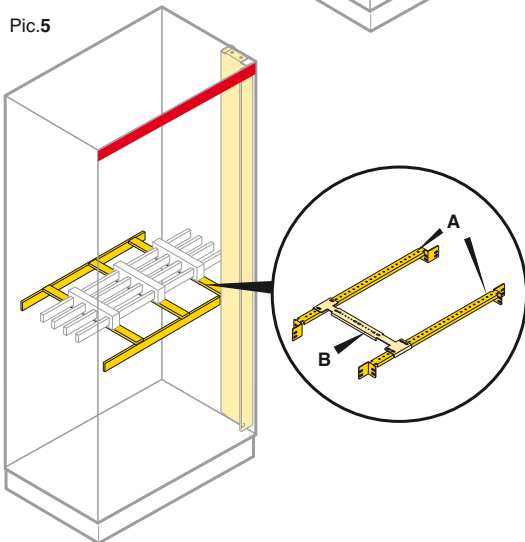

Pic. 5
Busbar horizontal at any height

Code A			Description
12 DIN mod	24 DIN mod	36 DIN mod	
W=390mm	W=600mm	W=800mm	
TV4221⁽²⁾			N°2 crosspieces for PB1601/PB1603
TV6221⁽²⁾	TV8221⁽²⁾		N°2 crosspieces for PB1601/PB1603/PB3201

Code B			Description
D=500mm	D=700mm	D=900mm	
TV6011			N°2 crosspieces for PB1603
TV8011	TV1011		N°2 crosspieces for PB1601/PB1603/PB3201

⁽²⁾ With structures W=800mm with internal cable container, use a TV6221 crosspiece plus a TV8221 crosspiece as in Pic. 1 or two TV6221 crosspieces with the intermediate upright SK1880 or SK2080, as in Pic. 2.

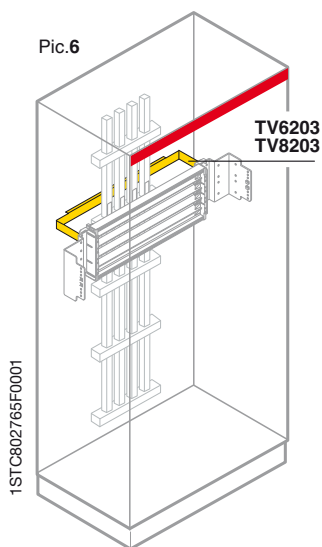
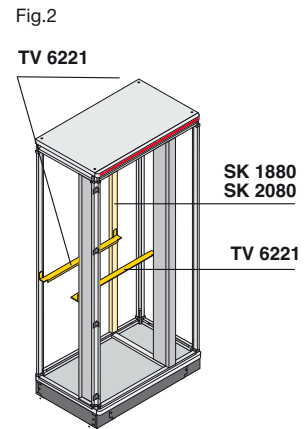
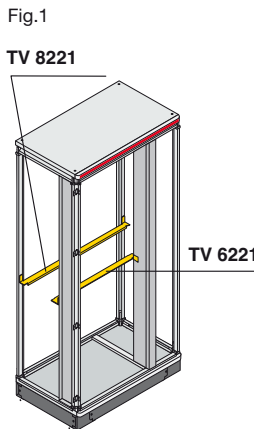

Pic.6
Connection to the Unifix H system

Code		Description
24 DIN mod	36 DIN mod	
W=600mm	W=800mm	
TV6203	TV8203	N°2 crosspieces for PB0803

ArTu K

Distribution system

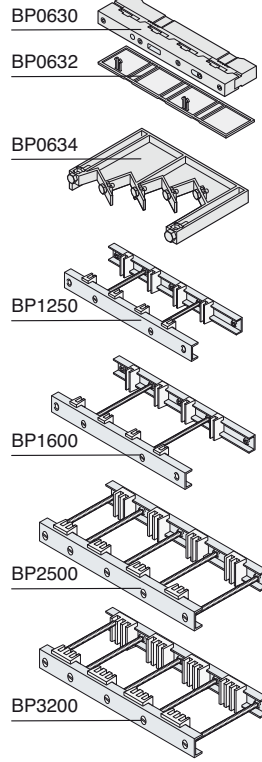
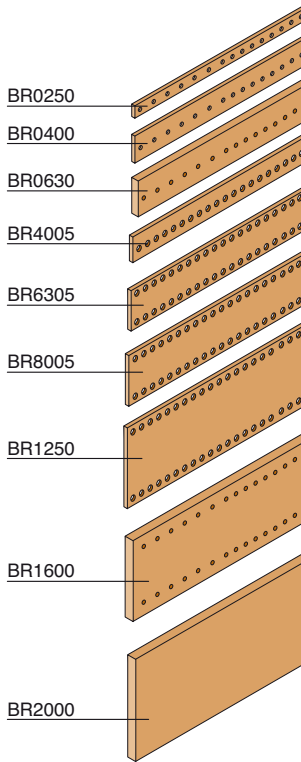

Flat busbars

Code	Description	Dimensions W (mm)
BR0250	N°2 busbars In=250A, section 15x5mm	1750
BR0400	N°2 busbars In=400A, section 25x5mm	1750
BR0630	N°2 busbars In=630A, section 30x10mm	1750
BR4005	N°2 busbars In=400A, section 32x5mm	1750
BR6305	N°2 busbars In=630A, section 50x5mm	1750
BR8005	N°2 busbars In=800A, section 63x5mm	1750
BR1250	N°2 busbars In=1250A, section 100x5mm	1750
BR1600	N°2 busbars In=1600A, section 100x10mm	1750
BR2000	N°2 busbars In=2000A, section 120x10mm	1750

Busbar holders

Code	Description
BP0630	N°2 linear busbar holders In=630A - 32kA
BP0632	N°2 terminal covers for linear busbar holders BP0630
BP0634	N°2 scaled busbar holders In=630A - 23kA
BP1250	N°2 busbar holders for busbars 5mm thick
BP1600	N°2 busbar holders for busbars 10mm thick
BP2500	N°2 busbar holders for 2 busbars per phase 10mm thick
BP3200	N°2 busbar holders for 3 busbars per phase 10mm thick

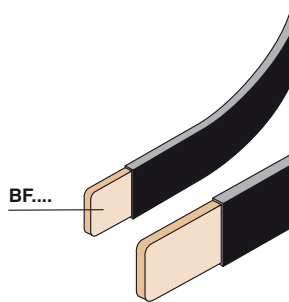

Flexible busbars

Flexible busbars insulated in self-extinguishing material

Code	Description	In (A)	Dimensions W (mm)
BF1602	N°2 busbar section 20x3mm	250	2000
BF2502	N°2 busbar section 20x5mm	400	2000
BF4002	N°2 busbar section 24x6mm	500	2000
BF4012 ⁽¹⁾	N°2 busbar section 32x5mm	630	2000
BF6302	N°2 busbar section 40x8mm	1000	2000
BF8002	N°2 busbar section 50x10mm	1250	2000

⁽¹⁾ Only for circuit-breakers with front extended terminals or rear terminals.

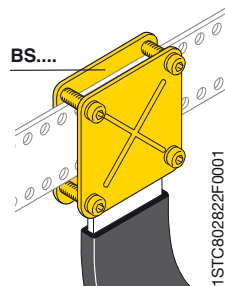

Busbar clamps

Kit for tightening the flexible busbars onto the rigid busbars, without the need to drill the flexible busbars.

Code	Description
BS3250	N°4 busbar tightening plates for busbars H=40mm
BS5050	N°4 busbar tightening plates for busbars H=50mm
BS6350	N°4 busbar tightening plates for busbars H=63mm

ArTu K

Distribution system

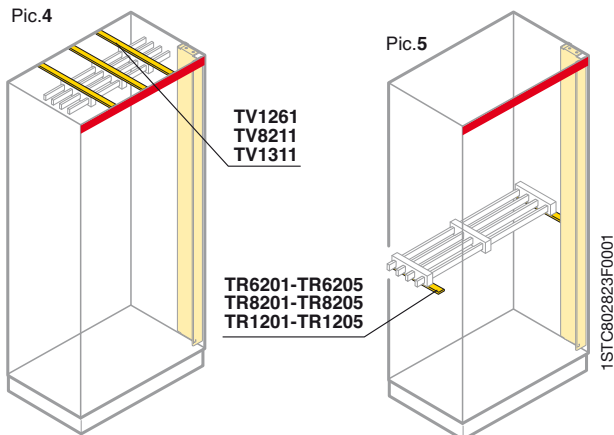
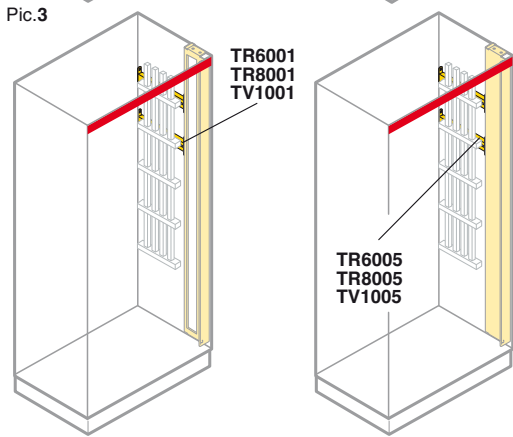
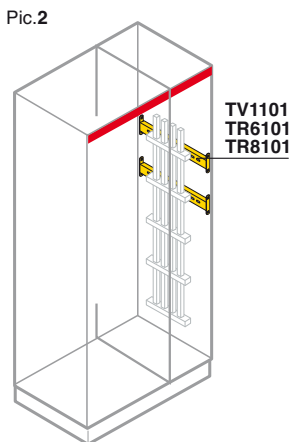
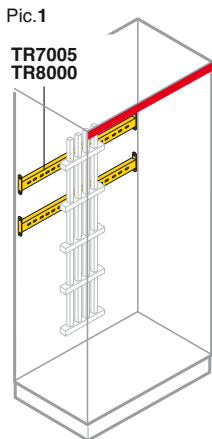

Fixing crosspieces for flat busbars

Pic.1
Busbars vertically on back of structure

Code		Description
24 DIN mod W=600mm	36 DIN mod W=800mm	
TR7005	TR8000	N°2 crosspieces for BP1250/BP1600/BP2500/BP3200

Pic. 2
Busbars vertically on side of internal/additional cable container

Code		Description
D=500mm	D=700mm	D=900mm
TR6101	TR8101	TV1101
N°2 crosspieces on side of cable container		

Busbar in horizontally on external cable container

Code		Description
D=500mm	D=700mm	
TR6301	TR8301	N°2 Crosspieces for horizontal busbars in the cable container

Pic. 3
Busbars vertically on side of structure

Code		Description			
D=500mm	D=700mm	D=900mm			
open frame	closed frame	open frame	closed frame	open frame	closed frame
TR6001	TR6005	TR8001	TR8005	TV1001	TV1005
N°2 crosspieces on side of structure					

Pic. 4
Busbars horizontally at top of structure

Code		Description
D=500mm	D=700mm	D=900mm
TV1261	TV8211	TV1211
N°2 horizontal crosspieces		
TV1311 (400A)		

Pic. 5
Busbars horizontally at any height in the structure

Code		Description
D=500mm	D=700mm	D=900mm
open frame	closed frame	open frame
open frame	closed frame	open frame
open frame	closed frame	open frame
TR6201	TR6205	N°2 crosspieces for BP1250/BP1600
TR8201		TR8205
TR1201		TR1205
N°2 crosspieces for BP1250/BP1600		
BP2500/BP3200		

ArTu K

Distribution system

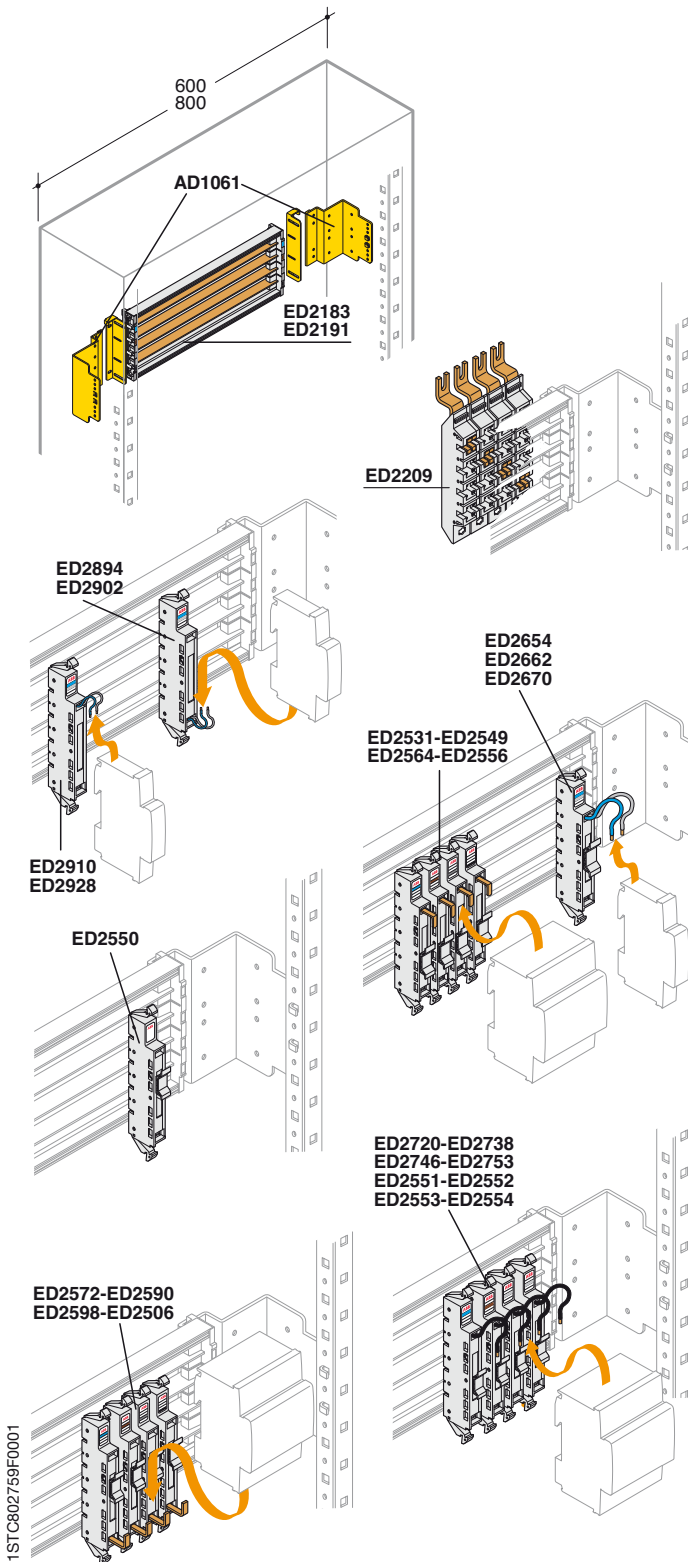

Unifix H

Frames for Tmax

Code	Description	Dimensions W (mm)
ED2183	Frame with 24 DIN module busbars	600
ED2191	Frame with 36 DIN module busbars	800
AD1061	N°2 fixing brackets onto structure for ED2183 o ED2091	

Feeder modules

Code	Description
ED2209	4P 400A feeder module (for ED2183-ED2191)

Basic modules I_n 16A

Code	Description
ED2894	Basic module for auxiliary CBs DIN L1-N top 16A
ED2902	Basic module for auxiliary CBs DIN L1-L2 top 16A
ED2910	Basic module for auxiliary CBs DIN L1-N bottom 16A
ED2928	Basic module for auxiliary CBs DIN L1-L2 bottom 16A

Basic modules I_n 40A

Code	Description
ED2654	Basic module L1/Neutral top 40A
ED2662	Basic module L2/Neutral top 40A
ED2670	Basic module L3/Neutral top 40A

Basic modules I_n 63A

Code	Description
ED2531	Basic module L1 top 63A
ED2549	Basic module L2 top 63A
ED2556	Basic module L3 top 63A
ED2564	Basic module Neutral top 63A
ED2572	Basic module L1 top 63A
ED2590	Basic module L2 top 63A
ED2598	Basic module L3 top 63A
ED2606	Basic module Neutral top 63A

Basic modules I_n 100A

Code	Description
ED2720	Basic module with cable L1 top 100A
ED2738	Basic module with cable L2 top 100A
ED2746	Basic module with cable L3 top 100A
ED2753	Basic module with cable Neutral top 100A

Basic modules ≤I_n 40A S800

Code	Description
ED2557	Basic module L1 top ≤40A
ED2558	Basic module L2 top ≤40A
ED2559	Basic module L3 top ≤40A
ED2560	Basic module Neutral top ≤40A

Basic modules I_n 125A S800

Code	Description
ED2551	Basic module L1 top 125A
ED2552	Basic module L2 top 125A
ED2553	Basic module L3 top 125A
ED2554	Basic module Neutral top 125A
ED2550	Basic module false pole W=27mm

ArTu K

Distribution system

ED2217-ED2225
ED2233-ED2241
ED2258-ED2266
ED2274-ED2282
ED2332-ED2340
ED2357-ED2365

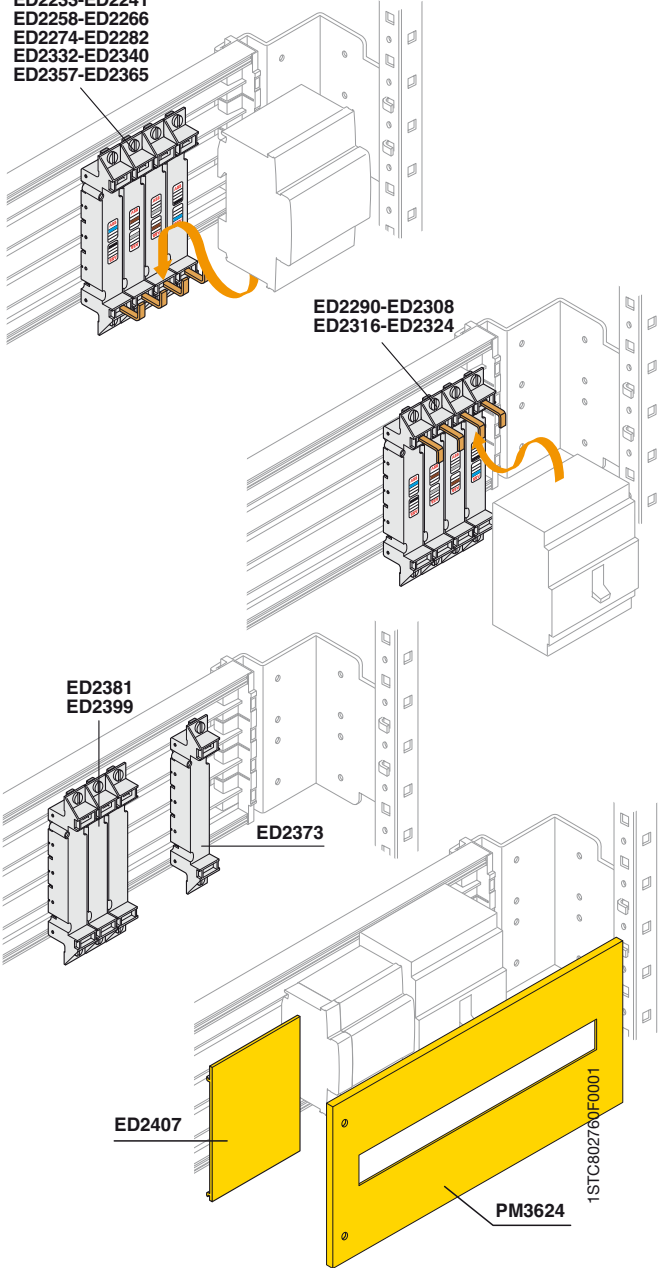

Unifix H

Basic modules I_n 160A Tmax T1

Code	Description
ED2217	Basic module L1 top L2 bottom
ED2225	Basic module L2 top L1 bottom
ED2233	Basic module L3 top Neutral bottom
ED2241	Basic module Neutral top L3 bottom
ED2373	Basic module false pole for residual current release RC221
ED2381	Basic module false pole for solenoid operator

Basic modules I_n 160A Tmax T2

Code	Description
ED2258	Basic module L1 top L2 bottom
ED2266	Basic module L2 top L1 bottom
ED2274	Basic module L3 top N bottom
ED2282	Basic module N top L3 bottom
ED2373	Basic module false pole for residual current release RC221
ED2399	Basic module false pole for solenoid operator

Basic modules I_n 250A Tmax T3

Code	Description
ED2290	Basic module L1 top
ED2308	Basic module L2 top
ED2316	Basic module L3 top
ED2324	Basic module N top
ED2332	Basic module L1 bottom
ED2340	Basic module L2 bottom
ED2357	Basic module L3 bottom
ED2365	Basic module N bottom
ED2373	Basic module false pole for residual current release RC221

Accessories

Code	Description
ED2845	Basic module false pole for DDA W=17.5mm
ED2852	Basic module false pole for modular MDRC
ED2407	N°2 IP20 covers (for ED2183-ED2191) W=173mm (10 DIN modules)
ED2936	N°6 wiring duct supports 40x60mm (modular apparatus only)
AD1061	ArTu M Kit for ED2183 and ED2191
PM3624	Modular front panel 300x600mm (HxW)
PM3836	Modular front panel 300x800mm (HxW)

Spare parts

Code	Description
ED0001	N°10 terminal covers T1
ED0002	N°10 terminal covers T2
ED0003	N°10 terminal covers T3
ED0004	N°10 terminal covers S200/F200

1STC802760F0001

ArTu K

Distribution system

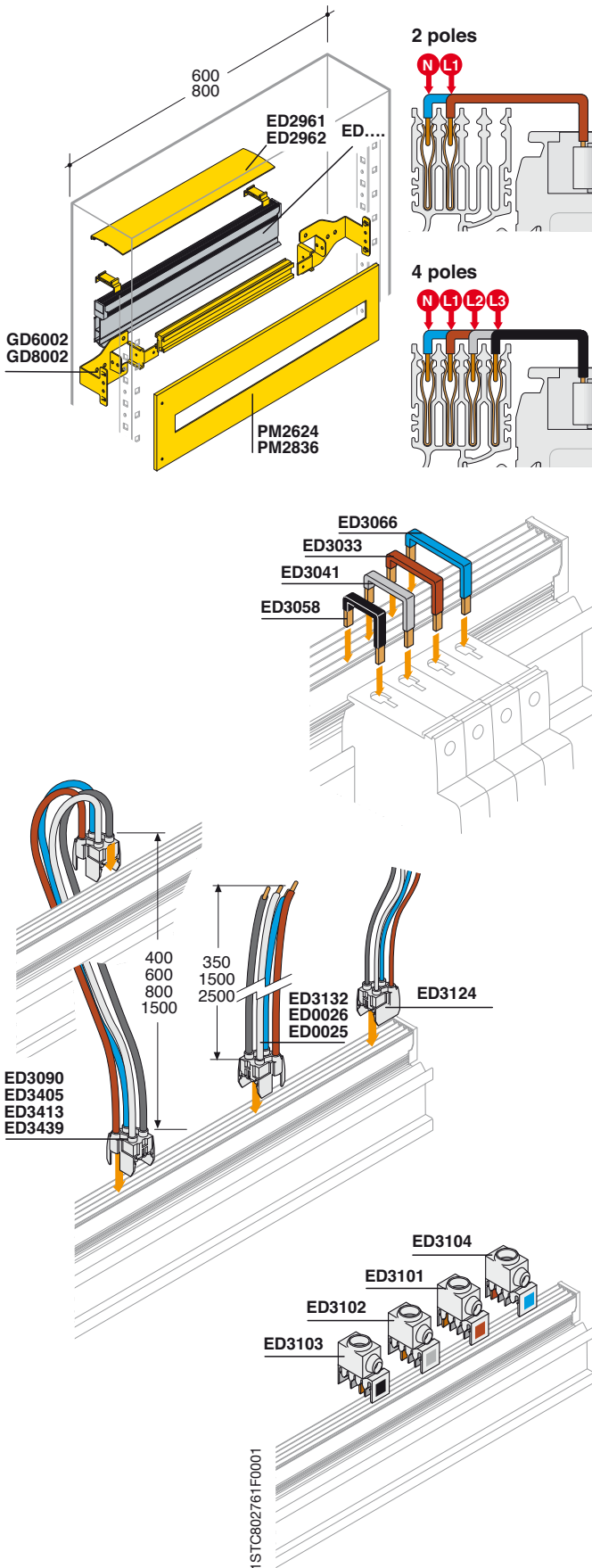

Unifix L

2-pole busbars

Code	Description	Dimensions W (mm)
ED2985	100A 2P 8 module busbar	200
ED2993	100A 2P 12 module busbar	400
ED3009	100A 2P 18 module busbar	450
ED3017	100A 2P 24 module busbar	600
ED3025	100A 2P 36 module busbar	800

4-pole busbars

Code	Description	Dimensions W (mm)
ED2944	100A 4P 12 module busbar	400
ED2951	100A 4P 18 module busbar	450
ED2969	100A 4P 24 module busbar	600
ED2977	100A 4P 36 module busbar	800

Connections for various apparatus

Code	Description
ED3108	Connection with 2 conductors L/N 16A
ED3116	Connection with 3 conductors L1/L2/L3 16A
ED3124	Connection with 4 conductors L1/L2/L3/N 16A single phase
ED3355	Connection with 2 conductors L1/N 40A
ED3363	Connection with 3 conductors L1/L2/L3 40A
ED3371	Connection with 4 conductors L1/L2/L3/N 40A

Connections for apparatus

Code	Description
ED3272	N°10 connections L1-N 40 A
ED3280	N°10 connections L2-N 40 A
ED3298	N°10 connections L3-N 40 A
ED3033	N°10 connections L 1 100A
ED3041	N°10 connections L 2 100A
ED3058	N°10 connections L 3 100A
ED3066	N°10 connections N 100A
ED3132	Feeder with 4P 100A cable (W=350mm)
ED0026	Feeder with 4P 100A cable (W=1500mm)
ED0025	Feeder with 4P 100A cable (W=2500mm)

Power supply modules with cable

Code	Description	Dimensions W (mm)
ED3082	Parallel module 2P 100A with cable	600
ED3405	Parallel module 4P 100A with cable	400
ED3090	Parallel module 4P 100A with cable	600
ED3413	Parallel module 4P 100A with cable	800
ED3439	Parallel module 4P 100A with cable	1500

Power supply modules without cable in 100A

Code	Description
ED3101	N°10 single-pole power supply terminals L1
ED3102	N°10 single-pole power supply terminals L2
ED3103	N°10 single-pole power supply terminals L3
ED3104	N°10 single-pole power supply terminals N

Accessories

Code	Description	Dimensions W (mm)
ED2961	N°10 busbar covers	600
ED2962	N°2 busbar covers	800
GD4002	DIN rail Kit and supports	390
GD6002	DIN rail Kit and supports	600
GD8002	DIN rail Kit and supports	800
PM2424	Modular front panel 200x390mm (HxW)	
PM2624	Modular front panel 200x600mm (HxW)	
PM2836	Modular front panel 200x800mm (HxW)	

ArTu K

Accessories

Structure side-by-side kit

Code	Description
AD1014	Kit for placing structures H=1600-1800-2000mm side by side laterally

The ArTu K switchgear can be placed side by side both laterally and at the rear. The IP65 side-by-side kit consists of a set of supports and a gasket for keeping the degree of protection. In the IP31 version, in addition to the AD1014 kit, order the double finishing section (see page 9/54).

Lifting eyebolts

Code	Description
AA9610	N° 4 steel M12 lifting eyebolts

These allow cabled switchgear to be lifted. They are made of steel treated with white passivated galvanisation.

Lifting reinforcements

Code	Description
SA1350	N° 2 lifting reinforcements for side-by-side structures

These allow handling of several ArTu K switchgear placed side by side.

Brackets for fixing to the wall

Code	Description
AD1808	N° 2 brackets for fixing to the wall

These allow ArTu K switchgear to be fixed to the wall.

Additional base strip H=100mm Base strip for structure

Code	Description	Dimensions D (mm)		
12 DIN mod 24 DIN mod 36 DIN mod				
W=390mm W=600mm W=800mm				
	ZD2624	ZD2824	N°4 base strip + n°4 flanges	150
ZD2440	ZD2640	ZD2840	N°4 base strip + n°4 flanges	225
ZD2450	ZD2650	ZD2850	N°4 base strip + n°4 flanges	300
ZD2460	ZD2660	ZD2860	N°4 base strip + n°4 flanges	500
ZD2480	ZD2680	ZD2880	N°4 base strip + n°4 flanges	700
ZD4010	ZD6010	ZD8010	N°4 base strip + n°4 flanges	900

Base strip for cable container external

Code	Description	Dimensions D (mm)
W=300mm		
ZD2324	N°4 base strip + n°4 flanges	150
ZD2340	N°4 base strip + n°4 flanges	225
ZD2350	N°4 base strip + n°4 flanges	300
ZD2361	N°4 base strip + n°4 flanges	500
ZD2381	N°4 base strip + n°4 flanges	700

Code	Description
AZ4000	N°4 base strip angle pieces H=100mm

To make a 200mm high base strip, order a H=100mm kit, which includes four additional angle pieces and four additional flanges.

Reinforced base strip H=100mm

Code	Description				
Additional cab. cont.					
12 DIN mod 24 DIN mod 36 DIN mod	ZR4000	ZR6000	ZR8000	ZR3000	Front and rear profile
W=390mm W=600mm W=800mm W=300mm					

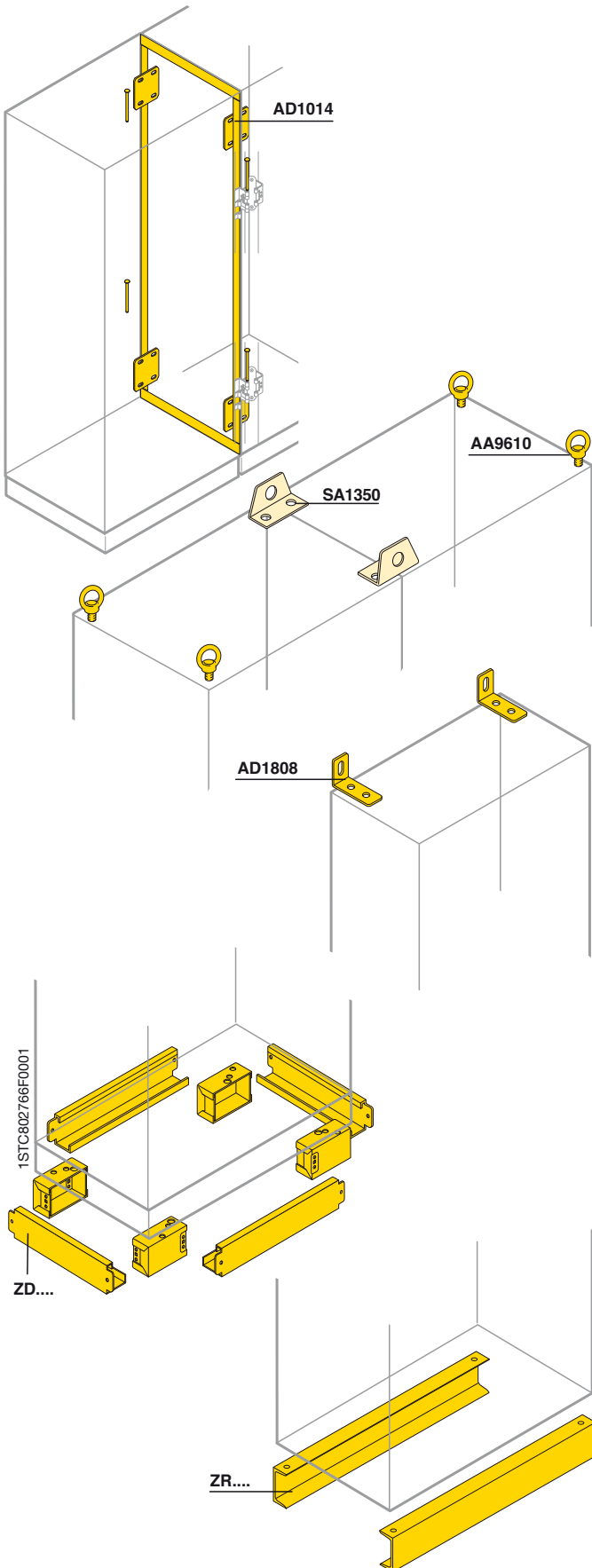

ArTu K Accessories

Pic.1

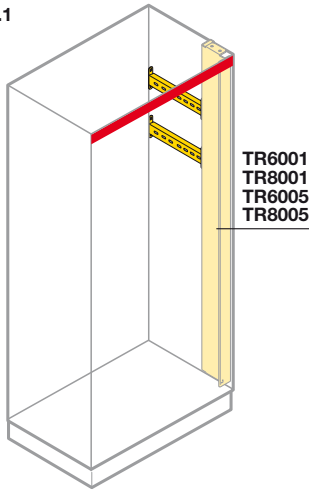

Pic.2

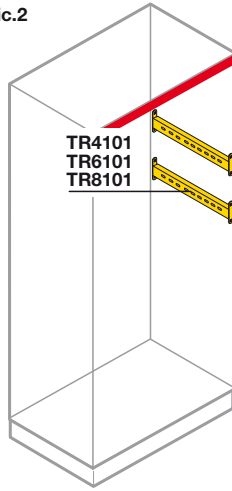

Pic.3

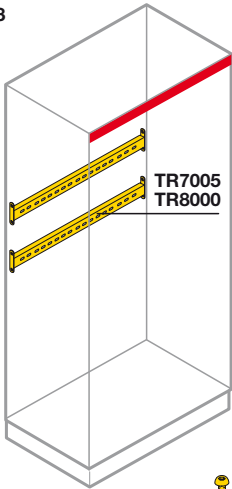

Pic.4

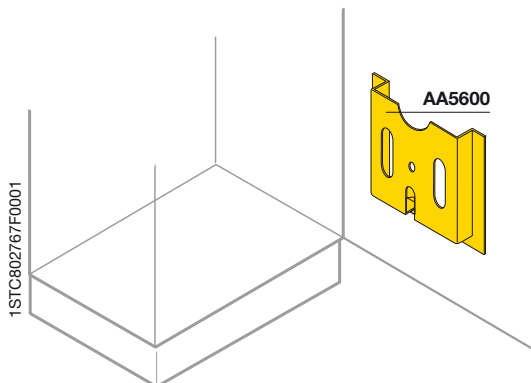
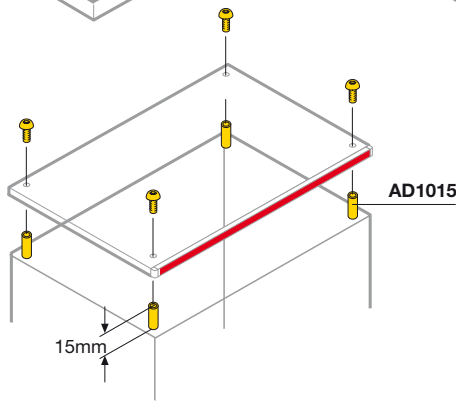
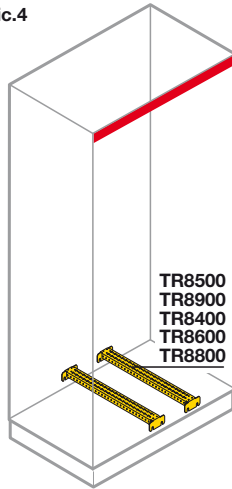

Code	Mounting Pic.	Description
D=500mm D=700mm		
TR6001 TR8001	1	N°2 side crosspieces

Segregated switchboards

Code	Mounting Pic.	Description
D=500mm D=700mm		
TR6005 TR8005	1	N°2 side crosspieces

Segregated/non segregated switchboards

Code	Mounting Pic.	Description
D=225mm D=300mm D=500mm D=700mm		
TR4101 TV5101 TR6101 TR8101	2	N°2 side crosspieces

Code	Mounting Pic.	Description
24 mod DIN 36 mod DIN W=600mm W=800mm		
TR7005 TR8000	3	N°2 rear crosspieces

Can be mounted on the structure to anchor cables or to mount accessories. The crosspieces for accessories can be mounted on the side, on the rear or in the cable container of the structure.

Reinforcement crosspieces

Code	Mounting Pic.	Description
D=225mm D=300mm D=500mm D=700mm D=900mm		
TR8400 TR8500 TR8600 TR8800 TR8900	4	N°2 Reinforcement crosspieces for structures

Recommended for installation of fuse bases or transformers.

Roof ventilation kit

Code	Description
AD1015	Roof ventilation kit

Allows the roof of the cabinet to be raised thereby increasing ventilation and therefore the power which can be dissipated. The degree of protection is IP20. The ventilation kit must not be mounted if the cabinet has to be lifted using the eyebolts. In this case, the kit must be mounted when installation has been completed.

Diagram pocket holder

Code	Description
AA5600	Plastic diagram pocket holder

The diagram pocket holder (made of RAL 2004 colour plastic, dim. HxL 237x265mm type A4) is applied to the inside of doors/blind panels of suitable size using the adhesive provided.

ArTu K

Accessories

Supports for terminal boxes

Structure

Code	Description
AD1041	N° 2 supports for horizontal 45° angled terminal box for ArTu K
AD1054	N° 2 supports for horizontal terminal box for ArTu K

Additional cable container

Code	Description
AD1055	N° 4 supports for vertical terminal box in internal/additional ArTu K cable container

Angled supports for terminal boxes and earthing busbars

Code	Description
EV1110	N°50 angled supports 1 row of terminals
EV2110	N°10 angled supports 1 row of terminals
EV1111	N°10 angled supports double row of terminals
EV1112	N°50 angled supports 1 row of terminals + earth
EV2112	N°10 angled supports 1 row of terminals + earth
EV1113	N°2 angled supports 1 row of terminals + earth

Insulators and copper busbars for neutral/earthing

Code	Description	Dimensions W (mm)
EV1119	N°2 busbars 20x5 mm drilled and threaded M6	2000
EV1120	N°2 busbars 25x5 mm drilled and threaded M6	2000
EV1121	N°2 busbars 50x5 mm drilled and threaded M6	2000
EV1122	N°50 hexagonal insulators 30x30mm M6	
EV1123	N°50 hexagonal insulators 30x30mm M8	
EV1124	N°50 hexagonal insulators 36x50mm M6	
EV1125	N°50 hexagonal insulators 36x50mm M8	

Sections for accessories

Code	Description	Dimensions W (mm)
TS4011	N°2 sections EN50024 C30	2000
TS4012	N°2 sections EN50035 G32	2000
TS4013	N°2 DIN sections EN50022	2000
TS4000	N°2 cable rails	600
TS4001	N°2 cable rails	800
TS4002	N°2 cable rails	1000
TS4003	N°2 cable rails	1200

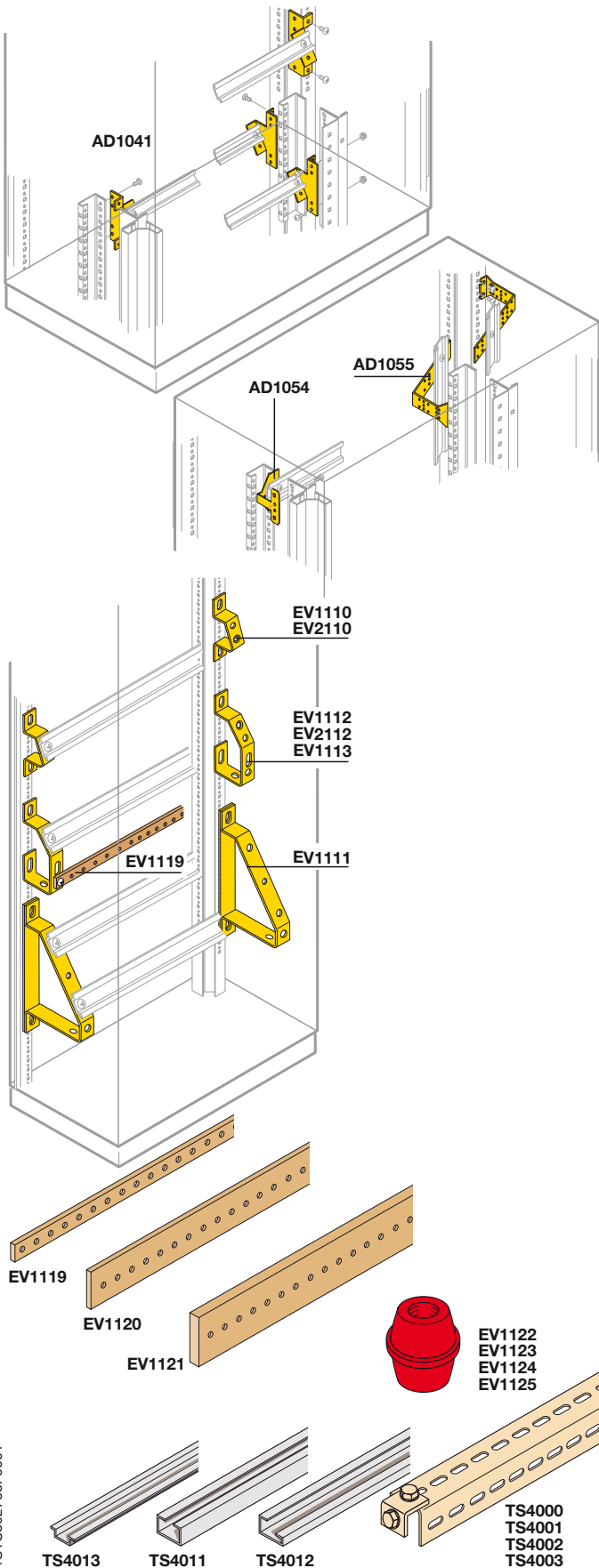

ArTu K Accessories

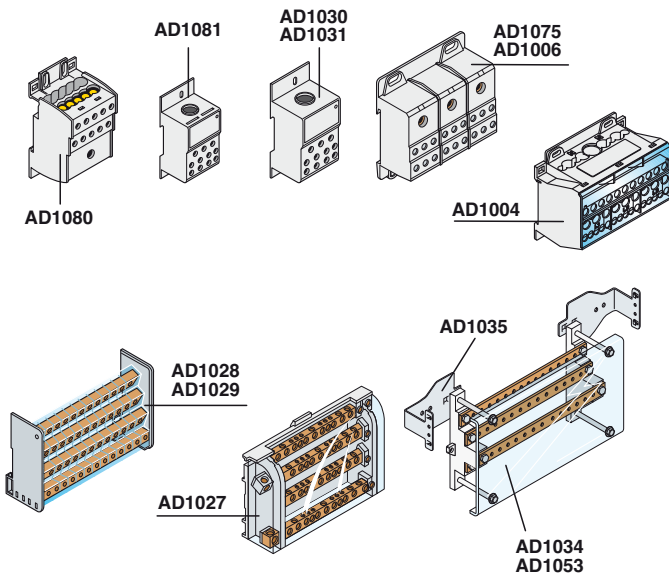

1STC802762F0001

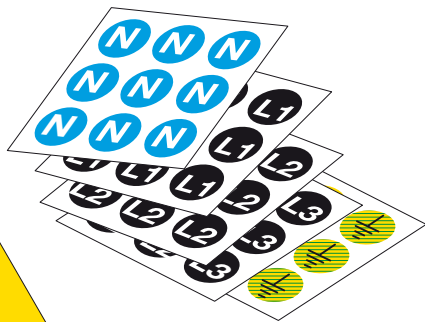
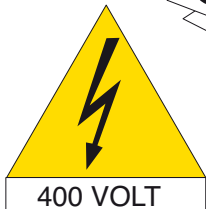

Dividers

Code		Description		
Single-pole	Three-pole	Four-pole		
AD1076 ⁽¹⁾	AD1075	AD1004	Modular 125A	
AD1080 ⁽²⁾			AD1028	Modular 125A-medium-89x93x48 (LxWxH)
			AD1029	Modular 125A-large-126x93x48 (LxWxH)
AD1007 ⁽¹⁾	AD1006	AD1027	Modular 160A	
AD1081 ⁽²⁾			Modular 250A	
AD1030			AD1034	Horizontal 250A for structures W=600mm
			AD1053	Horizontal 250A for structures W=800mm
			AD1031	Modular 400A

⁽¹⁾ 10 outputs - ⁽²⁾ 6 outputs

Mounting accessories

Code	Description
AD1035	Supports for fixing to the structure for AD1034 and AD1053
AD1083	Connection accessory between two AD1080

Marking

Code	Description
EV1150	N°490 adhesive labels ø12mm symbol N
EV1151	N°490 adhesive labels ø12mm symbol L1
EV1152	N°490 adhesive labels ø12mm symbol L2
EV1153	N°490 adhesive labels ø12mm symbol L3
EV1154	N°490 adhesive labels ø12mm symbol T
EV1155	N°10 triangular adhesive labels 125mm with 400V lightning arrow symbol
EV1156	N°100 triangular adhesive labels 50mm with lightning arrow symbol

Brackets for anchoring cables

Adjustable cable blocking bracket can be mounted on sections with 10mm slot EV1050.

Code	Description
EV1090	N°10 cable blocking brackets min÷max ø 9÷16mm
EV1091	N°10 cable blocking brackets min÷max ø 16÷30mm
EV1092	N°5 cable blocking brackets min÷max ø 30÷48mm
EV1093	N°5 cable blocking brackets min÷max ø 48÷72mm

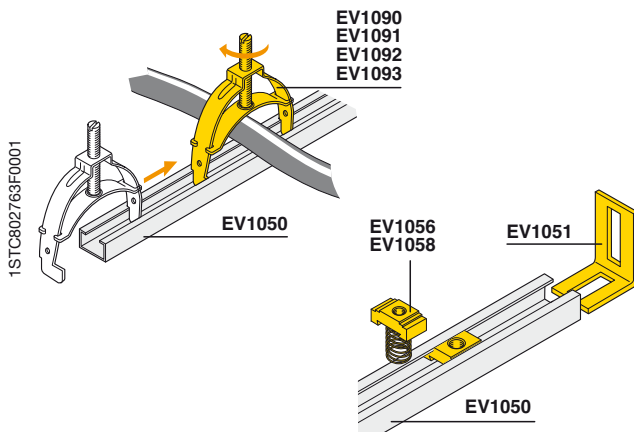

1STC802763F0001

Aluminium sliding guides for universal uses

Code	Description
EV1050	N°10 aluminium supporting sections 30x15 - W=2000mm
EV1051	N°25 fixing brackets for EV1050
EV1056	N°100 aluminium M6 nuts for EV1050
EV1058	N°100 aluminium M8 nuts for EV1050

ArTu K

Accessories

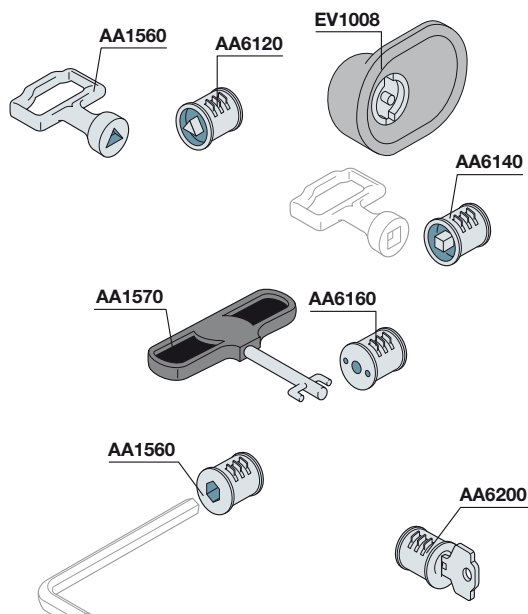

Inserts and keys

Code	Description
Cable container	
EV1008	Box+ Yale insert (without tab)
EV1036	Insert + Yale key for EV1008
EV1037	Ronis 455 insert + key for EV1008
EV1039	3mm double-tab insert + key for EV1008
Floor-mounted structures	
AA6100	Double-tab insert
AD1058	Double-tab Zn+Al+Mg alloy key
AA6200	Yale insert + key
AA6120	Male 6.4 triangular insert on ø 7.6
AA1560	Triangular key
AA6140	Male 7square type insert; key not available
AA6180	Hexagonal 8 type insert embedded; key not available
AA6160	FIST type insert (FIAT)
AA1570	Fiat key
AA8004	Ronis E739 insert + key

Accessories

Code	Description
AD1001	Internal finishing tape for IP31 Ral 7035 colour
AD1036	N°20 cage nuts
AD1033	N°50 three-lobed M6 spare screws
VB7035	RAL 7035 colour spray paint for touching up (400 ml spray can)

Spare parts

Code	Description
AD1090	N°10 hinges + screws for panels (spare part ACP468)
AD1091	N°10 plug + door key kits (spare part APT002)
AD1092	N°5 FP fixing accessories H=1800/2000mm (spare part A210)
CA1600	Chimes for door H=1600mm (spare part)
CA1800	Chimes for door H=1800mm (spare part)
CA2000	Chimes for door H=2000mm (spare part)
AD1047	N°2 DIN rail fixing brackets for open frame (switchgear without segregation)
AD1048	N°2 DIN rail fixing brackets for closed frame (segregated switchgear)
AD1057	"ArTu Survival Kit" - Accessories and small items for spare parts
AD1070	N°10 ArTu handle covers
AD1022	ArTu handle complete with lock and cover
AZ4000	N°4 base strip angle pieces H=100mm

ArTu L-M-K

Kit which can be managed at time of offer

Kit for Isomax S1

Code	Description
KL1101	Kit for S1 horiz. fixed RC mod. not segreg. l=800mm K
KR1111	Kit for S1 horiz. fixed not segreg. man. rot. K
KS1100	Kit for S1 horiz. fixed RC mod. segreg. K
KS1101	Kit for S1 horiz. fixed RC mod. not segreg. K
KS1102	Kit for S1 horiz. fixed RC mod. not segreg. M
KS1110	Kit for S1 horiz. fixed segreg. K
KS1111	Kit for S1 horiz. fixed not segreg. K
KS1112	Kit for S1 horiz. fixed not segreg. 3P M
KS1115	Kit for S1 horiz. fixed segreg. 3P K
KS1116	Kit for S1 horiz. fixed not segreg. 3P K
KS1117	Kit for S1 horiz. fixed not segreg. M
KS1120	Kit for S1 horiz. plug-in segreg. K
KS1121	Kit for S1 horiz. plug-in not segreg. K
KS1125	Kit for S1 horiz. plug-in segreg. 3P K
KS1126	Kit for S1 horiz. plug-in not segreg. 3P K
KS1410	Kit for S1 4P horiz. fixed segreg. 200x400mm (hwx) K
KS1411	Kit for S1 4P horiz. fixed 200x400mm (hwx) K
KS1415	Kit for S1 3P horiz. fixed segreg. 200x400mm (hwx) K
KS1416	Kit for S1 3P horiz. fixed 200x400mm (hwx) K
KS1420	Kit for S1 4P horiz. plug-in segreg. 200x400mm (hwx) K
KS1421	Kit for S1 4P horiz. plug-in 200x400mm (hwx) K
KS1425	Kit for S1 3P horiz. plug-in segreg. 200x400mm (hwx) K
KS1426	Kit for S1 3P horiz. plug-in 200x400mm (hwx) K

Kit for Isomax S2

Code	Description
KL2101	Kit for S2 horiz. fixed RC mod. not segreg. l=800mm K
KL2102	Kit for S2 horiz. fixed RC mod. not segreg. l=800mm M
KR2111	Kit for S2 horiz. fixed not segreg. man. rot. K
KS2100	Kit for S2 horiz. fixed RC mod. segreg. K
KS2101	Kit for S2 horiz. fixed RC mod. not segreg. K
KS2102	Kit for S2 horiz. fixed RC mod. not segreg. M
KS2110	Kit for S2 horiz. fixed segreg. K
KS2111	Kit for S2 horiz. fixed not segreg. K
KS2112	Kit for S2 horiz. fixed not segreg. 3P M
KS2115	Kit for S2 horiz. fixed segreg. 3P K
KS2116	Kit for S2 horiz. fixed not segreg. 3P K
KS2117	Kit for S2 horiz. fixed not segreg. M
KS2120	Kit for S2 horiz. plug-in segreg. K
KS2121	Kit for S2 horiz. plug-in not segreg. K
KS2125	Kit for S2 horiz. plug-in segreg. 3P K
KS2126	Kit for S2 horiz. plug-in not segreg. 3P K
KS2410	Kit for S2 4P horiz. fixed segreg. 200x400mm (hwx) K
KS2411	Kit for S2 4P horiz. fixed 200x400mm (hwx) K
KS2415	Kit for S2 3P horiz. fixed segreg. 200x400mm (hwx) K
KS2416	Kit for S2 3P horiz. fixed 200x400mm (hwx) K
KS2420	Kit for S2 4P horiz. plug-in segreg. 200x400mm (hwx) K
KS2421	Kit for S2 4P horiz. plug-in 200x400mm (hwx) K
KS2425	Kit for S2 3P horiz. plug-in segreg. 200x400mm (hwx) K
KS2426	Kit for S2 3P horiz. plug-in 200x400mm (hwx) K

ArTu L-M-K

Kit which can be managed at time of offer

Kit for Isomax S3

Code	Description
KI3110	Kit for S3 fixed segreg. interlocked K
KI3111	Kit for S3 fixed-plug-in not segr. interlocked + access. K
KI3122	Kit for S3 plug-in segreg. inter. mot. K
KI3130	Kit for S3 withdrawable segreg. interlocked K
KI3131	Kit for S3 withdr. not segr interlocked + access. K
KI3132	Kit for S3 withdrawable segreg. interlocked mot. K
KL3101	Kit for S3 horiz. fixed RC mod. not segreg. l=800mm K
KL3102	Kit for S3 horiz. fixed RC mod. not segreg. l=800mm M
KL3111	Kit for S3 horiz. fixed not segreg. l=800mm K
KL3112	Kit for S3 horiz. fixed l=800mm M
KL3211	Kit for S3 vert. fixed not segreg. l=800 mm K
KM3110	Kit for S3 horiz. fixed segreg. mot K
KM3120	Kit for S3 horiz. plug-in segreg. mot. K
KM3121	Kit for S3 horiz. plug-in not segreg. mot. K
KS3100	Kit for S3 horiz. fixed RC mod. segreg. K
KS3101	Kit for S3 horiz. fixed RC mod. not segreg. K
KS3102	Kit for S3 horiz. fixed RC mod. not segreg. M
KS3110	Kit for S3 horiz. fixed segreg. K
KS3111	Kit for S3 horiz. fixed not segreg. K
KS3112	Kit for S3 horiz. fixed not segreg. M
KS3118	Kit for S3 3/4P horiz. fixed not segreg. M, K
KS3119	Kit for S3 horiz. fixed front term. not segreg. K
KS3120	Kit for S3 horiz. plug-in segreg. K
KS3121	Kit for S3 horiz. plug-in not segreg. K
KS3130	Kit for S3 horiz. withdrawable segreg. K
KS3131	Kit for S3 horiz. withdrawable not segreg. K
KS3211	Kit for S3 vert. fixed not segreg. K
KS3212	Kit for S3 vert. fixed not segreg. M
KS3221	Kit for S3 vert. plug-in not segreg. K
KS3231	Kit for S3 vert. withdr. not segreg. K
KS3410	Kit for S3 horiz. fixed segreg. 300x400mm (hwx) K
KS3411	Kit for S3 horiz. fixed 300x400mm (hwx) K
KS3416	Kit for S3 3/4P vert. fixed 400x400mm (hwx) K
KS3419	Kit for S3 horiz. fixed ant. 200x400mm (hwx) K
KS3420	Kit for S3 horiz. plug-in segreg. 300x400mm (hwx) K
KS3421	Kit for S3 horiz. plug-in 300x400mm (hwx) K
KS3426	Kit for S3 3/4P vert. plug-in 400x400mm (hwx)
KS3430	Kit for S3 horiz. withdr. segreg. 300x400mm (hwx) K
KS3431	Kit for S3 horiz. withdr. 300x400mm (hwx) K
KS3436	Kit for S3 3/4P vert. withdr. 400x400mm (hwx)
LK4000	Kit for floor S3 horiz. 3/4P 200x600mm (hwx) W
LK4002	Kit for floor S3 vert. in cable cont. 400x300mm (hwx) W
PM2211	Kit for S3 front term. fixed vert. not segreg. K
PM2212	Kit for S3 front term. fixed vert. not segreg. M
PM2213	Kit for S3 front term. fixed vert. not segreg. l=800mm K
PM2214	Kit for S3 front term. fixed vert. not segreg. l=800mm M

ArTu L-M-K

Kit which can be managed at time of offer

Kit for Isomax S4

Code	Description
KI4111	Kit for S4 fixed not segreg. interlocked K
KI4112	Kit for S4 fixed segreg. interlocked mot. K
KI4122	Kit for S4 plug-in segreg. interlocked mot. K
KI4130	Kit for S4 withdrawable segreg. interlocked K
KI4131	Kit for S4 withdrawable not segreg. interlocked K
KI4132	Kit for S4 withdrawable segreg. interlocked mot. K
KL4111	Kit for S4 horiz. fixed not segreg. l=800mm K
KL4112	Kit for S4 horiz. fixed l=800mm M
KL4211	Kit for S4 vert. fixed not segreg. l=800mm K
KM4110	Kit for S4 horiz. fixed segreg. mot. K
KM4120	Kit for S4 horiz. plug-in segreg. mot. K
KM4121	Kit for S4 horiz. plug-in not segreg. mot. K
KS4110	Kit for S4 horiz. fixed segreg. K
KS4111	Kit for S4 horiz. fixed not segreg. K
KS4112	Kit for S4 horiz. fixed not segreg. M
KS4119	Kit for S4 horiz. fixed not segreg. K
KS4120	Kit for S4 horiz. plug-in segreg. K
KS4121	Kit for S4 horiz. plug-in not segreg. K
KS4130	Kit for S4 horiz. withdrawable segreg. K
KS4131	Kit for S4 horiz. withdrawable not segreg. K
KS4211	Kit for S4 vert. fixed not segreg. K
KS4212	Kit for S4 vert. fixed not segreg. M
KS4221	Kit for S4 vert. plug-in not segreg. K
KS4231	Kit for S4 vert. withdrawable not segreg. K
KS4410	Kit for S4 3/4P horiz. fixed segreg. 300x400mm (hwx) K
KS4411	Kit for S4 3/4P vert. fixed 400x400mm (hwx) K
KS4420	Kit for S4 3/4P horiz. plug-in segreg. 300x400mm (hwx) K
KS4421	Kit for S4 3/4P vert. plug-in 400x400mm (hwx) K
KS4430	Kit for S4 3/4P horiz. withdr. segreg. 300x400mm (hwx) K
KS4431	Kit for S4 3/4P vert. withdr. 400x400mm (hwx) K
LK4001	Kit for floor S4 vert. 3/4P W 400x600mm (hwx) W
LK4000	Kit for floor S4 horiz. 3/4P 200x600mm (hwx) W
LK4002	Kit for floor S4 vert. in cable cont. 400x300mm (hwx) W
PM2211	Kit for S4 front term. fixed vert. not segreg. K
PM2212	Kit for S4 front term. fixed vert. not segreg. M
PM2213	Kit for S4 front term. fixed vert. not segreg. l=800mm K
PM2214	Kit for S4 front term. fixed vert. not segreg. l=800mm M

ArTu L-M-K

Kit which can be managed at time of offer

Kit for Isomax S5

Code	Description
KI5110	Kit for S5 fixed segreg. interlocked K
KI5111	Kit for S5 fixed not segreg. interlocked K
KI5112	Kit for S5 fixed segreg. interlocked mot. K
KI5130	Kit for S5 withdrawable segreg. interlocked K
KI5131	Kit for S5 withdrawable not segreg. interlocked K
KL5111	Kit for S5 horiz. fixed not segreg. l=800mm K
KL5112	Kit for S5 horiz. fixed l=800mm M
KL5211	Kit for S5 fixed vert. not segreg. l=800mm K
KM5110	Kit for S5 horiz. fixed segreg. mot. K
KM5120	Kit for S5 horiz. plug-in segreg. mot. K
KM5121	Kit for S5 horiz. plug-in not segreg. mot. K
KM5210	Kit for S5 vert. fixed segreg. mot. K
KM5220	Kit for S5 vert. plug-in segreg. mot. K
KM5221	Kit for S5 vert. plug-in not segreg. mot. K
KS5110	Kit for S5 horiz. fixed segreg. K
KS5111	Kit for S5 horiz. fixed not segreg. K
KS5112	Kit for S5 horiz. fixed not segreg. M
KS5120	Kit for S5 horiz. plug-in segreg. K
KS5121	Kit for S5 horiz. plug-in not segreg. K
KS5130	Kit for S5 horiz. withdrawable segreg. K
KS5131	Kit for S5 horiz. withdrawable not segreg. K
KS5210	Kit for S5 vert. fixed segreg. K
KS5211	Kit for S5 fixed vert. not segreg. K
KS5212	Kit for S5 vert. fixed not segreg. M
KS5220	Kit for S5 vert. plug-in segreg. K
KS5221	Kit for S5 vert. plug-in not segreg. K
KS5230	Kit for S5 withdr. vert. segreg. K
KS5231	Kit for S5 vert. withdr. not segreg. K
KS5410	Kit for S5 3/4P horiz. fixed segreg. 400x400mm (hwx) K
KS5411	Kit for S5 3/4P vert. fixed 500x400mm (hwx) K
KS5420	Kit for S5 3/4P horiz. plug-in segreg. 400x400mm (hwx) K
KS5421	Kit for S5 3/4P vert. plug-in 500x400mm (hwx) K
KS5430	Kit for S5 3/4P horiz. withdr. segreg. 400x400mm (hwx) K
KS5431	Kit for S5 3/4P vert. withdr. 500x400mm (hwx) K
LK5000	Kit for floor S5 horiz. 3/4P 300x600mm (hwx) W
LK5001	Kit for floor S5 vert. 3/4P W 500x600mm (hwx) W
LK5002	Kit for floor S5 vert. in cable cont. W 500x300mm (hwx) W
PM2211	Kit for S5 front term. fixed vert. not segreg. K
PM2212	Kit for S5 front term. fixed vert. not segreg. M
PM2213	Kit for S5 front term. fixed vert. not segreg. l=800mm K
PM2214	Kit for S5 front term. fixed vert. not segreg. l=800mm M

ArTu L-M-K

Kit which can be managed at time of offer

Kit for Isomax S6

Code	Description
KI6210	Kit for S6 4 P fixed (I) 24 DIN modules W=600mm H=800mm
KI6211	Kit for S6 3/4 P fixed (I) 24 DIN modules W=600mm H=800mm
KI6212	Kit for S6 4 P fixed (IM) 24 DIN modules W=600mm H=800mm
KI6213	Kit for S6 3/4 P fixed (IM) 24 DIN modules W=600mm H=800mm
KI6230	Kit for S6 4 P withdrawable (I) 24 DIN modules W=600mm H=800mm
KI6231	Kit for S6 3/4 P withdrawable (I) 24 DIN modules W=600mm H=800mm
KI6232	Kit for S6 4 P withdrawable (IM) 24 DIN modules W=600mm H=800mm
KI6233	Kit for S6 3/4 P withdrawable (IM) 24 DIN modules W=600mm H=800mm
KL6112	Kit for S6 (400A) 3/4 P fixed 36 DIN modules W=800mm H=500mm
KL6211	Kit for S6 3/4 P fixed 36 DIN modules W=800mm H=500mm
KL6212	Kit for S6 3/4 P fixed 36 DIN modules W=800mm H=500mm
KM6110	Kit for S6 3/4 P fixed (MO) 24 DIN modules W=600mm H=500mm
KM6111	Kit for S6 3/4 P fixed (MO) 24 DIN modules W=600mm H=500mm
KM6130	Kit for S6 3/4 P withdrawable (MO) 24 DIN modules W=600mm H=500mm
KM6131	Kit for S6 3/4 P withdrawable (MO) 24 DIN modules W=600mm H=500mm
KM6210	Kit for S6 3/4 poles fixed (MO) 24 DIN modules W=600mm H=600mm
KM6211	Kit for S6 3/4 P fixed (MO) 24 DIN modules W=600mm H=500mm
KM6230	Kit for S6 3/4 poles withdrawable (MO) 24 DIN modules W=600mm H=600mm
KM6231	Kit for S6 3/4 P withdrawable (MO) 24 DIN modules W=600mm H=500mm
KR6110	Kit for S6 3/4 P fixed (DRH) 24 DIN modules W=600mm H=500mm
KR6111	Kit for S6 3/4 P fixed (DRH) 24 DIN modules W=600mm H=500mm
KR6210	Kit for S6 3/4 poles fixed (DRH) 24 DIN modules W=600mm H=600mm
KR6211	Kit for S6 3/4 P fixed (DRH) 24 DIN modules W=600mm H=500mm
KS6110	Kit for S6 3/4 P fixed 24 DIN modules W=600mm H=500mm
KS6111	Kit for S6 3/4 P fixed 24 DIN modules W=600mm H=500mm
KS6112	Kit for S6 (400A) 3/4 P fixed 24 DIN modules W=600mm H=500mm
KS6130	Kit for S6 3/4 P withdrawable (DRH) 24 DIN modules W=600mm H=500mm
KS6131	Kit for S6 3/4 P withdrawable (DRH) 24 DIN modules W=600mm H=500mm
KS6210	Kit for S6 3/4 poles fixed 24 DIN modules W=600mm H=600mm
KS6211	Kit for S6 3/4 P fixed 24 DIN modules W=600mm H=500mm
KS6212	Kit for S6 3/4 P fixed 24 DIN modules W=600mm H=500mm
KS6230	Kit for S6 3/4 poles withdrawable (DRH) 24 DIN modules W=600mm H=600mm
KS6231	Kit for S6 3/4 P withdrawable (DRH) 24 DIN modules W=600mm H=500mm
KS7110	Kit for S7 3/4 P fixed 24 DIN modules W=600mm H=600mm
KS7111	Kit for S7 3/4 P fixed 24 DIN modules W=600mm H=600mm
KS7210	Kit for S7 3/4 poles fixed 24 DIN modules W=600mm H=800mm
KS7211	Kit for S7 3/4 P fixed 24 DIN modules W=600mm H=700mm
KS7230	Kit for S7 4 poles withdrawable (DRH) 24 DIN modules W=600mm H=800mm

ArTu L-M-K

Kit which can be managed at time of offer

Kit for Isomax S7

Code	Description
KS7231	Kit for S7 3/4 P withdrawable (MRD-CM) 24 DIN modules W=600mm H=700mm
LK6001	Kit for S6 3/4 P fixed 24 DIN modules W=600mm H=500mm
LK6101	Kit for S6 3/4 P fixed 36 DIN modules W=800mm H=500mm
KI7210	Kit for S7 4 P fixed (I)24 DIN modules W=600mm H=800mm
KI7211	Kit for S7 3/4 P fixed (I) 24 DIN modules W=600mm H=800mm
KI7212	Kit for S7 4 P fixed (IM)24 DIN modules W=600mm H=800mm
KI7213	Kit for S7 3/4 P fixed/withdrawable (IM) 24 DIN modules W=600mm H=800mm
KI7230	Kit for S7 4 P withdrawable (I)24 DIN modules W=600mm H=800mm
KI7231	Kit for S7 3/4 P withdrawable (I) 24 DIN modules W=600mm H=800mm
KI7232	Kit for S7 4 P withdrawable (IM)24 DIN modules W=600mm H=800mm
KL7211	Kit for S7 3/4 P fixed 36 DIN modules W=800mm H=700mm
KM7110	Kit for S7 3/4 P fixed (MO)24 DIN modules W=600mm H=600mm
KM7111	Kit for S7 3/4 P fixed (MO) 24 DIN modules W=600mm H=600mm
KM7210	Kit for S7 4 poles fixed (MO) 24 DIN modules W=600mm H=800mm
KM7211	Kit for S7 3/4 P fixed (MO) 24 DIN modules W=600mm H=700mm
KM7230	Kit for S7 4 poles withdrawable (MO) 24 DIN modules W=600mm H=800mm
KM7231	Kit for S7 3/4 P withdrawable (MO) 24 DIN modules W=600mm H=700mm
KR7110	Kit for S7 3/4 P fixed (DRH)24 DIN modules W=600mm H=600mm
KR7111	Kit for S7 3/4 P fixed (DRH) 24 DIN modules W=600mm H=600mm
KR7210	Kit for S7 4 poles fixed (DRH) 24 DIN modules W=600mm H=800mm
KR7211	Kit for S7 3/4 P fixed (DRH) 24 DIN modules W=600mm H=700mm
KS7110	Kit for S7 3/4 P fixed 24 DIN modules W=600mm H=600mm
KS7111	Kit for S7 3/4 P fixed 24 DIN modules W=600mm H=600mm
KS7210	Kit for S7 3/4 poles fixed 24 DIN modules W=600mm H=800mm
KS7211	KS7211 Kit for S7 3/4 P fixed 24 DIN modules W=600mm H=700mm
KS7230	Kit for S7 4 poles withdrawable (DRH) 24 DIN modules W=600mm H=800mm
KS7231	Kit for S7 3/4 P withdrawable (MRD-CM) 24 DIN modules W=600mm H=700mm

List of codes

Code	Structure	Weight (Kg)	Page	Code	Structure	Weight (Kg)	Page	Code	Structure	Weight (Kg)	Page
05 270	Gemini		9/7	1SL0277A00	Gemini		9/7	1SL0363A00	Gemini		9/6
05 272	Gemini		9/7	1SL0278A00	Gemini		9/7	1SL0370A00	Gemini		9/5
05 274	Gemini		9/7	1SL0279A00	Gemini		9/7	1SL0371A00	Gemini		9/5
05 276	Gemini		9/7	1SL0280A00	Gemini		9/7	1SL0372A00	Gemini		9/5
05 278	Gemini		9/7	1SL0283A00	Gemini		9/4	1SL0380A00	Gemini		9/11
05 280	Gemini		9/7	1SL0284A00	Gemini		9/4	1SL0381A00	Gemini		9/11
05 282	Gemini		9/7	1SL0285A00	Gemini		9/4	1SL0382A00	Gemini		9/11
12 849	Gemini		9/11	1SL0286A00	Gemini		9/4	1SL0383A00	Gemini		9/7
12 851	Gemini		9/11	1SL0287A00	Gemini		9/4	1SL0385A00	Gemini		9/9
12 863	Gemini		9/11	1SL0290A00	Gemini		9/4	1SL0386A00	Gemini		9/9
1SL0201A00	Gemini		9/2	1SL0291A00	Gemini		9/4	1SL0387A00	Gemini		9/9
1SL0202A00	Gemini		9/2	1SL0292A00	Gemini		9/4	1SL0388A00	Gemini		9/9
1SL0203A00	Gemini		9/2	1SL0293A00	Gemini		9/4	1SL0390A00	Gemini		9/9
1SL0204A00	Gemini		9/2	1SL0296A00	Gemini		9/5	1SL0397A00	Gemini		9/11
1SL0205A00	Gemini		9/2	1SL0297A00	Gemini		9/5	1SL0413A00	Gemini		9/10
1SL0206A00	Gemini		9/2	1SL0298A00	Gemini		9/5	1SL0414A00	Gemini		9/10
1SL0211A00	Gemini		9/2	1SL0299A00	Gemini		9/5	1SL0415A00	Gemini		9/10
1SL0212A00	Gemini		9/2	1SL0302A00	Gemini		9/5	1SL0416A00	Gemini		9/10
1SL0213A00	Gemini		9/2	1SL0303A00	Gemini		9/5	1SL0423A00	Gemini		9/10
1SL0214A00	Gemini		9/2	1SL0304A00	Gemini		9/5	1SL0424A00	Gemini		9/10
1SL0215A00	Gemini		9/2	1SL0307A00	Gemini		9/4	1SL0425A00	Gemini		9/10
1SL0216A00	Gemini		9/2	1SL0308A00	Gemini		9/4	1SL0426A00	Gemini		9/10
1SL0221A00	Gemini		9/3	1SL0309A00	Gemini		9/4	1SL0433A00	Gemini		9/10
1SL0222A00	Gemini		9/3	1SL0310A00	Gemini		9/4	1SL0434A00	Gemini		9/10
1SL0223A00	Gemini		9/3	1SL0313A00	Gemini		9/4	1SL0435A00	Gemini		9/10
1SL0224A00	Gemini		9/3	1SL0314A00	Gemini		9/4	1SL0436A00	Gemini		9/10
1SL0225A00	Gemini		9/3	1SL0315A00	Gemini		9/4	1SL0457A00	Gemini		9/11
1SL0226A00	Gemini		9/3	1SL0318A00	Gemini		9/6	1SL0458A00	Gemini		9/9
1SL0231A00	Gemini		9/3	1SL0319A00	Gemini		9/6	AA....			
1SL0232A00	Gemini		9/3	1SL0320A00	Gemini		9/6	AA1000	ArTuL	0,15	9/28
1SL0233A00	Gemini		9/3	1SL0321A00	Gemini		9/6	AA1001	ArTu L	0,15	9/28
1SL0234A00	Gemini		9/3	1SL0324A00	Gemini		9/6	AA1206	ArTu M	0,2	9/46
1SL0235A00	Gemini		9/3	1SL0325A00	Gemini		9/6	AA1560	ArTu L		9/31
1SL0236A00	Gemini		9/3	1SL0326A00	Gemini		9/6	AA1560	ArTu M	0,02	9/50
1SL0241A00	Gemini		9/3	1SL0327A00	Gemini		9/6	AA1560	ArTu K	0,02	9/82
1SL0242A00	Gemini		9/3	1SL0330A00	Gemini		9/6	AA1570	ArTu L	0,03	9/31
1SL0243A00	Gemini		9/3	1SL0331A00	Gemini		9/6	AA1570	ArTu M	0,03	9/50
1SL0244A00	Gemini		9/3	1SL0332A00	Gemini		9/6	AA1570	ArTu K	0,03	9/82
1SL0245A00	Gemini		9/3	1SL0333A00	Gemini		9/6	AA5600	ArTu L	0,2	9/29
1SL0246A00	Gemini		9/3	1SL0336A00	Gemini		9/5	AA5600	ArTu M	0,2	9/47
1SL0251A00	Gemini		9/3	1SL0337A00	Gemini		9/5	AA5600	ArTu K	0,2	9/79
1SL0252A00	Gemini		9/3	1SL0338A00	Gemini		9/5	AA6100	ArTu L	0,01	9/31
1SL0253A00	Gemini		9/3	1SL0339A00	Gemini		9/9	AA6100	ArTu M	0,01	9/50
1SL0254A00	Gemini		9/3	1SL0340A00	Gemini		9/9	AA6100	ArTu K	0,01	9/82
1SL0255A00	Gemini		9/3	1SL0341A00	Gemini		9/9	AA6120	ArTu L	0,01	9/31
1SL0256A00	Gemini		9/3	1SL0342A00	Gemini		9/9	AA6120	ArTu M	0,01	9/50
1SL0259A00	Gemini		9/7	1SL0343A00	Gemini		9/9	AA6120	ArTu K	0,01	9/82
1SL0260A00	Gemini		9/7	1SL0344A00	Gemini		9/9	AA6140	ArTu L	0,01	9/31
1SL0261A00	Gemini		9/7	1SL0345A00	Gemini		9/9	AA6140	ArTu M	0,01	9/50
1SL0262A00	Gemini		9/7	1SL0346A00	Gemini		9/9	AA6140	ArTu K	0,01	9/82
1SL0263A00	Gemini		9/7	1SL0350A00	Gemini		9/11	AA6160	ArTu L	0,02	9/31
1SL0264A00	Gemini		9/7	1SL0351A00	Gemini		9/11	AA6160	ArTu M	0,02	9/50
1SL0267A00	Gemini		9/7	1SL0352A00	Gemini		9/9	AA6160	ArTu K	0,02	9/82
1SL0268A00	Gemini		9/7	1SL0353A00	Gemini		9/6	AA6180	ArTu L	0,02	9/31
1SL0269A00	Gemini		9/7	1SL0354A00	Gemini		9/6	AA6180	ArTu M	0,02	9/50
1SL0270A00	Gemini		9/7	1SL0355A00	Gemini		9/6	AA6180	ArTu K	0,02	9/82
1SL0271A00	Gemini		9/7	1SL0356A00	Gemini		9/6	AA6200	ArTu L	0,02	9/31
1SL0272A00	Gemini		9/7	1SL0360A00	Gemini		9/6	AA6200	ArTu M	0,02	9/50
1SL0275A00	Gemini		9/7	1SL0361A00	Gemini		9/6	AA6200	ArTu K	0,02	9/82
1SL0276A00	Gemini		9/7	1SL0362A00	Gemini		9/6	AA8002	ArTu M	0,01	9/50

List of codes

Code	Structure	Weight (Kg)	Page	Code	Structure	Weight (Kg)	Page	Code	Structure	Weight (Kg)	Page
AA8004	ArTu L	0,01	9/31	AD1051	ArTu K	2,94	9/63	AD1086	ArTu L	3,51	9/19
AA8004	ArTu M	0,01	9/50	AD1053	ArTu M	10	9/48	AD1086	ArTu M	3,51	9/36
AA8004	ArTu K	0,01	9/82	AD1053	ArTu K	10	9/81	AD1086	ArTu K	3,51	9/57
AA8005	ArTu M	0,01	9/50	AD1054	ArTu M	0,9	9/47	AD1088	ArTu L	1,41	9/19
AA9600	ArTu M	0,5	9/46	AD1054	ArTu K	0,9	9/80	AD1088	ArTu M	1,41	9/36
AA9610	ArTu K	0,7	9/78	AD1055	ArTu M	1,67	9/47	AD1088	ArTu K	1,41	9/57
AD....											
AD1001	ArTu K	0,2	9/82	AD1055	ArTu K	1,67	9/80	AD1089	ArTu L	2,08	9/19
AD1004	ArTu M	0,55	9/48	AD1056	ArTu L	0,3	9/22	AD1089	ArTu M	2,08	9/36
AD1004	ArTu K	0,55	9/81	AD1056	ArTu M	0,3	9/40	AD1089	ArTu K	2,08	9/57
AD1005	ArTu L	0,42	9/28	AD1056	ArTu K	0,3	9/70	AD1090	ArTu L	0,51	9/31
AD1006	ArTu L	0,55	9/29	AD1057	ArTu M	28	9/50	AD1090	ArTu M	0,51	9/50
AD1006	ArTu M	0,55	9/48	AD1057	ArTu K	28	9/82	AD1090	ArTu K	0,51	9/82
AD1006	ArTu K	0,55	9/81	AD1058	ArTu L	0,01	9/31	AD1091	ArTu L	0,33	9/31
AD1007	ArTu L	0,25	9/29	AD1058	ArTu M	0,01	9/50	AD1091	ArTu M	0,33	9/50
AD1007	ArTu M	0,25	9/48	AD1058	ArTu K	0,01	9/82	AD1091	ArTu K	0,33	9/82
AD1007	ArTu K	0,25	9/81	AD1061	ArTu M	0,88	9/37	AD1092	ArTu K	1,62	9/82
AD1009	ArTu L	0,01	9/18	AD1061	ArTu M	0,88	9/43	AD1096	ArTu L	0,15	9/18
AD1009	ArTu M	0,01	9/37	AD1061	ArTu M	0,88	9/44	AD1097	ArTu L	0,56	9/25
AD1009	ArTu K	0,01	9/58	AD1061	ArTu K	0,88	9/58	AD1098	ArTu L	0,96	9/18
AD1012	ArTu M	0,2	9/46	AD1061	ArTu K	0,88	9/75	AD1099	ArTu L	0,61	9/28
AD1014	ArTu K	0,50	9/78	AD1061	ArTu K	0,88	9/76	AD1101	ArTu L	0,05	9/19
AD1015	ArTu K	0,2	9/79	AD1063	ArTu K	4,16	9/69	AD1101	ArTu M	0,05	9/36
AD1022	ArTu L	0,32	9/31	AD1064	ArTu L	0,26	9/22	AD1101	ArTu K	0,05	9/57
AD1022	ArTu M	0,32	9/50	AD1064	ArTu M	0,26	9/40	AD1102	ArTu L	0,02	9/19
AD1022	ArTu K	0,32	9/82	AD1064	ArTu K	0,26	9/70	AD1102	ArTu M	0,02	9/36
AD1024	ArTu K	5,5	9/68	AD1064	ArTu K	0,26	9/70	AD1102	ArTu K	0,02	9/57
AD1025	ArTu K	6	9/68	AD1065	ArTu L	0,2	9/22	AD1103	ArTu L	0,02	9/19
AD1027	ArTu M	0,25	9/48	AD1065	ArTu M	0,2	9/40	AD1103	ArTu M	0,02	9/36
AD1027	ArTu K	0,25	9/81	AD1065	ArTu K	0,2	9/70	AD1103	ArTu K	0,02	9/57
AD1028	ArTu M	0,5	9/48	AD1066	ArTu K	0,2	9/70	AD1104	ArTu L	0,02	9/19
AD1028	ArTu K	0,5	9/81	AD1068	ArTu L	1,07	9/22	AD1104	ArTu M	0,02	9/36
AD1029	ArTu M	0,55	9/48	AD1068	ArTu M	1,07	9/40	AD1104	ArTu K	0,02	9/57
AD1029	ArTu K	0,55	9/81	AD1068	ArTu K	1,07	9/69	AD1390	ArTu K	0,12	9/57
AD1030	ArTu L	1,11	9/29	AD1069	ArTu K	2,4	9/69	AD1600	ArTu L	0,24	9/19
AD1030	ArTu M	1,11	9/48	AD1070	ArTu L	0,03	9/31	AD1600	ArTu M	0,24	9/36
AD1030	ArTu K	1,11	9/81	AD1070	ArTu M	0,03	9/50	AD1600	ArTu K	0,24	9/57
AD1031	ArTu L	1,25	9/29	AD1070	ArTu K	0,03	9/82	AD1800	ArTu L	0,36	9/19
AD1031	ArTu M	1,25	9/48	AD1071	ArTu K	0,25	9/70	AD1800	ArTu M	0,36	9/36
AD1031	ArTu K	1,25	9/81	AD1072	ArTu K	0,32	9/70	AD1800	ArTu K	0,36	9/57
AD1033	ArTu L	0,22	9/31	AD1073	ArTu K	6,55	9/69	AD1808	ArTu K	0,18	9/78
AD1033	ArTu M	0,22	9/50	AD1075	ArTu L	0,55	9/29	AD3301	ArTu L-M-K	0,15	9/18-9/37-9/58
AD1033	ArTu K	0,22	9/82	AD1075	ArTu M	0,55	9/48	AD3302	ArTu L-M-K	0,15	9/18-9/37-9/58
AD1034	ArTu M	2,3	9/48	AD1075	ArTu K	0,55	9/81	AD3303	ArTu L-M-K	0,15	9/18-9/37-9/58
AD1034	ArTu K	2,3	9/81	AD1076	ArTu L	0,25	9/29	AD3304	ArTu L-M-K	0,15	9/18-9/37-9/58
AD1035	ArTu M	0,12	9/48	AD1076	ArTu M	0,25	9/48	AD3305	ArTu L-M-K	0,15	9/21-39-61-62-65-66
AD1036	ArTu L	0,2	9/31	AD1076	ArTu K	0,25	9/81	AD3306	ArTu L-M-K	0,15	9/21-39-61-62-65-66
AD1036	ArTu M	0,2	9/50	AD1077	ArTu L	1,05	9/22	AD3307	ArTu L-M-K	0,15	9/21-39-61-62-65-66
AD1036	ArTu K	0,2	9/82	AD1077	ArTu M	1,05	9/40	AD3308	ArTu L-M-K	0,15	9/21-39-61-62-65-66
AD1037	ArTu M	0,34	9/37	AD1077	ArTu K	1,05	9/69	AL....			
AD1037	ArTu K	0,34	9/58	AD1078	ArTu K	6,38	9/69	AL1000	ArTu L	0,18	9/28
AD1038	ArTu L	0,14	9/29	AD1080	ArTu L	0,25	9/29	AL1001	ArTu L	1,35	9/28
AD1041	ArTu M	0,34	9/47	AD1080	ArTu M	0,25	9/48	AL2000	ArTu L	0,12	9/28
AD1041	ArTu K	0,34	9/80	AD1080	ArTu K	0,25	9/81	AP....			
AD1042	ArTu K	0,2	9/68	AD1081	ArTu L	0,25	9/29	AP6000	ArTu L	0,01	9/18
AD1044	ArTu M	0,99	9/47	AD1081	ArTu M	0,25	9/48	AP6001	ArTu M	0,01	9/37
AD1047	ArTu K	0,2	9/82	AD1081	ArTu K	0,25	9/81	AP6001	ArTu K	0,01	9/58
AD1048	ArTu K	0,2	9/82	AD1081	ArTu L	0,25	9/29	AZ....			
AD1049	ArTu K	2,45	9/63	AD1083	ArTu L	0,25	9/29	AZ4000	ArTu M	3,5	9/50
AD1050	ArTu K	2,45	9/63	AD1083	ArTu M	0,25	9/48	AZ4000	ArTu K	3,5	9/78

List of codes

Code	Structure	Weight (Kg)	Page	Code	Structure	Weight (Kg)	Page	Code	Structure	Weight (Kg)	Page
AZ4000	ArTu K	3,5	9/82	BR1250	ArTu K	14,5	9/73	ED2266	ArTu L	0,23	9/26
BA....				BR1600	ArTu K	29	9/73	ED2266	ArTu M	0,23	9/44
BA0400	ArTu L	3,3	9/22	BR2000	ArTu K	34,8	9/73	ED2266	ArTu K	0,23	9/76
BA0400	ArTu M	3,3	9/40	BR4005	ArTu K	4,4	9/73	ED2274	ArTu L	0,23	9/26
BA0400	ArTu K	3,3	9/69	BR6305	ArTu K	6,5	9/73	ED2274	ArTu M	0,23	9/44
BA0800	ArTu L	4,5	9/22	BR8005	ArTu K	8,6	9/73	ED2274	ArTu K	0,23	9/76
BA0800	ArTu M	4,5	9/40	BS....				ED2282	ArTu L	0,18	9/26
BA0800	ArTu K	4,5	9/69	BS3250	ArTu K	1,5	9/73	ED2282	ArTu M	0,18	9/44
BA1250	ArTu K	9,16	9/69	BS5050	ArTu K	0,8	9/73	ED2282	ArTu K	0,18	9/76
BA1600	ArTu K	10,72	9/69	BS6350	ArTu K	0,95	9/73	ED2290	ArTu L	0,25	9/26
BA2000	ArTu K	15,7	9/69	CA....				ED2290	ArTu M	0,25	9/44
BF....				CA1401	ArTu M	1,37	9/50	ED2290	ArTu K	0,25	9/76
BF1602	ArTu L	2,7	9/22	CA1600	ArTu M	1,57	9/50	ED2308	ArTu L	0,27	9/26
BF1602	ArTu L	2,7	9/24	CA1600	ArTu K	1,57	9/82	ED2308	ArTu M	0,27	9/44
BF1602	ArTu M	2,7	9/40	CA1800	ArTu M	1,77	9/50	ED2308	ArTu K	0,27	9/76
BF1602	ArTu M	2,7	9/42	CA1800	ArTu K	1,77	9/82	ED2316	ArTu L	0,29	9/26
BF1602	ArTu K	2,7	9/73	CA2000	ArTu M	1,97	9/50	ED2316	ArTu M	0,29	9/44
BF2502	ArTu L	4,2	9/22	CA2000	ArTu K	1,97	9/82	ED2316	ArTu K	0,29	9/76
BF2502	ArTu L	4,2	9/24	ED....				ED2324	ArTu L	0,23	9/26
BF2502	ArTu M	4,2	9/40	ED0001	ArTu L	0,22	9/26	ED2324	ArTu M	0,23	9/44
BF2502	ArTu M	4,2	9/42	ED0001	ArTu M	0,22	9/44	ED2324	ArTu K	0,23	9/76
BF2502	ArTu K	4,2	9/73	ED0002	ArTu L	0,28	9/26	ED2332	ArTu L	0,25	9/26
BF4002	ArTu L	3	9/22	ED0002	ArTu M	0,28	9/44	ED2332	ArTu M	0,25	9/44
BF4002	ArTu L	3	9/24	ED0002	ArTu L	0,28	9/44	ED2332	ArTu K	0,25	9/76
BF4002	ArTu M	3	9/40	ED0003	ArTu L	0,29	9/26	ED2340	ArTu L	0,22	9/26
BF4002	ArTu M	3	9/42	ED0003	ArTu M	0,29	9/44	ED2340	ArTu M	0,22	9/44
BF4002	ArTu K	3	9/73	ED0003	ArTu L	0,29	9/26	ED2340	ArTu K	0,22	9/76
BF4012	ArTu L	6,5	9/22	ED0004	ArTu L	0,29	9/26	ED2357	ArTu L	0,20	9/26
BF4012	ArTu L	6,5	9/24	ED0004	ArTu M	0,29	9/44	ED2357	ArTu M	0,20	9/44
BF4012	ArTu M	6,5	9/40	ED0025	Gemini	1,91	9/8	ED2357	ArTu K	0,20	9/76
BF4012	ArTu M	6,5	9/42	ED0025	ArTu L	1,91	9/27	ED2365	ArTu L	0,27	9/26
BF4012	ArTu K	6,5	9/73	ED0025	ArTu M	1,91	9/45	ED2365	ArTu M	0,27	9/44
BF6302	ArTu K	12,5	9/73	ED0025	ArTu K	1,91	9/77	ED2365	ArTu K	0,27	9/76
BF8002	ArTu K	19,1	9/73	ED0026	Gemini	1,33	9/8	ED2373	ArTu L	0,09	9/26
BP....				ED0026	ArTu L	1,33	9/27	ED2373	ArTu L	0,09	9/26
BP0630	ArTu L	0,4	9/24	ED0026	ArTu M	1,33	9/45	ED2373	ArTu L	0,09	9/26
BP0630	ArTu M	0,4	9/42	ED0026	ArTu K	1,33	9/77	ED2373	ArTu M	0,09	9/44
BP0630	ArTu K	0,4	9/73	ED2183	ArTu L	3,1	9/25	ED2373	ArTu M	0,09	9/44
BP0632	ArTu L	0,55	9/24	ED2183	ArTu M	3,1	9/43	ED2373	ArTu M	0,09	9/44
BP0632	ArTu M	0,55	9/42	ED2183	ArTu K	3,1	9/75	ED2373	ArTu K	0,09	9/76
BP0632	ArTu K	0,55	9/73	ED2191	ArTu L	4,1	9/25	ED2373	ArTu K	0,09	9/76
BP0634	ArTu L	0,45	9/24	ED2191	ArTu M	4,1	9/43	ED2373	ArTu K	0,09	9/76
BP0634	ArTu M	0,45	9/42	ED2191	ArTu K	4,1	9/75	ED2381	ArTu L	0,26	9/26
BP0634	ArTu K	0,45	9/73	ED2209	ArTu L	1,45	9/25	ED2381	ArTu M	0,26	9/44
BP1250	ArTu K	2,8	9/73	ED2209	ArTu M	1,45	9/43	ED2381	ArTu K	0,26	9/76
BP1600	ArTu K	2,6	9/73	ED2209	ArTu K	1,45	9/75	ED2399	ArTu L	0,23	9/26
BP2500	ArTu K	4,3	9/73	ED2217	ArTu L	0,15	9/26	ED2399	ArTu M	0,23	9/44
BP3200	ArTu K	4,4	9/73	ED2217	ArTu M	0,15	9/44	ED2399	ArTu K	0,23	9/76
BR....				ED2217	ArTu K	0,15	9/76	ED2407	ArTu L	0,26	9/26
BR0250	ArTu L	1,3	9/24	ED2225	ArTu L	0,16	9/26	ED2407	ArTu M	0,26	9/44
BR0250	ArTu M	1,3	9/42	ED2225	ArTu M	0,16	9/44	ED2407	ArTu K	0,26	9/76
BR0250	ArTu K	1,3	9/73	ED2225	ArTu K	0,16	9/76	ED2531	ArTu L	0,08	9/25
BR0400	ArTu L	2,8	9/24	ED2233	ArTu L	0,18	9/26	ED2531	ArTu M	0,08	9/43
BR0400	ArTu M	2,8	9/42	ED2233	ArTu M	0,18	9/44	ED2531	ArTu K	0,08	9/75
BR0400	ArTu K	2,8	9/73	ED2233	ArTu K	0,18	9/76	ED2549	ArTu L	0,08	9/25
BR0630	ArTu L	6,2	9/24	ED2241	ArTu L	0,13	9/26	ED2549	ArTu M	0,08	9/43
BR0630	ArTu M	6,2	9/42	ED2241	ArTu M	0,13	9/44	ED2549	ArTu K	0,08	9/75
BR0630	ArTu K	6,2	9/73	ED2241	ArTu K	0,13	9/76	ED2550	ArTu L	0,073	9/25
				ED2258	ArTu L	0,2	9/26	ED2550	ArTu M	0,073	9/43
				ED2258	ArTu M	0,2	9/44	ED2550	ArTu K	0,073	9/75
				ED2258	ArTu K	0,2	9/76				

List of codes

Code	Structure	Weight (Kg)	Page	Code	Structure	Weight (Kg)	Page	Code	Structure	Weight (Kg)	Page
ED2551	ArTu L	0,125	9/25	ED2753	ArTu L	0,09	9/25	ED3017	ArTu K	0,47	9/77
ED2551	ArTu M	0,125	9/43	ED2753	ArTu M	0,09	9/43	ED3025	Gemini	0,67	9/8
ED2551	ArTu K	0,125	9/75	ED2753	ArTu K	0,09	9/75	ED3025	ArTu L	0,67	9/27
ED2552	ArTu L	0,125	9/25	ED2845	ArTu L	0,05	9/26	ED3025	ArTu M	0,67	9/45
ED2552	ArTu M	0,125	9/43	ED2845	ArTu M	0,05	9/44	ED3025	ArTu K	0,67	9/77
ED2552	ArTu K	0,125	9/75	ED2845	ArTu K	0,05	9/76	ED3033	Gemini	0,09	9/8
ED2553	ArTu L	0,125	9/25	ED2852	ArTu L	0,05	9/26	ED3033	ArTu L	0,09	9/27
ED2553	ArTu M	0,125	9/43	ED2852	ArTu M	0,05	9/44	ED3033	ArTu M	0,09	9/45
ED2553	ArTu K	0,125	9/75	ED2852	ArTu K	0,05	9/76	ED3033	ArTu K	0,09	9/77
ED2554	ArTu L	0,125	9/25	ED2894	ArTu L	0,08	9/25	ED3041	Gemini	0,07	9/8
ED2554	ArTu M	0,125	9/43	ED2894	ArTu M	0,08	9/43	ED3041	ArTu L	0,07	9/27
ED2554	ArTu K	0,125	9/75	ED2894	ArTu K	0,08	9/75	ED3041	ArTu M	0,07	9/45
ED2556	ArTu L	0,078	9/25	ED2902	ArTu L	0,06	9/25	ED3041	ArTu K	0,07	9/77
ED2556	ArTu M	0,078	9/43	ED2902	ArTu M	0,06	9/43	ED3058	Gemini	0,06	9/8
ED2556	ArTu K	0,078	9/75	ED2902	ArTu K	0,06	9/75	ED3058	ArTu L	0,06	9/27
ED2557	ArTu L	0,1	9/25	ED2910	ArTu L	0,07	9/25	ED3058	ArTu M	0,06	9/45
ED2557	ArTu M	0,1	9/43	ED2910	ArTu M	0,07	9/43	ED3058	ArTu K	0,06	9/77
ED2557	ArTu K	0,1	9/75	ED2910	ArTu K	0,07	9/75	ED3066	Gemini	0,08	9/8
ED2558	ArTu L	0,1	9/25	ED2928	ArTu L	0,08	9/25	ED3066	ArTu L	0,08	9/27
ED2558	ArTu M	0,1	9/43	ED2928	ArTu M	0,08	9/43	ED3066	ArTu M	0,08	9/45
ED2558	ArTu K	0,1	9/75	ED2928	ArTu K	0,08	9/75	ED3066	ArTu K	0,08	9/77
ED2559	ArTu L	0,1	9/25	ED2936	ArTu L	0,03	9/26	ED3082	Gemini	0,25	9/8
ED2559	ArTu M	0,1	9/43	ED2936	ArTu M	0,03	9/44	ED3082	ArTu L	0,25	9/27
ED2559	ArTu K	0,1	9/75	ED2936	ArTu K	0,03	9/76	ED3082	ArTu M	0,25	9/45
ED2560	ArTu L	0,1	9/25	ED2944	Gemini	0,36	9/8	ED3082	ArTu K	0,25	9/77
ED2560	ArTu M	0,1	9/43	ED2944	ArTu L	0,36	9/27	ED3090	Gemini	0,56	9/8
ED2560	ArTu K	0,1	9/75	ED2944	ArTu M	0,36	9/45	ED3090	ArTu L	0,56	9/27
ED2564	ArTu L	0,08	9/25	ED2944	ArTu K	0,36	9/77	ED3090	ArTu M	0,56	9/45
ED2564	ArTu M	0,08	9/43	ED2951	Gemini	0,56	9/8	ED3090	ArTu K	0,56	9/77
ED2564	ArTu K	0,08	9/75	ED2951	ArTu L	0,56	9/27	ED3101	Gemini	0,3	9/8
ED2572	ArTu L	0,08	9/25	ED2951	ArTu M	0,56	9/45	ED3101	ArTu L	0,3	9/27
ED2572	ArTu M	0,08	9/43	ED2951	ArTu K	0,56	9/77	ED3101	ArTu M	0,3	9/45
ED2572	ArTu K	0,08	9/75	ED2961	ArTu L	0,4	9/27	ED3101	ArTu K	0,3	9/77
ED2590	ArTu L	0,08	9/25	ED2961	ArTu M	0,4	9/45	ED3102	Gemini	0,3	9/8
ED2590	ArTu M	0,08	9/43	ED2961	ArTu K	0,4	9/77	ED3102	ArTu L	0,3	9/27
ED2590	ArTu K	0,08	9/75	ED2962	ArTu L	0,1	9/27	ED3102	ArTu M	0,3	9/45
ED2598	ArTu L	0,09	9/25	ED2962	ArTu M	0,1	9/45	ED3102	ArTu K	0,3	9/77
ED2598	ArTu M	0,09	9/43	ED2962	ArTu K	0,1	9/77	ED3103	Gemini	0,3	9/8
ED2598	ArTu K	0,09	9/75	ED2969	Gemini	0,75	9/8	ED3103	ArTu L	0,3	9/27
ED2606	ArTu L	0,09	9/25	ED2969	ArTu L	0,75	9/27	ED3103	ArTu M	0,3	9/45
ED2606	ArTu M	0,09	9/43	ED2969	ArTu M	0,75	9/45	ED3103	ArTu K	0,3	9/77
ED2606	ArTu K	0,09	9/75	ED2969	ArTu K	0,75	9/77	ED3104	Gemini	0,3	9/8
ED2654	ArTu L	0,06	9/25	ED2977	Gemini	1,09	9/8	ED3104	ArTu L	0,3	9/27
ED2654	ArTu M	0,06	9/43	ED2977	ArTu L	1,09	9/27	ED3104	ArTu M	0,3	9/45
ED2654	ArTu K	0,06	9/75	ED2977	ArTu M	1,09	9/45	ED3104	ArTu K	0,3	9/77
ED2662	ArTu L	0,06	9/25	ED2977	ArTu K	1,09	9/77	ED3108	Gemini	0,05	9/8
ED2662	ArTu M	0,06	9/43	ED2985	ArTu L	0,17	9/27	ED3108	ArTu L	0,05	9/27
ED2662	ArTu K	0,06	9/75	ED2985	ArTu M	0,17	9/45	ED3108	ArTu M	0,05	9/45
ED2670	ArTu L	0,08	9/25	ED2985	ArTu K	0,17	9/77	ED3108	ArTu K	0,05	9/77
ED2670	ArTu M	0,08	9/43	ED2993	Gemini	0,26	9/8	ED3116	Gemini	0,05	9/8
ED2670	ArTu K	0,08	9/75	ED2993	ArTu L	0,26	9/27	ED3116	ArTu L	0,05	9/27
ED2720	ArTu L	0,09	9/25	ED2993	ArTu M	0,26	9/45	ED3116	ArTu M	0,05	9/45
ED2720	ArTu M	0,09	9/43	ED2993	ArTu K	0,26	9/77	ED3116	ArTu K	0,05	9/77
ED2720	ArTu K	0,09	9/75	ED3009	Gemini	0,39	9/8	ED3124	Gemini	0,08	9/8
ED2738	ArTu L	0,09	9/25	ED3009	ArTu L	0,39	9/27	ED3124	ArTu L	0,08	9/27
ED2738	ArTu M	0,09	9/43	ED3009	ArTu M	0,39	9/45	ED3124	ArTu M	0,08	9/45
ED2738	ArTu K	0,09	9/75	ED3009	ArTu K	0,39	9/77	ED3124	ArTu K	0,08	9/77
ED2746	ArTu L	0,1	9/25	ED3017	Gemini	0,47	9/8	ED3132	Gemini	0,33	9/8
ED2746	ArTu M	0,1	9/43	ED3017	ArTu L	0,47	9/27	ED3132	ArTu L	0,33	9/27
ED2746	ArTu K	0,1	9/75	ED3017	ArTu M	0,47	9/45	ED3132	ArTu M	0,33	9/45

List of codes

Code	Structure	Weight (Kg)	Page	Code	Structure	Weight (Kg)	Page	Code	Structure	Weight (Kg)	Page
FH3965	ArTu K	6,50	9/67	GD7005	ArTu K	0,9	9/64	KB....			
FH3966	ArTu K	6,22	9/67	GD8002	ArTu M	1	9/37	KB1001	ArTu L	0,5	9/23
FH4220	ArTu K	0,7	9/67	GD8002	ArTu M	1	9/45	KB1002	ArTu L	0,95	9/23
FH4430	ArTu K	0,9	9/67	GD8002	ArTu K	1	9/58	KB1006	ArTu L	0,75	9/23
FH4540	ArTu K	1,1	9/67	GD8002	ArTu K	1	9/77	KB1010	ArTu L	0,6	9/23
FH4650	ArTu K	1,3	9/67	GD8010	ArTu M	1,9	9/37	KB1014	ArTu L	0,76	9/23
FH4760	ArTu K	1,5	9/67	GD8010	ArTu K	1,9	9/58	KB1018	ArTu L	0,64	9/23
FR....				GD9005	ArTu K	1,15	9/64	KB1019	ArTu L	3,59	9/23
FR2600	ArTu K	5	9/63	H7....				KB1020	ArTu L	4,59	9/23
FR2601	ArTu M	5	9/38	H70001	ArTu M	3,9	9/32	KB1021	ArTu L	5,25	9/23
FR2601	ArTu K	5	9/60	H70002	ArTu M	5,2	9/32	KB1022	ArTu L	5,59	9/23
FR2800	ArTu K	6	9/63	H70003	ArTu M	6,5	9/32	KB1024	ArTu L	6,59	9/23
FR2801	ArTu M	6	9/38	H70004	ArTu M	7,8	9/32	KE....			
FR2801	ArTu K	6	9/60	IP....				KE2215	ArTu K	13	9/66
FR4600	ArTu K	10,5	9/63	IP0600	ArTu L	0,43	9/17	KE2235	ArTu K	18	9/66
FR4601	ArTu M	10,5	9/38	IP0601	ArTu L	0,89	9/17	KE3205	ArTu K	13	9/66
FR4601	ArTu K	10,5	9/60	IP0602	ArTu L	0,44	9/17	KE3215	ArTu K	13	9/62
FR4800	ArTu K	11,5	9/63	IP0603	ArTu L	0,29	9/17	KE3235	ArTu K	13	9/62
FR4801	ArTu M	11,5	9/38	IP0604	ArTu L	1,25	9/17	KE3236	ArTu K	18	9/66
FR4801	ArTu K	11,5	9/60	IP0800	ArTu L	0,57	9/17	KE4214	ArTu K	13	9/66
FR6600	ArTu K	16	9/63	IP0800	ArTu L	0,57	9/17	KE4215	ArTu K	13	9/62
FR6800	ArTu K	17,5	9/63	IP0801	ArTu L	0,39	9/17	KE4234	ArTu K	13	9/66
FV....				IP1000	ArTu L	0,71	9/17	KE4235	ArTu K	13	9/62
FV3456	ArTu K	6,85	9/67	IP1001	ArTu L	0,49	9/17	KE5214	ArTu K	13,2	9/66
FV3458	ArTu K	7,94	9/67	IP1200	ArTu L	0,85	9/17	KE5215	ArTu K	13,2	9/62
FV3556	ArTu K	10	9/67	IP1201	ArTu L	0,58	9/17	KE5234	ArTu K	13,2	9/66
FV3558	ArTu K	12	9/67	IP1400	ArTu L	0,99	9/17	KE5235	ArTu K	13,2	9/62
FV3668	ArTu K	13	9/67	IP1401	ArTu L	0,68	9/17	KI....			
FV3788	ArTu K	15	9/67	IP1600	ArTu L	1,13	9/17	KI4114	ArTu K	12,65	9/61
FV4456	ArTu K	2,34	9/67	IP1601	ArTu L	0,78	9/17	KI4115	ArTu K	12,65	9/61
FV4458	ArTu K	3,28	9/67	IP1800	ArTu L	1,28	9/17	KI4116	ArTu K	22,45	9/65
FV4558	ArTu K	4,5	9/67	IP1801	ArTu L	0,88	9/17	KI4117	ArTu K	25,68	9/65
FV4668	ArTu K	5,5	9/67	IP2000	ArTu L	1,37	9/17	KI4118	ArTu K	25,68	9/65
FV4788	ArTu K	6,5	9/67	IP2001	ArTu L	0,96	9/17	KI4119	ArTu K	22,45	9/65
GC....				IP3030	ArTu K	0,7	9/54	KI5114	ArTu K	12,65	9/61
GC6002	ArTu M	1	9/37	IP3031	ArTu M	0,7	9/35	KI5115	ArTu K	12,65	9/61
GC6002	ArTu K	1	9/58	IP3040	ArTu K	0,5	9/54	KI5116	ArTu K	22,45	9/65
GC8002	ArTu M	1	9/37	IP3060	ArTu K	0,62	9/54	KI5117	ArTu K	25,68	9/65
GC8002	ArTu K	1	9/58	IP3061	ArTu M	0,7	9/35	KI5118	ArTu K	25,68	9/65
GD....				IP3080	ArTu K	0,7	9/54	KI5119	ArTu K	22,45	9/65
GD1520	ArTu L	0,8	9/18	IP3081	ArTu M	0,7	9/35	KL....			
GD1520	ArTu L	0,8	9/27	IP3140	ArTu M	0,7	9/35	KL1102	ArTu K	7,52	9/61
GD1530	ArTu L	1,79	9/18	IP3142	ArTu M	0,7	9/35	KL2103	ArTu M	5,1	9/39
GD1530	ArTu L	1,79	9/27	IP3160	ArTu M	0,7	9/35	KL2103	ArTu K	5,1	9/60
GD4002	ArTu K	0,8	9/58	IP3161	ArTu K	0,6	9/54	KL2104	ArTu K	7,2	9/61
GD4002	ArTu K	0,8	9/77	IP3162	ArTu M	0,7	9/35	KL3103	ArTu M	7,1	9/39
GD4005	ArTu K	0,8	9/64	IP3163	ArTu K	0,6	9/54	KL3103	ArTu K	7,1	9/60
GD6002	ArTu M	1	9/37	IP3180	ArTu K	0,7	9/54	KL3104	ArTu K	7,2	9/61
GD6002	ArTu M	1	9/45	IP3181	ArTu M	0,7	9/35	KL3113	ArTu M	4,95	9/39
GD6002	ArTu K	1	9/58	IP3182	ArTu K	0,7	9/54	KL3113	ArTu K	4,95	9/60
GD6002	ArTu K	1	9/77	IP3183	ArTu M	0,7	9/35	KL3114	ArTu K	7,76	9/61
GD6008	ArTu M	2,4	9/37	IP3201	ArTu M	0,7	9/35	KL3212	ArTu K	10,04	9/62
GD6008	ArTu K	2,4	9/58	IP3202	ArTu K	0,7	9/54	KL3613	ArTu K	4,95	9/62
GD6009	ArTu M	2,4	9/37	IP3203	ArTu M	0,7	9/35	KL4115	ArTu M	6,55	9/39
GD6009	ArTu K	2,4	9/58	IP4140	ArTu K	0,9	9/54	KL4115	ArTu K	6,55	9/60
GD6010	ArTu M	1,6	9/37	IP4141	ArTu K	1,28	9/54	KL4116	ArTu M	3,93	9/39
GD6010	ArTu K	1,6	9/58	IP4160	ArTu K	1,35	9/54	KL4116	ArTu K	3,93	9/60
GD6011	ArTu K	1,68	9/58	IP4161	ArTu K	2,44	9/54	KL4118	ArTu K	10,44	9/62
				IP4180	ArTu K	1,8	9/54	KL5102	ArTu M	15,42	9/39
				IP4181	ArTu K	3,22	9/54				

List of codes

Code	Structure	Weight (Kg)	Page	Code	Structure	Weight (Kg)	Page	Code	Structure	Weight (Kg)	Page
KL5102	ArTu K	15,42	9/60	KT1411	ArTu K	3,6	9/61	KT4126	ArTu K	8,44	9/62
KL5103	ArTu K	15,42	9/62	KT2101	ArTu K	5,4	9/61	KT4127	ArTu K	6,33	9/61
KL5114	ArTu M	9,22	9/39	KT2102	ArTu M	4	9/39	KT4128	ArTu K	8,44	9/66
KL5114	ArTu K	9,22	9/60	KT2102	ArTu K	4	9/60	KT4129	ArTu K	9,5	9/66
KL5116	ArTu M	5,90	9/39	KT2110	ArTu K	3,9	9/65	KT4130	ArTu K	4,74	9/65
KL5116	ArTu K	5,90	9/60	KT2111	ArTu K	3,89	9/61	KT4211	ArTu K	8,7	9/62
KL5117	ArTu K	13,25	9/62	KT2112	ArTu K	3,2	9/61	KT4212	ArTu M	9,25	9/39
KL5212	ArTu M	12,25	9/39	KT2117	ArTu M	3,89	9/39	KT4212	ArTu K	9,25	9/60
KL5212	ArTu K	12,25	9/60	KT2117	ArTu K	3,89	9/60	KT4221	ArTu K	8,44	9/62
KL5213	ArTu K	12,25	9/62	KT2120	ArTu K	3,9	9/65	KT4222	ArTu K	11,2	9/66
KL5214	ArTu K	11,65	9/62	KT2121	ArTu K	3,89	9/61	KT4231	ArTu K	8,44	9/62
KL6113	ArTu M	12,71	9/39	KT2210	ArTu K	3,89	9/65	KT4310	ArTu K	9,84	9/65
KL6113	ArTu K	12,71	9/60	KT2401	ArTu K	3,6	9/61	KT4320	ArTu K	14,77	9/65
KL6124	ArTu K	12,71	9/62	KT2410	ArTu K	2,8	9/65	KT4411	ArTu K	2,95	9/61
KL6213	ArTu M	12,71	9/39	KT2411	ArTu K	3,6	9/61	KT4412	ArTu K	4,66	9/62
KL6213	ArTu K	12,71	9/60	KT2420	ArTu K	2,7	9/65	KT5101	ArTu K	4,74	9/61
KL6214	ArTu K	12,71	9/62	KT2421	ArTu K	3,74	9/61	KT5102	ArTu M	11,42	9/39
KL7112	ArTu K	9,38	9/61	KT3101	ArTu K	5,4	9/61	KT5102	ArTu K	11,42	9/60
KL7212	ArTu K	12,31	9/62	KT3102	ArTu M	5,6	9/39	KT5103	ArTu K	10,55	9/62
KL7213	ArTu K	10,58	9/62	KT3102	ArTu K	5,6	9/60	KT5110	ArTu M	4,425	9/39
KO....				KT3110	ArTu K	5,6	9/65	KT5110	ArTu K	4,43	9/60
KO1201	ArTu M	7	9/39	KT3112	ArTu M	3,9	9/39	KT5111	ArTu K	6,45	9/61
KO1201	ArTu K	7	9/63	KT3112	ArTu K	3,9	9/60	KT5112	ArTu M	5,8	9/39
KO1201	ArTu K	7	9/60	KT3114	ArTu K	5	9/61	KT5112	ArTu K	5,8	9/60
KO1251	ArTu K	20,5	9/63	KT3115	ArTu K	5,6	9/65	KT5117	ArTu K	9,85	9/62
KO1260	ArTu L	4,78	9/20	KT3116	ArTu K	4,5	9/61	KT5120	ArTu K	4,74	9/61
KO1261	ArTu L	4,78	9/20	KT3118	ArTu M	3,13	9/39	KT5121	ArTu K	4,74	9/61
KO1262	ArTu L	3,08	9/20	KT3119	ArTu K	3,89	9/61	KT5122	ArTu K	2,68	9/65
KO1280	ArTu L	6,59	9/20	KT3120	ArTu K	5,6	9/65	KT5123	ArTu K	11,25	9/66
KO1281	ArTu L	6,59	9/20	KT3121	ArTu K	5,82	9/61	KT5124	ArTu K	8,44	9/66
KO2260	ArTu M	6,31	9/39	KT3124	ArTu K	5,6	9/65	KT5125	ArTu K	7,58	9/66
KO2260	ArTu K	6,31	9/63	KT3131	ArTu K	11,41	9/61	KT5126	ArTu K	5,63	9/66
KO2260	ArTu K	6,31	9/60	KT3132	ArTu K	10,57	9/65	KT5128	ArTu K	10,25	9/66
KO2261	ArTu M	6,31	9/39	KT3211	ArTu K	7,53	9/62	KT5129	ArTu K	8,44	9/66
KO2261	ArTu K	6,31	9/63	KT3212	ArTu M	5,6	9/39	KT5130	ArTu K	4,92	9/61
KO2261	ArTu K	6,31	9/60	KT3212	ArTu K	5,6	9/60	KT5131	ArTu K	4,92	9/61
KO2280	ArTu M	8,18	9/39	KT3221	ArTu K	7,53	9/62	KT5134	ArTu K	6,33	9/61
KO2280	ArTu K	8,18	9/63	KT3401	ArTu K	3,6	9/61	KT5135	ArTu K	6,33	9/61
KO2280	ArTu K	8,18	9/60	KT3410	ArTu K	4	9/65	KT5136	ArTu K	5,89	9/65
KO2281	ArTu M	8,18	9/39	KT3416	ArTu K	5,02	9/62	KT5137	ArTu K	9,5	9/66
KO2281	ArTu K	8,18	9/63	KT3419	ArTu K	3,6	9/61	KT5138	ArTu K	8,44	9/62
KO2281	ArTu K	8,18	9/60	KT3420	ArTu K	4	9/65	KT5139	ArTu K	10,55	9/62
KO3660	ArTu K	8,23	9/63	KT3421	ArTu K	3,88	9/61	KT5211	ArTu K	9,5	9/62
KO3680	ArTu K	10,83	9/63	KT3426	ArTu K	5,02	9/62	KT5212	ArTu M	8,25	9/39
KS....				KT4101	ArTu K	3,16	9/61	KT5212	ArTu K	8,25	9/60
KS8210	ArTu K	19,36	9/66	KT4102	ArTu M	11,56	9/39	KT5214	ArTu K	9,85	9/62
KS8211	ArTu K	18,45	9/62	KT4102	ArTu K	11,56	9/60	KT5221	ArTu K	10,55	9/62
KT....				KT4103	ArTu K	11,16	9/62	KT5222	ArTu K	8,44	9/62
KT1100	ArTu K	3,89	9/65	KT4110	ArTu M	2,95	9/39	KT5223	ArTu K	11,25	9/66
KT1101	ArTu K	5,64	9/61	KT4110	ArTu K	2,95	9/60	KT5231	ArTu K	10,55	9/62
KT1102	ArTu M	4	9/39	KT4111	ArTu K	2,95	9/61	KT5232	ArTu K	8,44	9/62
KT1102	ArTu K	4	9/60	KT4112	ArTu M	2,8	9/39	KT5310	ArTu K	14,77	9/65
KT1110	ArTu K	3,89	9/65	KT4112	ArTu K	2,8	9/60	KT5320	ArTu K	14,77	9/65
KT1111	ArTu K	3,89	9/61	KT4113	ArTu K	3,16	9/65	KT5321	ArTu K	14,77	9/65
KT1112	ArTu K	5,97	9/61	KT4116	ArTu K	7,83	9/62	KT5401	ArTu K	7,71	9/62
KT1117	ArTu M	3,89	9/39	KT4120	ArTu K	1,87	9/65	KT5411	ArTu K	2,65	9/61
KT1117	ArTu K	3,89	9/60	KT4121	ArTu K	11,37	9/66	KT5412	ArTu K	3,66	9/62
KT1401	ArTu K	3,76	9/61	KT4122	ArTu K	2,95	9/61	KT5420	ArTu K	4,89	9/65
KT1410	ArTu K	2,59	9/65	KT4124	ArTu K	2,35	9/65	KT5421	ArTu K	4,58	9/65
				KT4125	ArTu K	6,33	9/61	KT5430	ArTu K	4,92	9/65

List of codes

Code	Structure	Weight (Kg)	Page	Code	Structure	Weight (Kg)	Page	Code	Structure	Weight (Kg)	Page
KT5431	ArTu K	4,92	9/65	KX4602	ArTu M-K	11,56	9/39-60	KY4141	ArTu K	22,45	9/65
KT6110	ArTu K	9,53	9/65	KX3609	ArTu M-K	5,64	9/39-60	LA....			
KT6111	ArTu K	9,53	9/61	KX1419	ArTu K	3,6	9/61	LA1810	ArTu K	52,5	9/52
KT6112	ArTu K	10,25	9/61	KX1611	ArTu K	3,89	9/61	LA1860	ArTu K	31	9/52
KT6113	ArTu M	9,53	9/39	KX1609	ArTu K	5,64	9/61	LA1880	ArTu K	42	9/52
KT6113	ArTu K	9,53	9/60	KX1801	ArTu K	7,52	9/61	LA2010	ArTu K	52	9/52
KT6114	ArTu K	10,65	9/61	KX2411	ArTu K	3,6	9/61	LA2060	ArTu K	44	9/52
KT6115	ArTu K	9,53	9/61	KX2611	ArTu K	3,89	9/61	LA2080	ArTu K	47	9/52
KT6116	ArTu K	15,25	9/61	KX2601	ArTu K	5,4	9/61	LF....			
KT6117	ArTu K	15,25	9/61	KX2801	ArTu K	7,2	9/61	LF1400	ArTu L	10,17	9/14
KT6118	ArTu K	15,25	9/61	KX2621	ArTu K	3,89	9/61	LF1425	ArTu M	9,5	9/33
KT6119	ArTu K	15,25	9/61	KX3411	ArTu K	3,6	9/61	LF1600	ArTu L	11,61	9/14
KT6120	ArTu K	9,53	9/62	KX3611	ArTu K	3,89	9/61	LF1625	ArTu M	10,8	9/33
KT6121	ArTu K	9,53	9/62	KX3811	ArTu K	7,76	9/61	LF1626	ArTu K	12,1	9/52
KT6122	ArTu K	9,53	9/62	KX3601	ArTu K	5,4	9/61	LF1800	ArTu L	13,05	9/14
KT6123	ArTu K	9,53	9/62	KX3801	ArTu K	7,2	9/61	LF1810	ArTu K	55	9/52
KT6130	ArTu K	9,53	9/65	KX3621	ArTu K	5,82	9/61	LF1825	ArTu M	12	9/33
KT6131	ArTu K	9,53	9/61	KX4411	ArTu K	2,95	9/61	LF1826	ArTu K	13,5	9/52
KT6132	ArTu K	9,53	9/66	KX4611	ArTu K	2,95	9/61	LF1840	ArTu K	19	9/52
KT6133	ArTu K	9,53	9/66	KX4622	ArTu K	2,95	9/61	LF1850	ArTu K	22,30	9/52
KT6134	ArTu K	9,53	9/65	KX4627	ArTu K	6,33	9/61	LF1860	ArTu K	35	9/52
KT6141	ArTu K	9,53	9/66	KX4601	ArTu K	3,16	9/61	LF1880	ArTu K	44	9/52
KT6142	ArTu K	15,25	9/65	KX3412	ArTu K	5,02	9/62	LF2000	ArTu L	14,50	9/14
KT6143	ArTu K	15,25	9/65	KX3613	ArTu K	4,95	9/62	LF2010	ArTu K	52	9/52
KT6144	ArTu K	15,25	9/65	KX3812	ArTu K	10,04	9/62	LF2025	ArTu M	13,5	9/33
KT6145	ArTu K	15,25	9/65	KX4412	ArTu K	4,66	9/62	LF2026	ArTu K	15	9/52
KT6210	ArTu K	9,53	9/66	KX4617	ArTu K	8,7	9/62	LF2040	ArTu K	19,5	9/52
KT6211	ArTu K	9,53	9/62	KX4616	ArTu K	7,83	9/62	LF2050	ArTu K	24,78	9/52
KT6213	ArTu M	9,53	9/39	KX4818	ArTu K	10,44	9/62	LF2060	ArTu K	25	9/52
KT6213	ArTu K	9,53	9/60	KX4603	ArTu K	11,16	9/62	LF2080	ArTu K	47	9/52
KT6220	ArTu K	9,53	9/65	KX1605	ArTu K	5,97	9/61	LI....			
KT6221	ArTu K	9,53	9/65	KX2605	ArTu K	3,2	9/61	LI1840	ArTu K	23	9/52
KT6230	ArTu K	9,53	9/66	KX3605	ArTu K	5	9/61	LI1860	ArTu K	28	9/52
KT7110	ArTu K	5,78	9/61	KX1131	ArTu K	5,64	9/61	LI1880	ArTu K	33	9/52
KT7111	ArTu K	8,10	9/61	KX3131	ArTu K	11,41	9/61	LI2040	ArTu K	26	9/52
KT7115	ArTu K	10,41	9/65	KX4141	ArTu K	12,65	9/61	LI2060	ArTu K	30	9/52
KT7211	ArTu K	10,91	9/62	KY....			LI2080	ArTu K	35	9/52	
KT7211	ArTu K	10,91	9/62	KY1411	ArTu K	2,59	9/65	LK....			
KT7215	ArTu K	11,65	9/66	KY1611	ArTu K	3,89	9/65	LK1000	ArTu L	3,39	9/21
KT7230	ArTu K	20,92	9/66	KY1601	ArTu K	3,89	9/65	LK1001	ArTu L	3,39	9/21
KT7230	ArTu K	20,92	9/66	KY2411	ArTu K	2,8	9/65	LK1002	ArTu L	2,64	9/21
KT7231	ArTu K	8,98	9/62	KY2611	ArTu K	3,9	9/65	LK1004	ArTu L	3,39	9/21
KT7231	ArTu K	8,98	9/62	KY2421	ArTu K	2,7	9/65	LK1008	ArTu L	4,03	9/21
KX....				KY2621	ArTu K	3,9	9/65	LK1100	ArTu L	4,52	9/21
KX1617	ArTu M-K	3,89	9/39-60	KY3411	ArTu K	4	9/65	LK1101	ArTu L	4,52	9/21
KX1602	ArTu M-K	4	9/39-60	KY3611	ArTu K	5,6	9/65	LK1104	ArTu L	4,76	9/21
KX2619	ArTu M-K	3,89	9/39-60	KY3421	ArTu K	4	9/65	LK2000	ArTu L	3,44	9/21
KX2602	ArTu M-K	4	9/39-60	KY3621	ArTu K	5,6	9/65	LK2001	ArTu L	3,39	9/21
KX3612	ArTu M-K	3,9	9/39-60	KY4411	ArTu K	1,87	9/65	LK2002	ArTu L	2,64	9/21
KX3602	ArTu M-K	5,6	9/39-60	KY4611	ArTu K	2,35	9/65	LK2004	ArTu L	3,39	9/21
KX3603	ArTu M-K	7,1	9/39-60	KY4621	ArTu K	3,16	9/65	LK2008	ArTu L	4,11	9/21
KX3618	ArTu M	3,13	9/39	KY4631	ArTu K	4,74	9/65	LK2100	ArTu L	4,58	9/21
KX4612	ArTu M-K	2,8	9/39-60	KY4412	ArTu K	9,5	9/66	LK2101	ArTu L	4,62	9/21
KX4615	ArTu M-K	6,55	9/39-60	KY4612	ArTu K	11,37	9/66	LK2104	ArTu L	4,85	9/21
KX4610	ArTu M-K	2,95	9/39-60	KY2605	ArTu K	3,89	9/65	LK3000	ArTu L	3,45	9/21
KX1618	ArTu M-K	5,64	9/39-60	KY3605	ArTu K	5,6	9/65	LK3001	ArTu L	3,39	9/21
KX1603	ArTu M-K	5,64	9/39-60	KY1131	ArTu K	10,57	9/65	LK3002	ArTu L	3,28	9/21
KX1604	ArTu M-K	5,64	9/39-60	KY3131	ArTu K	10,57	9/65				
KX3614	ArTu M-K	5,6	9/39-60	KY4604	ArTu K	9,84	9/65				
KX4614	ArTu M-K	9,25	9/39-60								

List of codes

Code	Structure	Weight (Kg)	Page	Code	Structure	Weight (Kg)	Page	Code	Structure	Weight (Kg)	Page
LK3003	ArTu L	3,58	9/21	LX3005	ArTu L	5,09	9/21	PC1400	ArTu K	0,64	9/59
LK3004	ArTu L	5,09	9/21	LX3105	ArTu L	9,23	9/21	PC1401	ArTu L	14,38	9/15
LK3005	ArTu L	5,09	9/21	LX3008	ArTu L	1,82	9/21	PC1402	ArTu L	8,37	9/15
LK3008	ArTu L	1,82	9/21	LX3300	ArTu L	4,57	9/21	PC1403	ArTu L	0,38	9/20
LK3101	ArTu L	6,79	9/21	LX4005	ArTu L	6,43	9/21	PC1436	ArTu L	18,48	9/15
LK3102	ArTu L	9,23	9/21	LX4007	ArTu L	4,11	9/21	PC1580	ArTu L	2,22	9/20
LK3104	ArTu L	6,79	9/21	LX4006	ArTu L	7,26	9/21	PC1600	ArTu L	0,96	9/20
LK3105	ArTu L	9,23	9/21	MC....				PC1600	ArTu M	0,96	9/38
LK3110	ArTu L	4,60	9/21	MC0600	ArTu L	3,69	9/12	PC1600	ArTu K	0,96	9/59
LK3111	ArTu L	4,68	9/21	MC0800	ArTu L	4,92	9/12	PC1601	ArTu L	16,32	9/15
LK3200	ArTu L	3,51	9/21	MC1000	ArTu L	6,15	9/12	PC1602	ArTu L	9,5	9/15
LK3300	ArTu L	4,57	9/21	MC1200	ArTu L	7,38	9/12	PC1636	ArTu L	20,98	9/15
LK3301	ArTu L	3,66	9/21	MC1400	ArTu L	8,61	9/14	PC1660	ArTu L	13,5	9/20
LK4003	ArTu L	3,28	9/21	MC1600	ArTu L	9,85	9/14	PC1660	ArTu M	13,5	9/38
LK4004	ArTu L	3,28	9/21	MC1800	ArTu L	11,09	9/14	PC1660	ArTu K	13,5	9/59
LK4005	ArTu L	6,43	9/21	MC2000	ArTu L	12,32	9/14	PC1680	ArTu L	18,3	9/20
LK4006	ArTu L	7,26	9/21	MI....				PC1680	ArTu M	18,3	9/38
LK4007	ArTu L	4,11	9/21	MI0600	ArTu L	1,67	9/12	PC1800	ArTu L	1,27	9/20
LK4100	ArTu L	3,44	9/21	MI0800	ArTu L	2,32	9/12	PC1800	ArTu M	1,27	9/38
LK4103	ArTu L	4,37	9/21	MI1000	ArTu L	2,79	9/12	PC1800	ArTu K	1,27	9/59
LK4104	ArTu L	4,37	9/21	MI1200	ArTu L	3,34	9/12	PC1800	ArTu L	18,26	9/15
LK4105	ArTu L	8,75	9/21	MI1400	ArTu L	3,90	9/13	PC1802	ArTu L	10,64	9/15
LK4106	ArTu L	9,69	9/21	MI1600	ArTu L	4,45	9/13	PC1836	ArTu L	23,53	9/15
LK4108	ArTu L	4,58	9/21	MI1800	ArTu L	5,02	9/13	PC1840	ArTu K	10	9/59
LK5003	ArTu L	4,51	9/21	MI2000	ArTu L	5,57	9/13	PC1860	ArTu L	15	9/20
LK5004	ArTu L	4,51	9/21	PA....				PC1860	ArTu M	15	9/38
LK5005	ArTu L	6,53	9/21	PA1600	ArTu L	2,6	9/20	PC1860	ArTu K	15	9/59
LK5006	ArTu L	7,11	9/21	PA1600	ArTu M	2,6	9/38	PC1880	ArTu L	19	9/20
LK5007	ArTu L	4,11	9/21	PA1600	ArTu K	2,6	9/59	PC1880	ArTu M	19	9/38
LK5008	ArTu L	3,47	9/21	PA2600	ArTu L	2,94	9/20	PC1880	ArTu K	19	9/59
LK5103	ArTu L	6,01	9/21	PA2600	ArTu M	2,94	9/38	PC2001	ArTu L	20,28	9/15
LK5104	ArTu L	5,76	9/21	PA2600	ArTu K	2,94	9/59	PC2002	ArTu L	11,82	9/15
LK5105	ArTu L	8,70	9/21	PB....				PC2035	ArTu L	26,07	9/15
LK5106	ArTu L	9,69	9/21	PB0802	ArTu L	0,66	9/22	PC2040	ArTu K	11,5	9/59
LK6011	ArTu L	7,09	9/21	PB0802	ArTu M	0,66	9/40	PC2060	ArTu L	16	9/20
LK6012	ArTu L	9,45	9/21	PB0802	ArTu K	0,66	9/69	PC2060	ArTu M	16	9/38
LX....				PB0803	ArTu L	0,4	9/22	PC2060	ArTu K	16	9/59
LX1000	ArTu L	3,39	9/21	PB0803	ArTu M	0,4	9/40	PC2080	ArTu L	21	9/20
LX1100	ArTu L	4,52	9/21	PB0803	ArTu K	0,4	9/69	PC2080	ArTu M	21	9/38
LX1005	ArTu L	3,39	9/21	PB1600	ArTu K	1,55	9/69	PC2080	ArTu K	21	9/59
LX1104	ArTu L	4,76	9/21	PB1601	ArTu K	1,12	9/69	PC2400	ArTu K	1,27	9/59
LX2000	ArTu L	3,44	9/21	PB1603	ArTu K	1,11	9/69	PC2401	ArTu L	0,61	9/20
LX2004	ArTu L	3,39	9/21	PB3201	ArTu K	1,11	9/69	PC2600	ArTu L	1	9/20
LX3000	ArTu L	3,45	9/21	PC....				PC2600	ArTu M	1	9/38
LX3110	ArTu L	4,6	9/21	PC0300	ArTu L	1,49	9/20	PC2600	ArTu K	1	9/59
LX3003	ArTu L	3,58	9/21	PC0580	ArTu L	0,74	9/20	PC2800	ArTu L	2,6	9/20
LX3004	ArTu L	5,09	9/21	PC0600	ArTu L	3,20	9/20	PC2800	ArTu M	2,6	9/38
LX3104	ArTu L	6,79	9/21	PC0601	ArTu L	6,16	9/15	PC2800	ArTu K	2,6	9/59
LX4003	ArTu L	3,28	9/21	PC0602	ArTu L	3,44	9/15	PC3400	ArTu K	1,57	9/59
LX4004	ArTu L	3,28	9/21	PC0801	ArTu L	8,21	9/15	PC3401	ArTu L	1,04	9/20
LX1001	ArTu L	3,39	9/21	PC0802	ArTu L	4,59	9/15	PC3600	ArTu L	1,96	9/20
LX1101	ArTu L	4,52	9/21	PC1001	ArTu L	10,27	9/15	PC3600	ArTu M	1,96	9/38
LX1002	ArTu L	2,64	9/21	PC1002	ArTu L	5,74	9/15	PC3600	ArTu K	1,96	9/59
LX1006	ArTu L	4,52	9/21	PC1050	ArTu L	0,45	9/20	PC3800	ArTu L	3,23	9/20
LX1108	ArTu L	4,52	9/21	PC1150	ArTu L	1,13	9/20	PC3800	ArTu M	3,23	9/38
LX1008	ArTu L	4,03	9/21	PC1201	ArTu L	12,32	9/15				
LX4100	ArTu L	3,44	9/21	PC1202	ArTu L	7,18	9/15				
LX3001	ArTu L	3,39	9/21								
LX3101	ArTu L	6,79	9/21								
LX3002	ArTu L	3,28	9/21								

List of codes

Code	Structure	Weight (Kg)	Page	Code	Structure	Weight (Kg)	Page	Code	Structure	Weight (Kg)	Page
PC3800	ArTu K	3,23	9/59	PF4601	ArTu K	5,6	9/63	PM6672	ArTu K	4,41	9/57
PC4400	ArTu K	2,06	9/59	PF4610	ArTu M	4,5	9/38	PO....			
PC4401	ArTu L	1,36	9/20	PF4610	ArTu K	4,5	9/60	PO1060	ArTu M	12	9/34
PC4600	ArTu L	2,45	9/20	PF4801	ArTu K	9	9/63	PO1260	ArTu M	13	9/34
PC4600	ArTu M	2,45	9/38	PF4805	ArTu K	6,2	9/64	PO1431	ArTu L	6,02	9/15
PC4600	ArTu K	2,45	9/59	PF4810	ArTu M	7,5	9/38	PO1460	ArTu M	15,5	9/34
PC4800	ArTu L	4,41	9/20	PF4810	ArTu K	7,5	9/60	PO1630	ArTu M	14	9/34
PC4800	ArTu M	4,41	9/38	PF6005	ArTu K	8,25	9/64	PO1631	ArTu L	12	9/15
PC4800	ArTu K	4,41	9/59	PF6401	ArTu K	7	9/63	PO1631	ArTu M	12	9/33
PC6400	ArTu K	3,43	9/59	PF6405	ArTu K	5,9	9/64	PO1631	ArTu K	12	9/56
PC6401	ArTu L	2,05	9/20	PF6601	ArTu K	9,5	9/63	PO1633	ArTu K	14,6	9/56
PC6600	ArTu L	4,41	9/20	PF6801	ArTu K	11	9/63	PO1660	ArTu M	17,5	9/34
PC6600	ArTu M	4,41	9/38	PF6805	ArTu K	9,1	9/64	PO1661	ArTu K	18,63	9/53
PC6600	ArTu K	4,41	9/59	PF8005	ArTu K	12,5	9/64	PO1680	ArTu M	22	9/34
PC6800	ArTu L	6,37	9/20	PF8805	ArTu K	12,4	9/64	PO1681	ArTu K	23,6	9/53
PC6800	ArTu M	6,37	9/38	PM....				PO1830	ArTu M	13	9/34
PC6800	ArTu K	6,37	9/59	PM1500	ArTu L	1,13	9/19	PO1831	ArTu L	8	9/15
PC6800	ArTu K	6,37	9/59	PM1500	ArTu K	1,13	9/57	PO1831	ArTu M	8	9/33
PC8401	ArTu L	2,67	9/20	PM1536	ArTu L	1,47	9/19	PO1831	ArTu K	8	9/56
PC8600	ArTu L	5,39	9/20	PM1536	ArTu K	1,47	9/57	PO1833	ArTu K	13	9/56
PC8600	ArTu M	5,39	9/38	PM2312	ArTu L	2,93	9/19	PO1841	ArTu K	15,2	9/53
PC8600	ArTu K	5,39	9/59	PM2312	ArTu M	2,93	9/36	PO1860	ArTu M	19	9/34
PC8800	ArTu L	8,58	9/20	PM2312	ArTu K	2,93	9/57	PO1861	ArTu K	20,5	9/53
PC8800	ArTu M	8,58	9/38	PM2315	ArTu L	3,9	9/19	PO1880	ArTu M	23	9/34
PC8800	ArTu K	8,58	9/59	PM2315	ArTu M	3,9	9/36	PO1881	ArTu K	24	9/53
PF....				PM2315	ArTu K	3,9	9/57	PO2030	ArTu M	14	9/34
PF1002	ArTu L	1,45	9/20	PM2424	ArTu K	1,67	9/57	PO2031	ArTu L	9	9/15
PF1003	ArTu L	2,23	9/20	PM2624	ArTu L	1,2	9/19	PO2031	ArTu M	9	9/33
PF1004	ArTu L	3,02	9/20	PM2624	ArTu L	1,2	9/27	PO2031	ArTu K	9	9/56
PF1006	ArTu L	4,58	9/20	PM2624	ArTu M	1,2	9/36	PO2033	ArTu K	9	9/56
PF1008	ArTu L	6,33	9/20	PM2624	ArTu M	1,2	9/45	PO2041	ArTu K	16,2	9/53
PF1102	ArTu L	1,94	9/20	PM2624	ArTu K	1,2	9/57	PO2060	ArTu M	22	9/34
PF1103	ArTu L	2,98	9/20	PM2624	ArTu K	1,2	9/77	PO2061	ArTu K	22	9/53
PF1104	ArTu L	4,03	9/20	PM2836	ArTu L	2	9/19	PO2080	ArTu M	26	9/34
PF1106	ArTu L	6,10	9/20	PM2836	ArTu L	2	9/27	PO2081	ArTu K	28	9/53
PF1108	ArTu L	8,44	9/20	PM2836	ArTu M	2	9/36	PO6060	ArTu M	7,5	9/34
PF1806	ArTu K	25	9/63	PM2836	ArTu M	2	9/45	PO6069	ArTu M	10	9/50
PF1808	ArTu K	32	9/63	PM2836	ArTu M	2	9/57	PO8060	ArTu M	10	9/34
PF2005	ArTu K	2,5	9/64	PM2836	ArTu K	2	9/77	PR....			
PF2006	ArTu K	35,5	9/63	PM3424	ArTu K	1,41	9/57	PR2600	ArTu L	1,96	9/20
PF2008	ArTu K	36	9/63	PM3624	ArTu L	2,87	9/19	PR2600	ArTu M	1,96	9/38
PF2401	ArTu K	1,8	9/63	PM3624	ArTu L	2,87	9/26	PR2600	ArTu K	1,96	9/59
PF2405	ArTu K	1,8	9/64	PM3624	ArTu M	2,87	9/36	PR2800	ArTu L	2,74	9/20
PF2601	ArTu K	2,5	9/63	PM3624	ArTu M	2,87	9/44	PR2800	ArTu M	2,74	9/38
PF2610	ArTu M	2,5	9/38	PM3624	ArTu M	2,87	9/44	PR2800	ArTu K	2,74	9/59
PF2610	ArTu K	2,5	9/60	PM3624	ArTu M	2,87	9/57	PR4401	ArTu L	1,61	9/20
PF2801	ArTu K	3,6	9/63	PM3624	ArTu K	2,87	9/76	PR4600	ArTu L	3,92	9/20
PF2805	ArTu K	3,2	9/64	PM3648	ArTu L	2,87	9/19	PR4600	ArTu M	3,92	9/38
PF2810	ArTu M	3,6	9/38	PM3648	ArTu M	2,87	9/36	PR4600	ArTu K	3,92	9/59
PF2810	ArTu K	3,6	9/60	PM3648	ArTu K	2,87	9/36	PR4800	ArTu L	4,12	9/20
PF3005	ArTu K	4,6	9/64	PM3836	ArTu L	3,82	9/19	PR4800	ArTu M	4,12	9/38
PF3403	ArTu K	2,6	9/63	PM3836	ArTu L	3,82	9/26	PR4800	ArTu K	4,12	9/59
PF3405	ArTu K	2,9	9/64	PM3836	ArTu M	3,82	9/36	PR6600	ArTu L	5,39	9/20
PF3601	ArTu K	4,6	9/63	PM3836	ArTu M	3,82	9/44	PR6600	ArTu M	5,39	9/38
PF3801	ArTu K	6	9/63	PM3836	ArTu M	3,82	9/57	PR6600	ArTu K	5,39	9/59
PF3805	ArTu K	4,6	9/64	PM3836	ArTu K	3,82	9/57	PR6800	ArTu L	6,86	9/20
PF4005	ArTu K	5,6	9/64	PM3836	ArTu K	3,82	9/76	PR6800	ArTu M	6,86	9/38
PF4401	ArTu K	4,1	9/63	PM3872	ArTu L	3,82	9/19	PR6800	ArTu K	6,86	9/59
PF4405	ArTu K	3,6	9/64	PM3872	ArTu M	3,82	9/36	PS....			
				PM3872	ArTu M	3,82	9/36	PS2720	ArTu L	1,27	9/19
				PM3872	ArTu K	3,82	9/57	PS2720	ArTu M	1,27	9/36
				PM6672	ArTu L	4,41	9/19	PS2720	ArTu K	1,27	9/57
				PM6672	ArTu M	4,41	9/36				

List of codes

Code	Structure	Weight (Kg)	Page	Code	Structure	Weight (Kg)	Page	Code	Structure	Weight (Kg)	Page
PS2728	ArTu L	2,45	9/19	PV2081	ArTu K	30,45	9/53	SK2002	ArTu K	16,46	9/52
PS2728	ArTu M	2,45	9/36	PV2082	ArTu K	32	9/53	SK2003	ArTu K	10	9/52
PS2728	ArTu K	2,45	9/57	PV2083	ArTu K	32	9/53	SK2004	ArTu K	9,5	9/52
PS2960	ArTu L	1,27	9/19	PV2088	ArTu M	38	9/34	SK2015	ArTu K	21,7	9/51
PS2960	ArTu M	1,27	9/36	PV4060	ArTu M	7	9/50	SK2080	ArTu K	5,2	9/55
PS2960	ArTu K	1,27	9/57	PV6060	ArTu M	7	9/34	SK2081	ArTu K	4,35	9/67
PS2968	ArTu L	2,45	9/19	PV8060	ArTu M	9	9/34	SK4010	ArTu K	35	9/51
PS2968	ArTu M	2,45	9/36	RC....				SK4040	ArTu K	20,5	9/51
PS2968	ArTu K	2,45	9/57	RC1000	ArTu L	14,41	9/17	SK4050	ArTu K	28,85	9/51
PS4720	ArTu L	1,27	9/19	RC2000	ArTu L	10,19	9/17	SK4060	ArTu K	30,3	9/51
PS4720	ArTu M	1,27	9/36	RF....				SK4080	ArTu K	36	9/51
PS4720	ArTu K	1,27	9/57	RF1630	ArTu K	10,8	9/56	SK6010	ArTu K	52,5	9/51
PS4728	ArTu L	2,45	9/19	RF1660	ArTu K	18,2	9/54	SK6025	ArTu K	23,8	9/51
PS4728	ArTu M	2,45	9/36	RF1680	ArTu K	23,2	9/54	SK6040	ArTu K	30,3	9/51
PS4728	ArTu K	2,45	9/57	RF1830	ArTu K	10,5	9/56	SK6050	ArTu K	36,54	9/51
PS4960	ArTu L	1,3	9/19	RF1840	ArTu K	15,5	9/54	SK6060	ArTu K	41,6	9/51
PS4960	ArTu M	1,3	9/36	RF1860	ArTu K	20,5	9/54	SK6080	ArTu K	46,5	9/51
PS4960	ArTu K	1,3	9/57	RF1880	ArTu K	24	9/54	SK6600	ArTu K	41,6	9/51
PS4968	ArTu L	2,5	9/19	RF2030	ArTu K	11,5	9/56	SK8010	ArTu K	62,5	9/51
PS4968	ArTu M	2,5	9/36	RF2040	ArTu K	16,8	9/54	SK8025	ArTu K	28,28	9/51
PS4968	ArTu K	2,5	9/57	RF2060	ArTu K	20,66	9/54	SK8040	ArTu K	36	9/51
PV....				RF2080	ArTu K	26,56	9/54	SK8050	ArTu K	44,84	9/51
PV0600	ArTu L	6,16	9/15	SA....				SK8060	ArTu K	49,5	9/51
PV0800	ArTu L	8,21	9/15	SA1350	ArTu M	2,2	9/46	SK8080	ArTu K	57,5	9/51
PV1000	ArTu L	10,27	9/15	SA1350	ArTu K	2,2	9/78	SK8800	ArTu K	57,5	9/51
PV1060	ArTu M	10,5	9/34	SH....				SL....			
PV1260	ArTu M	12	9/34	SH0100	ArTu L	1,16	9/16	SL0600	ArTu L	9,84	9/12
PV1400	ArTu L	14,38	9/15	SH0200	ArTu L	1,42	9/16	SL0800	ArTu L	13,12	9/12
PV1424	ArTu L	19,48	9/15	SH0208	ArTu L	1,82	9/16	SL1000	ArTu L	16,40	9/12
PV1436	ArTu L	19,98	9/15	SH0600	ArTu L	0,52	9/16	SL1200	ArTu L	19,67	9/12
PV1460	ArTu M	15	9/34	SH0608	ArTu L	1,26	9/16	SL1400	ArTu L	22,49	9/13
PV1600	ArTu L	16,32	9/15	SH0700	ArTu L	0,46	9/16	SL1408	ArTu L	28,92	9/13
PV1624	ArTu L	22,17	9/15	SH0708	ArTu L	1,12	9/16	SL1600	ArTu L	24,95	9/13
PV1636	ArTu L	22,67	9/15	SH0800	ArTu L	0,69	9/16	SL1608	ArTu L	33,05	9/13
PV1660	ArTu M	17	9/34	SH0808	ArTu L	1,67	9/16	SL1800	ArTu L	27,9	9/13
PV1661	ArTu K	18,6	9/53	SH1030	ArTu K	2,94	9/68	SL1808	ArTu L	37,19	9/13
PV1680	ArTu M	21,5	9/34	SH2030	ArTu K	2,45	9/68	SL2000	ArTu L	31,1	9/13
PV1681	ArTu K	23,60	9/53	SH4000	ArTu K	2	9/68	SL2008	ArTu L	41,32	9/13
PV1682	ArTu K	23,60	9/53	SH4030	ArTu K	3,3	9/68	SM....			
PV1688	ArTu M	32	9/34	SH4031	ArTu K	3,15	9/68	SM1062	ArTu M	23,5	9/32
PV1800	ArTu L	18,26	9/15	SH4033	ArTu K	5,31	9/68	SM1069	ArTu M	31,5	9/32
PV1824	ArTu L	24,86	9/15	SH4034	ArTu K	6,49	9/68	SM1262	ArTu M	26,5	9/32
PV1836	ArTu L	25,36	9/15	SH4035	ArTu K	9,23	9/68	SM1462	ArTu M	40,96	9/33
PV1841	ArTu K	14,3	9/53	SH6000	ArTu K	2,65	9/68	SM1662	ArTu M	44,69	9/33
PV1860	ArTu M	19,5	9/34	SH6001	ArTu M	2,7	9/47	SM1862	ArTu M	48,51	9/33
PV1861	ArTu K	19,5	9/53	SH8000	ArTu K	1,9	9/68	SM2062	ArTu M	52,43	9/33
PV1863	ArTu K	24,2	9/53	SH8001	ArTu M	3,7	9/47	SM6061	ArTu M	15,3	9/32
PV1880	ArTu M	24,2	9/34	SK....				SM8061	ArTu M	18,4	9/32
PV1881	ArTu K	24,20	9/53	SK1600	ArTu K	16,72	9/51	SM8062	ArTu M	20	9/32
PV1882	ArTu K	35	9/53	SK1604	ArTu K	6,75	9/52	SV....			
PV1883	ArTu K	28,2	9/53	SK1800	ArTu K	19	9/51	SV0600	ArTu L	1,25	9/16
PV1888	ArTu M	35	9/34	SK1802	ArTu K	15,19	9/52	SV0800	ArTu L	1,66	9/16
PV2000	ArTu L	20,29	9/15	SK1803	ArTu K	9,5	9/52	SV1000	ArTu L	2,08	9/16
PV2024	ArTu L	27,55	9/15	SK1804	ArTu K	8	9/52	SV1200	ArTu L	2,49	9/16
PV2036	ArTu L	28,05	9/15	SK1815	ArTu K	19,42	9/51	SV1400	ArTu L	2,91	9/16
PV2041	ArTu K	15,8	9/53	SK1880	ArTu K	4,5	9/55	SV1600	ArTu L	3,33	9/16
PV2060	ArTu M	21,5	9/34	SK1881	ArTu K	3,97	9/67	SV1800	ArTu L	3,74	9/16
PV2061	ArTu K	21,5	9/53	SK2000	ArTu K	20,8	9/51	SV1815	ArTu K	14,63	9/68
PV2063	ArTu K	28,2	9/53					SV1860	ArTu K	7,2	9/68
PV2080	ArTu M	27	9/34								

List of codes

Code	Structure	Weight (Kg)	Page	Code	Structure	Weight (Kg)	Page	Code	Structure	Weight (Kg)	Page
SV1880	ArTu K	11,5	9/68	TS....				VB7035	ArTu K	0,6	9/82
SV2000	ArTu L	4,16	9/16	TS4011	ArTu L	2	9/29	VC....			
SV2015	ArTu K	16,25	9/68	TS4011	ArTu M	2	9/48	VC0600	ArTu L	5,74	9/12
SV2061	ArTu K	1,76	9/68	TS4011	ArTu K	2	9/80	VC0800	ArTu L	7,65	9/12
SV2080	ArTu K	1,26	9/68	TS4012	ArTu L	2	9/29	VC1000	ArTu L	9,56	9/12
SV2265	ArTu K	7,84	9/68	TS4012	ArTu M	2	9/48	VC1200	ArTu L	11,48	9/12
SV2285	ArTu K	12,74	9/68	TS4012	ArTu K	2	9/80	VC1400	ArTu L	13,39	9/13
SV4061	ArTu K	2,35	9/68	TS4013	ArTu L	2	9/29	VC1425	ArTu L	7,67	9/13
SV4080	ArTu K	10,1	9/68	TS4013	ArTu M	2	9/48	VC1600	ArTu L	14,66	9/13
TL....				TS4013	ArTu K	2	9/80	VC1622	ArTu M	15	9/33
TL1000	ArTu L	0,70	9/17	TU....				VC1624	ArTu K	17,5	9/55
TL1000	ArTu L	0,70	9/23	TU8000	ArTu L	1,35	9/28	VC1625	ArTu L	8,77	9/13
TL1000	ArTu L	0,70	9/24	TV....				VC1632	ArTu M	20,58	9/33
TL1100	ArTu L	0,85	9/17	TV1001	ArTu K	1,53	9/71	VC1800	ArTu L	15,90	9/13
TL1100	ArTu L	0,85	9/23	TV1005	ArTu K	2,84	9/71	VC1820	ArTu K	28,5	9/55
TL1100	ArTu L	0,85	9/24	TV1011	ArTu K	1,78	9/72	VC1822	ArTu M	16	9/33
TL2000	ArTu L	0,68	9/17	TV1101	ArTu K	1,32	9/71	VC1823	ArTu K	26	9/55
TL2000	ArTu L	0,68	9/23	TV1101	ArTu K	1,32	9/71	VC1824	ArTu K	19,5	9/55
TL2100	ArTu L	0,82	9/17	TV1211	ArTu K	6,29	9/72	VC1825	ArTu L	9,86	9/13
TL2100	ArTu L	0,82	9/23	TV1261	ArTu K	2,89	9/72	VC1832	ArTu M	22,54	9/33
TL2100	ArTu L	0,82	9/23	TV1261	ArTu K	2,89	9/74	VC2000	ArTu L	17,66	9/13
TL3000	ArTu L	0,52	9/17	TV1311	ArTu K	11,5	9/74	VC2020	ArTu K	31,5	9/55
TL3000	ArTu L	0,52	9/23	TV2000	ArTu M	0,47	9/41	VC2022	ArTu M	18	9/33
TL3000	ArTu L	0,52	9/24	TV2000	ArTu M	0,47	9/46	VC2023	ArTu K	30	9/55
TR....				TV3000	ArTu K	0,98	9/71	VC2024	ArTu K	22,9	9/55
TR1201	ArTu K	3,06	9/74	TV3101	ArTu K	0,50	9/71	VC2025	ArTu L	10,96	9/13
TR1205	ArTu K	3,45	9/74	TV3201	ArTu K	0,62	9/71	VC2032	ArTu M	29,40	9/33
TR2001	ArTu M	0,22	9/46	TV4000	ArTu K	0,98	9/71	VC3010	ArTu K	34,25	9/56
TR3001	ArTu M	0,78	9/41	TV4001	ArTu K	0,98	9/71	VC3025	ArTu K	19,25	9/56
TR3001	ArTu M	0,78	9/42	TV4221	ArTu K	0,98	9/72	VC3040	ArTu K	24,5	9/56
TR3001	ArTu M	0,78	9/46	TV5101	ArTu K	1,18	9/71	VC3050	ArTu K	26,55	9/56
TR4101	ArTu K	0,49	9/79	TV5101	ArTu K	1,18	9/79	VC3060	ArTu K	28	9/56
TR6001	ArTu K	0,78	9/74	TV6001	ArTu K	0,45	9/71	VC3080	ArTu K	29,5	9/56
TR6001	ArTu K	0,78	9/79	TV6005	ArTu K	0,49	9/71	ZD....			
TR6005	ArTu K	0,39	9/74	TV6011	ArTu K	0,73	9/72	ZD1015	ArTu K	1,30	9/51
TR6005	ArTu K	0,39	9/79	TV6101	ArTu K	0,83	9/71	ZD1025	ArTu K	1,72	9/51
TR6101	ArTu K	0,39	9/74	TV6200	ArTu M	0,46	9/41	ZD1030	ArTu K	2,19	9/51
TR6101	ArTu K	0,39	9/79	TV6200	ArTu M	0,46	9/41	ZD1050	ArTu K	3,38	9/51
TR6201	ArTu K	0,39	9/74	TV6200	ArTu M	0,46	9/42	ZD1070	ArTu K	4,57	9/51
TR6205	ArTu K	0,49	9/74	TV6201	ArTu K	0,93	9/71	ZD1090	ArTu K	5,75	9/51
TR6301	ArTu K	0,49	9/74	TV6202	ArTu K	1,96	9/71	ZD2324	ArTu K	3,8	9/78
TR7005	ArTu K	1,18	9/74	TV6203	ArTu K	0,43	9/72	ZD2325	ArTu M	3,8	9/50
TR7005	ArTu K	1,18	9/79	TV6221	ArTu K	1,08	9/72	ZD2340	ArTu K	3,8	9/78
TR8000	ArTu K	0,98	9/79	TV8001	ArTu K	0,74	9/71	ZD2350	ArTu K	6,14	9/78
TR8001	ArTu K	0,98	9/74	TV8005	ArTu K	0,78	9/71	ZD2361	ArTu K	4,2	9/78
TR8001	ArTu K	0,98	9/79	TV8011	ArTu K	1,08	9/72	ZD2381	ArTu K	4,5	9/78
TR8005	ArTu K	0,49	9/74	TV8101	ArTu K	1,13	9/71	ZD2440	ArTu K	6,7	9/78
TR8005	ArTu K	0,49	9/74	TV8200	ArTu M	0,75	9/41	ZD2450	ArTu K	6,97	9/78
TR8005	ArTu K	0,49	9/79	TV8200	ArTu M	0,75	9/41	ZD2460	ArTu K	8,1	9/78
TR8005	ArTu K	0,49	9/79	TV8201	ArTu M	0,75	9/42	ZD2480	ArTu K	11,5	9/78
TR8101	ArTu K	0,49	9/74	TV8201	ArTu K	1,22	9/71	ZD2624	ArTu K	11,4	9/78
TR8101	ArTu K	0,49	9/79	TV8202	ArTu K	2,61	9/71	ZD2625	ArTu M	8,5	9/50
TR8201	ArTu K	0,49	9/74	TV8203	ArTu K	0,58	9/72	ZD2640	ArTu K	9,2	9/78
TR8205	ArTu K	0,78	9/74	TV8211	ArTu K	1,22	9/72	ZD2650	ArTu K	10,56	9/78
TR8301	ArTu K	0,49	9/74	TV8211	ArTu K	1,22	9/74	ZD2660	ArTu K	11	9/78
TR8400	ArTu K	0,5	9/79	TV8221	ArTu K	1,39	9/72	ZD2680	ArTu K	12,61	9/78
TR8500	ArTu K	0,45	9/79	VB....				ZD2824	ArTu K	15,2	9/78
TR8600	ArTu K	0,5	9/79	VB7035	ArTu L	0,6	9/31	ZD2825	ArTu M	10	9/50
TR8800	ArTu K	0,5	9/79	VB7035	ArTu M	0,6	9/50	ZD2840	ArTu K	10,9	9/78
TR8900	ArTu K	0,62	9/79	VB7035	ArTu M	0,6	9/50				

Contact us

ABB SACE

A division of ABB S.p.A.

Automation and Distribution Boards

Via Italia, 58

23846 Garbagnate Monastero (LC) - Italy

Tel.: +39 031 3570 1

Fax: +39 031 3570228

www.abb.com

The data and illustrations are not binding. We reserve the right to modify the contents of this document on the basis of technical development of the products, without prior notice.

Copyright 2010 ABB. All rights reserved.

1STC008001D0201 - 06/2010 - 4.000