

Energy management Solutions for smart machines, factories and grids Let's connect.

Energymanagement & Monitoring Solutions



Energy management

Solutions for smart machines, factories and grids

Energy management
Solutions for smart machines,
factories and grids

Hardware

Software

Service

Contents

A

B

C

Appendix

Index

Search according to type or order number,
worldwide activities

X

Hardware

Hardware	Total Energy Monitoring	A.2
	Power Quality Monitoring	A.12
	Residual Current Monitoring	A.14
	Overview of energy meters	A.16
	Energy Meter	A.18
	Energy Analyser	A.30
	Energy Logger	A.36
	u-mation automation toolbox	A.38
	Periphery Energy Management	A.44
	Current Transformers	A.46
	Rogowski System	A.60
	Transformer Wiring	A.61
	EM-Connectivity-Box	A.62
	Industrial Ethernet	A.66

Maximum energy efficiency and plant availability

Tap new potential with Total Energy Monitoring

Total Energy Monitoring is Weidmüller's holistic modular system for measuring and monitoring the power supply network. Entire manufacturing energy networks can be continuously monitored and analysed in detail – even remotely.

Effectively maximise energy efficiency and plant availability

Climate change and dwindling resources are global megatrends that are increasingly influencing corporate action. It also holds true that if you reduce energy costs, you increase profitability. In addition, high plant availability is playing an increasingly prominent role for ensuring efficient production processes. These factors require a specific package of measurements that is individually tailored for each company.

With Total Energy Monitoring, Weidmüller has developed an equally comprehensive and flexible product range for individual solutions: hardware, software and consultancy services are tailored to fulfil the purpose of the customer-specific Energy Management solution. The concept supports also the international ISO 50001 directive and makes projects easier to plan and realise.

Seamless portfolio for plants of all sizes

Achieve full transparency of your manufacturing energy consumption. Manufacturing energy networks can be fully monitored and analysed from the interconnection point and sub-distribution all the way down to the individual machine modules. You gain a better understanding of the process and more control over your energy costs and machine processes.

The Weidmüller solution supports this optimisation process with software and hardware components which can be used flexibly. They are highly compatible, even when used in collaboration with already installed energy measurement systems and can be easily adjusted to individual application requirements. In short, you can always rely on a seamless production portfolio with optimum quality for all levels of production. The improved availability and efficiency of your entire plant will quickly become noticeable.



Expertise and awards

Weidmüller has a long tradition of energy efficiency. During the time between receiving our first award, the ASU Environmental Prize in 1990, and the GreenTec award in 2014, we have enjoyed decades of pioneering work and development. An outstanding example of accurate energy monitoring is our production location in Detmold, which was awarded the title of a climate protection company in 2013. Implemented with our proprietary components, the hardware in combination with the specialised software provides the best prerequisites for successful energy monitoring.

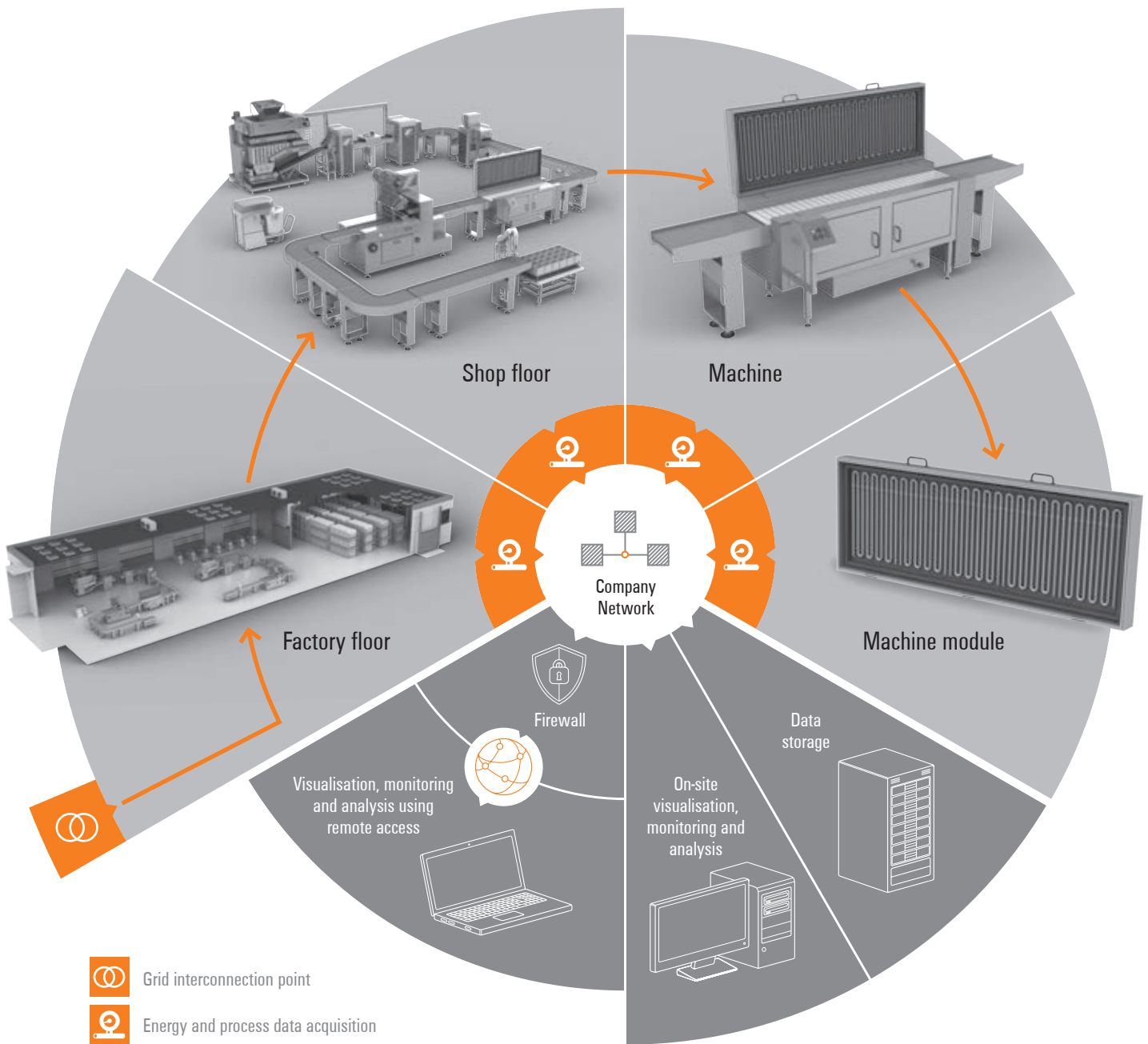

Total Energy Monitoring for all four levels of production

The Total Energy Monitoring concept ensures consistency from interconnection points in the factory, down the production lines and individual machines and into the heart of the machine processes.

The solution allows you to monitor current and energy measurement data as well as other process data relevant for energy monitoring within your entire concept, such as

flow rates, temperatures or pressures. Transferring the measurement data to a central data server allows for immediate access and prompt evaluation using the u-create ResMa software.

In addition the flexible remote maintenance solution u-link is available which provides the ability to communicate from remote into the machine module level.

Implement your own individual Energy Management system

With our integrated expertise from a single source

Energy Management is a triad of recording all relevant energy consumption data, analysing the information obtained, and comprehensive consulting on possible saving potential. We at Weidmüller see the development of an Energy Management system as a holistic task which combines expert advice with intelligent hardware and software solutions to form a strong unit which is modular in design and therefore tailored to your requirements.

Hardware components

Extraction of exact measurement data for analysis

Integrated planning of the approach

Use our comprehensive hardware portfolio of selected „Total Energy Monitoring“ components for energy consumption measurement and monitoring, integrated analysis of the quality of electrical supply networks and for efficient, convenient provision of measurement data.

Selection of suitable products, solutions and functions

- u-remote performance measurement module
- Energy meters
- Energy analysis instruments
- Energy loggers
- Measurement converter disconnecter terminals
- Current transformers
- Power supply solutions
- Connectivity
- u-mation toolbox
- Industrial communication infrastructure
- Customer-specific plug & play solutions
- Rogowski coils

Modular adaptation to your requirements

Simple, cost-effective integration into existing systems

Broad range of universal-fit connection solutions to connect existing hardware

Use of high-quality, tried and tested standard components

Well proven components that are tailored to each other from the Weidmüller standard range

Option of implementing tailored solutions

Customer-specific assembly and construction of components to meet individual requirements



Software and controlling

Determination of relevant indices for planning

Advice and design

Capable support through to certification

The software modules of the Weidmüller Energy Suite meet your requirements, from the sensor level to the cloud. Parameterise our field devices using ecoExplorer go, digitise the data using the u-create data hub, conduct standardised analyses using the u-create ResMa or forecast load peaks with the u-create energetics System. The perfect interaction between Weidmüller field devices and the components of the Weidmüller Energy Suite ensures the greatest possible predictability, even for complex requirements.

Starting with a specific demand analysis, we work on proposals for the measurement and visualisation of the energy data to be recorded and handle the detailed planning for the implementation of Energy Management. Together with you, we work out energy efficiency measures and, if desired, support the implementation process right through to the certification of your company in accordance with ISO 50001 and beyond.

- Recording process and energy data
- Registering energy and raw materials prices
- Forecasting costly load peaks
- Cost centre analyses
- Long-term data archiving
- Database interfaces for MES/SCADA systems

- Energy auditing and measuring point concepts
- Energy efficiency analyses and simulations
- Energy monitoring and controlling
- Tax and expenses optimisation
- Staff training sessions and seminars
- ISO 50001 Energy Management
- DIN EN 16247-1 energy audit
- Load profile analyses
- Monitoring grid and power quality

Compact – IPC-based entry-level solution

Record, automate and bundle measurement data on a central basis. Create transparency about energy media and draw up initial reports.

Server – Extensive scalable

Strong integration into your own infrastructure for extensive data collection. Ideal for cross-site Energy Management.

Cloud – Energy Management on a rental basis

Use intelligent data collectors in the field to evaluate your energy data easily, conveniently and safely in the cloud.

Optimisation by your own specialists

We ensure transparency - You implement the knowledge gained appropriately with your employees.

Support with achieving short-term savings

Based on the data gathered, we work with you to develop effective solutions for basic and peak load reduction.

Long-term support for lasting optimisation

You are given long-term support with the continuous optimisation of your energy use.

Energy Management in practice

Insights into Weidmüller's „transparent factory“

Weidmüller has a long tradition of handling energy and resources responsibly. One perfect example for the practical implementation of our collective know-how and the effects which can be achieved is our production hall at the Detmold site. We can use specific examples to show interested customers how well modern Energy Management works in practice.

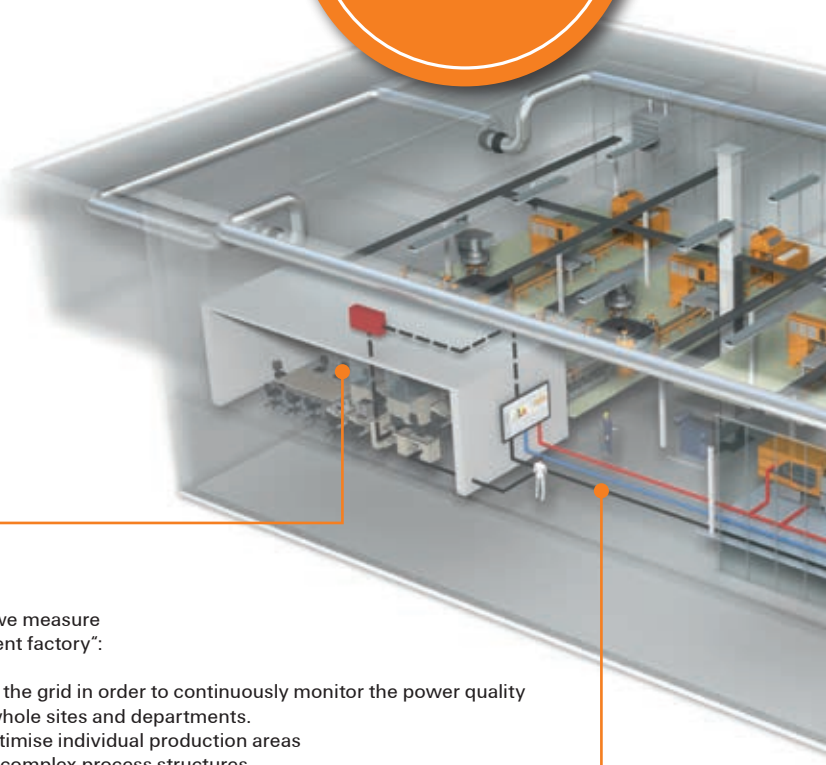

Anchoring Energy Management

All employees are given comprehensive training to increase awareness of conserving energy as a resource. Projects to optimise procurement, increase production efficiency, for new buildings and renovation and handling Energy Management tools are carried out in order to reduce energy consumption even further in future.

Transparency at every level

Depending on the degree of detail required, we measure Energy flows at all five levels in our „transparent factory“:

- Measurement at the point of interface with the grid in order to continuously monitor the power quality
- Measurement at factory level to optimise whole sites and departments.
- Measurement at production line level to optimise individual production areas
- Measurement at machine level to optimise complex process structures
- Measurement at machine module level to optimise individual machine and plant elements

Production area



Employees in production



Annual CO₂ saving

approx. 1.665 t CO₂

Needs-based lighting control

Reduction of basic lighting helps reduce the basic load. Where more light is required, lighting positioned as required provides optimum adapted lighting. The use of efficient control and lighting systems minimises the energy required further still.

Systematic minimisation of energy losses

Load-optimised main consumers guarantee optimum energy use with reduced energy peaks. Systems in standby mode are switched off. This saves energy and helps reduce the basic and peak loads. Transformers are installed at the performance hotspots near the main consumers and fitted with efficient technology to avoid conversion losses. Distribution routes in the low voltage sector which are as short as possible also minimise conductor losses.

Visit our „transparent factory“ with its multi award-winning energy efficiency measures.

Arrange an appointment with your sales engineer or send an e-mail to: energy@weidmueller.com



Efficient use of compressed air

Cascaded compressors are intelligently controlled to ensure the network pressure built up is only what is required. Cables are carefully routed, sealed and constantly checked to minimise cable losses. Employees are made aware of the most efficient use of compressed air to reduce the consumption of compressed air further still.

Efficient heating and cooling

The excess heat generated by processes is transferred to the heating system. The heat extraction reduces the burden on the machine cooling system. A free-cooler uses the ambient air for cooling with minimum use of electrical power and even takes over all cooling work in winter. The core processor heat created when generating compressed air is also used and fed back into the heating system.

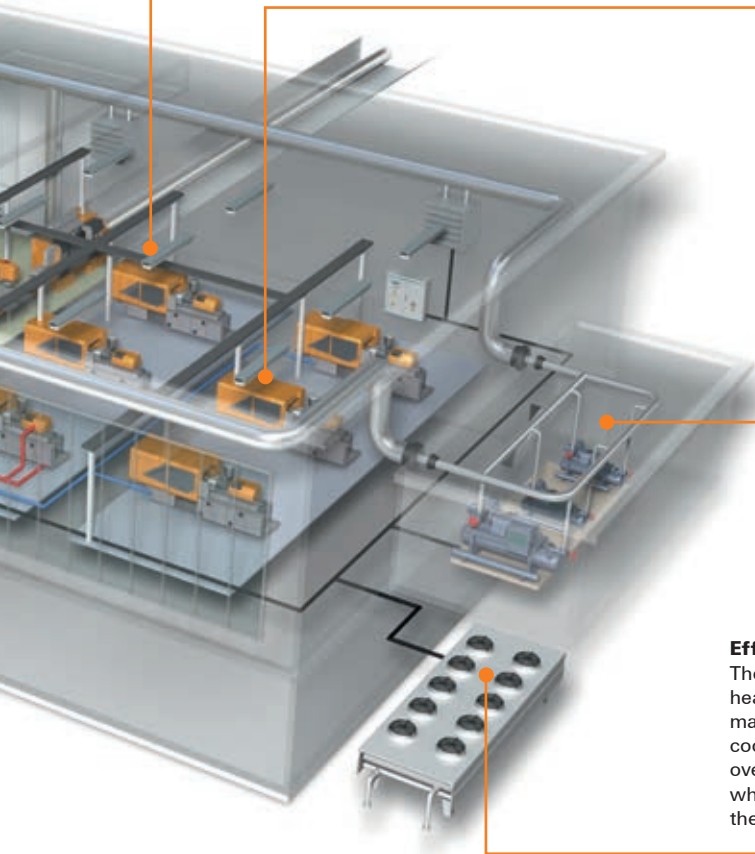

Example for successful Energy Management

Integrated efficiency increase through detailed optimisation

The use of our Energy Management solutions promotes careful handling of resources and ensures not only economical but also environmental benefits to ensure the investment pays in all cases. And sometimes simple measures can be taken to achieve impressive savings, with the expense often paid off quickly than. One example from our own production show just how high the potential energy savings are in detail.

Example: optimisation of hardening ovens

Hardening ovens require a lot of energy and often work with higher temperatures than are actually required for individual working processes. The aim was to reduce peak loads, but the network operator’s load curve did not allow conclusions about the systems or departments.

Approach

First, the main consumers in our company were identified based on our Energy Management system. The hardening oven was identified as the most significant consumer. The efficiency of the hardening oven had already been optimised in the past by an external company. This involved reprogramming the controller.

But the repeat measurement and analysis provided data to prove that no improvement had actually been made. The controller for the hardening oven was then adapted again, which incurred minimal costs.

The load peaks on the hardening oven could then be reduced from around 200 kW to under 100 kW.

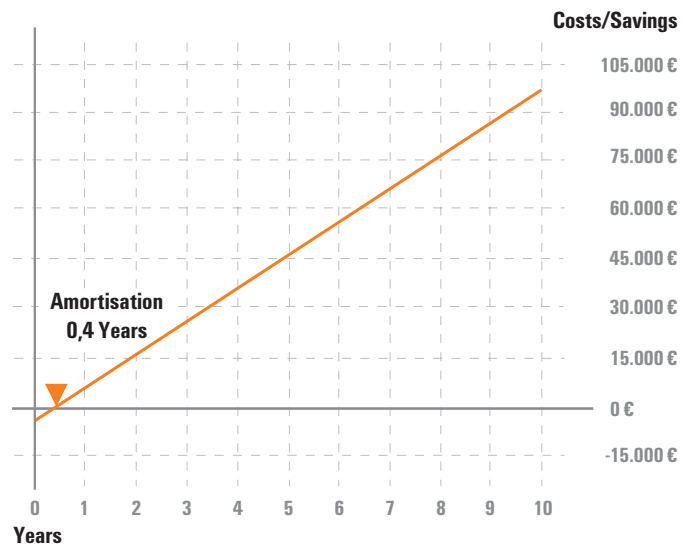

Measures	Costs	Savings
Weidmüller energy measurement devices and installation of hardware in the system	2.720 €	
“u-create ResMa” measurement point strategy and software*	1.050 €	
Processs optimation (material and wage costs for adaption to the sytem)	230 €	
Annual savings		9.910 €
Government funding		**
Total	4.000 €	9.910 €

Amortisation of measures in 0.4 Years

* Proportional calculation based on measurements used

** Not considered separately in this example

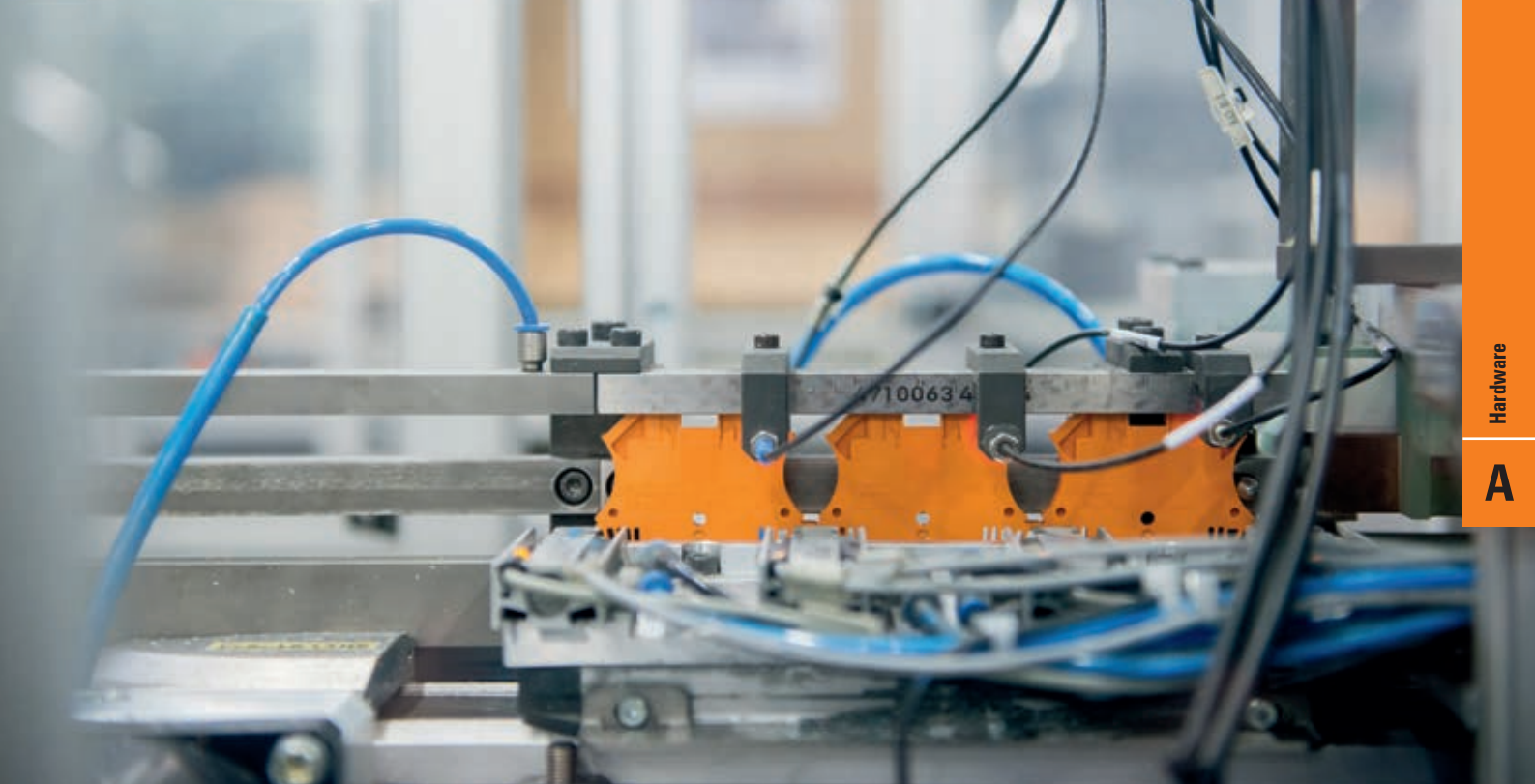

Example: optimisation of compressed air in assembly machines

In order to optimise the energy efficiency of assembly machines for the assembly of modular terminal blocks, the energy demand and savings potential was to be identified on four assembly machines based on data from compressed air and electricity meters.

To do this, the assembly process was broken down into four process sections (sorting and feed-in, installation, high-voltage test, packaging). The energy flows were then distributed across different process stages. Compressed air and current loads were displayed, and the current and compressed air demand were distributed across the individual machine components on a percentage basis. Based on the indices determined, a monitoring process was introduced to enable continuous improvement. On this basis, potential savings could be clearly identified and specific process optimisation steps planned.

Approach

First, four assembly machines were identified as relevant compressed air consumers. They represented around 50 percent of the total factory consumption. In the detailed consideration, the sorting and feeding of the machines as causative agents could be determined for the high compressed air consumption within the assembly process. Processes were also optimised in terms of sorting and in-feed. In the optimised area, compressed air consumption was reduced by 75 percent - with a manifold increase in process stability at the same time. Purely in terms of energy, the implementation of the measures paid off after about 17 months.

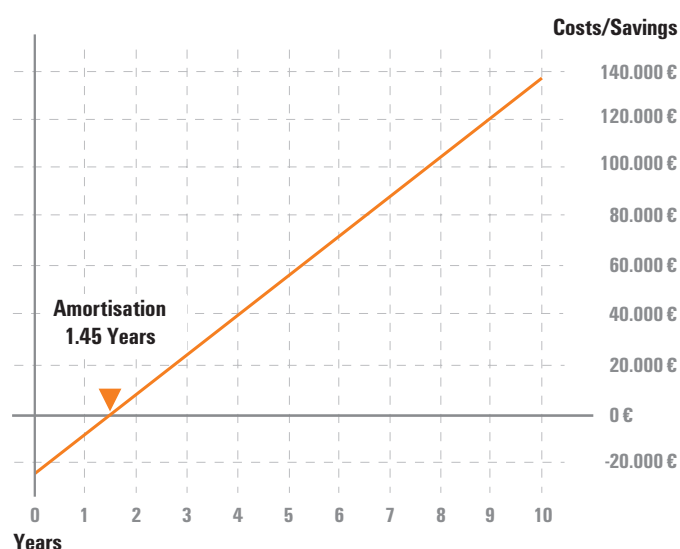

Measures	Costs	Savings
Weidmüller energy measurement devices and installation of hardware in the system	9.700 €	
"u-create ResMa" measurement point strategy and software*	2.550 €	
Processs optimisation (material and wage costs for adaption to the sytem)	10.840 €	
Annual savings		15.900 €
Government funding		**
Total	23.090 €	15.900 €

Amortisation of measures in 1.45 Years

* Proportional calculation based on measurements used

** Not considered separately in this example

Unique energy monitoring and management solutions

Implemented with the „Total Energy Monitoring“ range of products

Weidmüller’s „Total Energy Monitoring“ range is a system toolbox comprising components for all levels to measure and monitor the power supply grid, all the way down to the machine level.

The example application below shows potential configurations of hardware and software. These can be tailored to the customer’s requirements, as well as to comply with ISO 50001, EN 50160 or IEC 61000. From the sensor level to the server or cloud level, we offer a comprehensive package of sensors, measuring instruments, gateways and network technologies. Our portfolio is rounded off by our software suite as well as numerous services.



Components for accurate energy measurement

The Total Energy Monitoring portfolio offers products that meet your needs



Energy meters

The energy measuring devices in the Energy Meters series form the core of the measuring unit. They record and process all the relevant energy data.

Energy analysers

With just one device, you can measure all the quality parameters of the electrical power supply network, create quality analyses and gain a clear visual overview.

Energy loggers

Simplify and accelerate the collection and transmission of consumption and process data for analysis.

u-remote energy measurement module

Measure and calculate reactive, apparent and active power, energy consumption, phase angles and many other electrical parameters.

Reliable monitoring of grid quality

Certified as class A in accordance with IEC 61000-4-30

There is a direct correlation between the quality of the power supply and the lasting security of supply with no noticeable interruptions. Disruptions and damage are often caused by overvoltage and transients. In addition to a reliable supply, high-quality voltage (* point 2. in the figure) is crucial to the reliable operation of equipment with all of its electronic consumers, such as industrial control units or EDP facilities. The grid operator must keep the voltage and frequency as constant as possible, and is liable irrespective of culpability in the event of disruptions (* point 3. in the figure). Precise analysis and documentation using certified procedures are required in order to achieve the greatest possible transparency regarding energy consumption and voltage quality.

Looking for causes

Voltage quality is becoming relevant for an increasing number of providers and consumers – including in the field of renewable energies. More and more photovoltaic and wind power installations have been connected to the medium-voltage grid over the last decade (* point 1. in the figure). The grid operators are responsible for the operation of medium-voltage grids. They therefore have a significant interest in monitoring the quality of electricity at the point of connection with equipment.

Reliable monitoring and error detection

Weidmüller's product portfolio includes the Energy Analyser 750 power quality analyser for comprehensive monitoring. The capabilities it offers allow comprehensive error detection, because in addition to continuously recording consumption it also monitors residual currents. Overvoltage, asymmetries, transients, flicker and other disruption parameters are recorded and analysed. The Energy Analyser 750 complies with all common standards such as EN 50160, IEEE 519 and IEC 61000-2-4, and can be integrated into most communications architectures at low cost thanks to a variety of interfaces.

Generating relevant results

For monitoring it is advisable to use class-A energy analysis devices, which are connected alongside the charging meters. Only analysers that have been certified as class A ensure that the results are reliable, repeatable and comparable. Because regardless of whether you want to hold a "guilty party" to account for damages incurred or identify and remedy sources of disruption as a precaution, this always requires reliable and documented measurements that even stand up in court if necessary.

Detailed insights into equipment

The recording of power quality analysers, which Weidmüller has been selling for years, can also be helpful in this regard. Their extensive analyses and documentation provide a detailed insight into a system. In addition to voltage, frequency and curve shape they also record all forms of disruption. These could be flicker effects or brief voltage drops, which are typical for automated reclosure following electric arc short-circuits. Harmonics from non-linear consumers can also significantly impact the function of other devices. Unlike the basic oscillation in the three-phase system, all of the harmonics that are divisible by three in the neutral conductor reinforce each other instead of cancelling each other out. This can cause the current load on the neutral conductor to rise beyond permissible levels. Harmonics are typically mainly generated by frequency converters as well as surge voltages from switching operations.

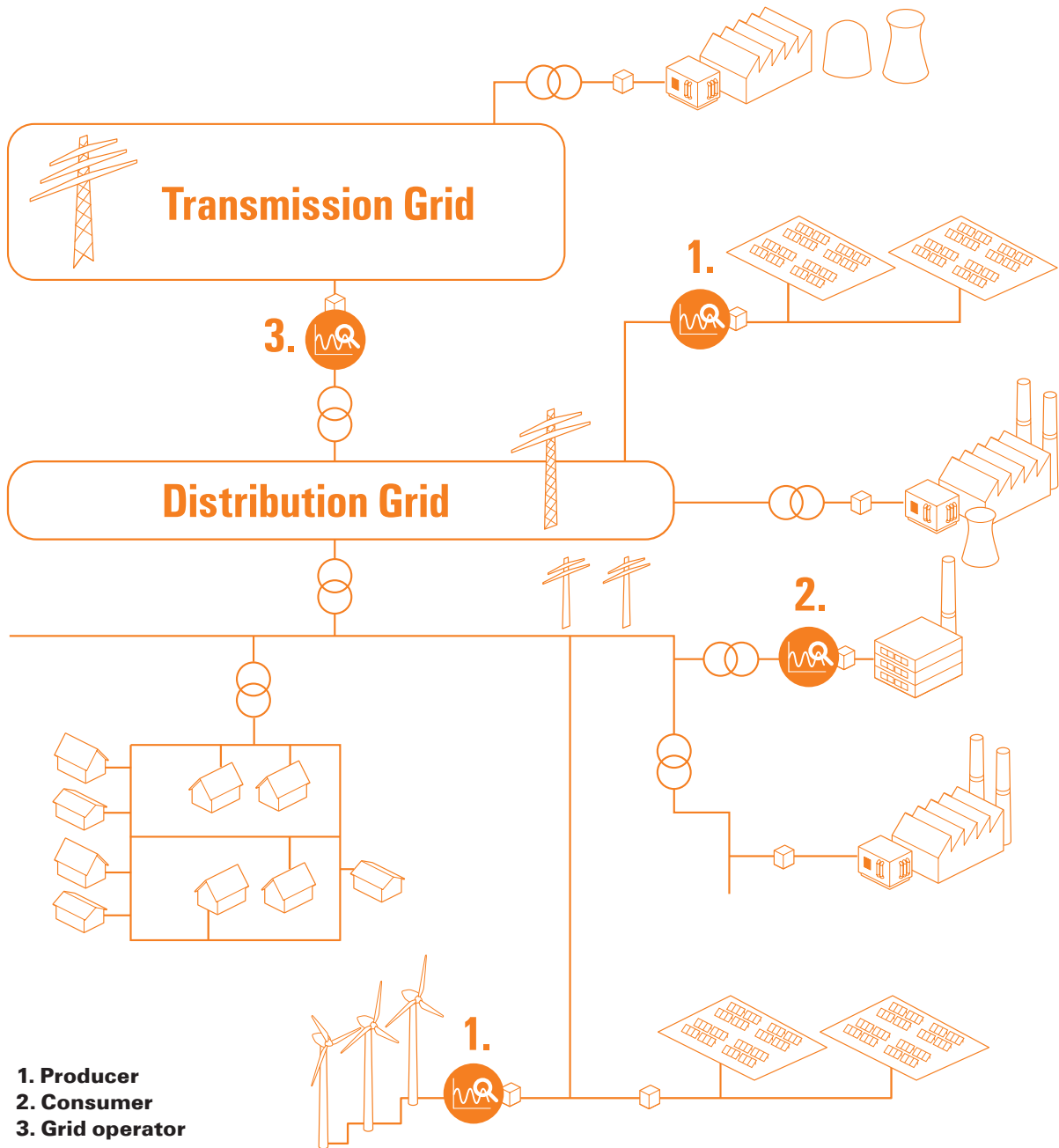

Reliable residual current measurement

Use of RCM (Residual Current Monitoring) measuring instruments

Residual currents caused by the failure of insulation can constitute a significant risk to safety in electrical systems. Using an appropriate protective concept it is possible to detect residual currents, eliminate insulation faults in good time and therefore ensure the availability of the system.

RCM stands for **Residual Current Monitoring** and means the monitoring of residual currents in electrical systems. This current is calculated as the sum of the currents of all conductors, apart from the protective earth (PE), which feed into the system. Residual currents are typically the result of insulation faults, leakage currents or EMC filter leakage currents for example.

Whilst GFI devices (ground fault interrupter) switch off the power supply in the event of a certain residual current being exceeded, RCM measuring devices indicate the actual value, record the long-term development and report the exceeding of a critical value. This message can also be used in order to switch off the power supply via external switching devices (contactors, relays). Through the use of residual current measuring devices it is possible to detect and report residual currents in a timely manner. It is possible to initiate counter measures in good time, so that it is not necessary to switch the system off. This facilitates the implementation of measures in the event of slowly deteriorating insulation values or steadily rising residual currents – caused for example by ageing insulation – before the system is switched off.

Further errors that are detectable by a RCM measurement:

- Insulation faults of lines and electrical operating resources
- Residual currents from electrical loads
- Defective PP power capacitors for the PFC
- Defective components in switched mode power supplies, e.g. in computers
- Correctness of TNS systems (Terra Neutral Separate)
- Disclosure of impermissible PEN connections
- Avoidance of neutral conductor reverse currents to grounded equipment

Residual current monitoring in conjunction with energy measurement in combined energy / RCM measuring devices in electrical systems constitutes a measure for fire protection and maintenance prevention. Down times and the associated costs are thereby reduced. Timely and preventative maintenance – facilitated through the information additionally gained from an RCM measuring device – also significantly enhances the efficiency and availability of a system.

Constant RCM monitoring is of particular significance in preventing unwanted surprises in ongoing operation, and provides consistent information regarding the actual status of the electrical system.

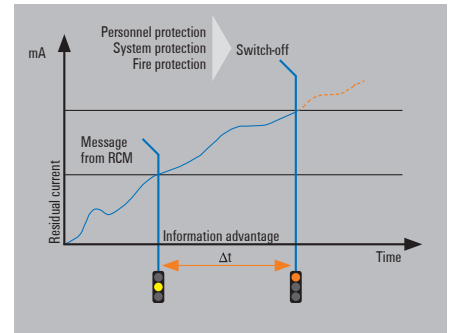
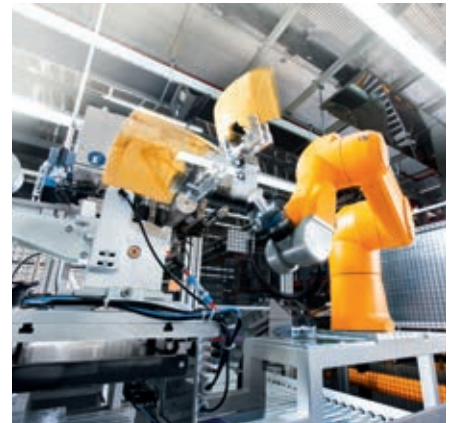
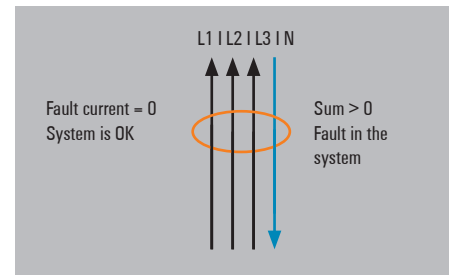

Fig.: Report prior to switching off - an aim of residual current monitoring



Fundamental measuring process with RCM

The functionality of RCM measuring devices is based on the differential current principle. This requires that all phases be guided through a residual current transformer at the measuring point (outlet to be protected), with the exception of the protective earth. If there is no failure in the system then the sum of all currents will be nil. If, however, residual current is flowing away to ground then the difference will result in the current at the residual current transformer being evaluated by the electronics in the RCM measuring device.



Typical applications

RCM measuring instruments are mainly used in systems where a high level of availability is required, such as:

- Data processing centres, production facilities, hospitals, telecommunications
- TN-S systems with strict EMC requirements
- Equipment at risk of fire
- Equipment in cleanroom conditions
- Research facilities, laboratory technology areas

Weidmüller combines Energy Management, grid quality and residual current monitoring in a single system, providing you with a holistic solution from medium voltage down to the individual circuit.

The following measuring instruments support RCM measurement:

- Energy Meter 700-PN
- Energy Meter 750
- Energy Analyser 550
- Energy Analyser 750

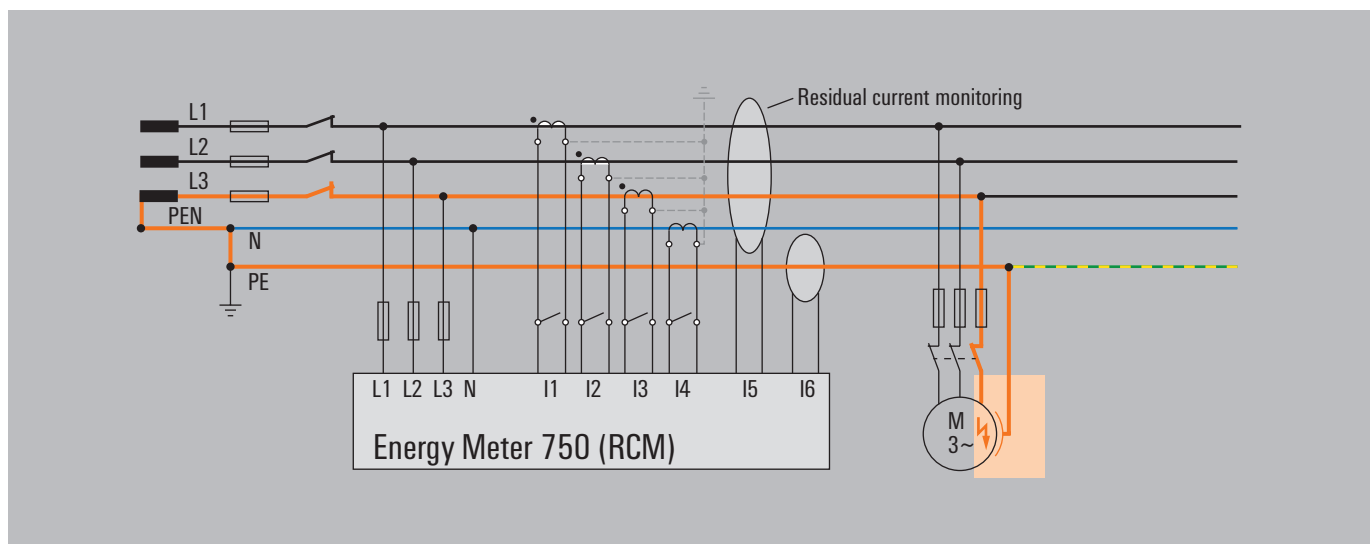

Overview of energy meters



Type	EM D370-CBM	EM D650	EM 330	EM 350	EM 520		EM 525		EM 610	
	2540830000	2425490000	2425410000	2425420000	24	230	24	230	24	230
Ord. No	2540830000	2425490000	2425410000	2425420000	2500860000	2500880000	2540880000	2540890000	2540920000	2540850000
Technical Characteristics										
Measuring range, Voltage L-N, AC (without transducer)	277 V	277 V	255 V	275 V	277 V		277 V		277 V	
Measuring range, Voltage L-L, AC (without transducer)	480 V	480 V	442 V	476 V	480 V		480 V		480 V	
Overvoltage category	300 V CAT III	300 V CAT III	300 V CAT III	300 V CAT III	300 V CAT III		300 V CAT III		300 V CAT III	
Power supply voltage	-	95 - 240 V AC; 135 - 340 V DC	196 - 255 V AC	196 - 275 V AC	24 - 90 V AC; 24 - 90 V DC	90 - 277 V AC; 90 - 250 V DC	24 - 90 V AC; 24 - 90 V DC	90 - 277 V AC; 90 - 250 V DC	24 - 90 V AC; 24 - 90 V DC	90 - 277 V AC; 90 - 250 V DC
Three wire	-	•	-	-	•	-	•	-	•	-
Four wire	•	•	•	•	•	•	•	•	•	•
Quadrants	4	4	4	4	4		4		4	
Sampling frequency 50/60 Hz	5.4 kHz	20 kHz	2.5 / 3 kHz	2.5 / 3 kHz	21.33 / 25.6 kHz		21.33 / 25.6 kHz		21.33 / 25.6 kHz	
Measurement points per second	5.400	20.000	3.000	3.000	21.330 / 25.600		21.330 / 25.600		21.330 / 25.600	
Uninterrupted measurement	•	•	-	-	•	•	•	•	•	•
Measurement results per second	5	5	1	1	5		5		5	
Effective value from periods (50 / 60 Hz)	10 / 12	10 / 12	1 / 1	1 / 1	10 / 12		10 / 12		10 / 12	
Residual current measurement	-	-	-	-	-		-		-	
Harmonics per order / Voltage	1. - 25.	1. - 40.	-	-	1. - 40.		1. - 40.		1. - 40.	
Harmonics per order / Current	1. - 25.	1. - 40.	-	-	1. - 40.		1. - 40.		1. - 40.	
Distortion factor THD-U in %	•	•	-	-	•		•		•	
Distortion factor THD-I in %	•	•	-	-	•		•		•	
Unbalance	-	•	-	-	-		-		-	
Positive / Negative / zero sequence component	•	•	-	-	•		•		•	
Present flicker strength	-	-	-	-	-		-		-	
Short- / long-term flicker	-	-	-	-	-		-		-	
Short-term interruptions, events	-	-	-	-	-		-		-	
Accuracy voltage	0.20%	0.20%	1%	1%	0.20%		0.20%		0.20%	
Accuracy current	0.20%	0.25%	1%	1%	0.20%		0.20%		0.20%	
Effective power class	0.5S (.../5A)	0.5S (.../5A)	2	2	0.5S (.../5 A)		0.5S (.../5 A)		0.5S (.../5 A)	
Operating hours counter	•	•	•	•	•		•		•	
Weekly timer	-	-	-	-	-		-		-	
Number of digital inputs	-	2	-	-	-		-		4	
Number of digital outputs	-	2	-	2	2		-		6	
Number of pulse outputs	-	2	-	2	2		-		6	
Current measurement channel	3	4	3	3	3		3		4	
Temperature input	-	1	-	-	-		-		-	
Integrated logic	-	Comperator	-	-	Comperator		Comperator		Comperator	
Minimum and maximum values for memory	•	•	•	•	•		•		•	
Memory size for onboard recording	4 MB Flash	4 MB Flash	-	-	-		-		256 MB	
Number of memory values	160 k	156 k	-	-	-		-		10.000 k	
Clock	•	•	-	-	•		•		•	
Bi-metallic function	•	•	•	•	•		•		•	
Error / event recorder function	-	-	-	-	-		-		-	
Peak demand management (optional)	-	-	-	-	-		-		-	
Config Software	ecoExplorer go®	ecoExplorer go®	-	-	ecoExplorer go®		ecoExplorer go®		ecoExplorer go®	
update interval register	200 ms	200 ms	-	-	200 ms		200 ms		200 ms	
smallest time interval of recording Memory	1 min	1 min	-	-	-		-		1 min	
Interfaces										
RS232	-	•	-	-	-		-		-	
RS485	•	•	-	-	•		-		•	
USB	-	-	-	-	-		-		•	
Profibus DP	-	-	-	-	-		-		-	
Ethernet	-	-	-	-	-		•		-	
Webserver / E-Mail	-	-	-	-	-		-		-	
Protocols										
Modbus RTU	•	•	-	-	•		-		•	
Modbus-Gateway	-	-	-	-	-		-		-	
Profibus DP VO	-	-	-	-	-		-		-	
Modbus TCP/IP, Modbus RTU over Ethernet, SNMP	-	-	-	-	-		•		-	
BACnet (optional)	-	-	-	-	-		-		-	
Profinet	-	-	-	-	-		-		-	



EM 610-PB		EM 750		EM 700-PN		EA D550		EA 550		EA 750		Energy Logger D550
24	230	24	230	24	230	24	230	24	230	24	230	
2540860000	2540870000	2540900000	2540910000	2500870000	2500890000	2425510000	2489780000	2602580000	2425500000	2534160000	2534130000	2425520000
277 V		277 V		277 V		277 V		417 V		347 V		-
480 V		480 V		480 V		480 V		720 V (3-conductor 600 V)		600 V		-
300 V CAT III		300 V CAT III		300 V CAT III		300 V CAT III		600 V CAT III		600 V CAT III		300 V CAT III
24 - 90 V AC; 24 - 90 V DC	90 - 277 V AC; 90 - 250 V DC	24 - 90 V AC; 24 - 90 V DC	90 - 277 V AC; 90 - 250 V DC	24 - 90 V AC; 24 - 90 V DC	90 - 277 V AC; 90 - 250 V DC	20 - 50 V AC; 20 - 70 V DC	95 - 240 V AC; 135 - 340 V DC	48 - 110 V AC; 24 - 150 V DC	95 - 240 V AC; 80 - 300 V DC	48 - 110 V AC; 24 - 150 V DC	95 - 240 V AC; 80 - 300 V DC	20 - 250 V AC; 20 - 300 V DC
•	•	•	•	•	•	•	•	•	•	•	•	-
•	•	•	•	•	•	•	•	•	•	•	•	-
4	4	4	4	4	4	4	4	4	4	4	4	-
21.33 / 25.6 kHz 21.330 / 25.600	21.33 / 25.6 kHz 21.330 / 25.600	21.33 / 25.6 kHz 21.330 / 25.600	21.33 / 25.6 kHz 21.330 / 25.600	21.33 / 25.6 kHz 21.330 / 25.600	21.33 / 25.6 kHz 21.330 / 25.600	20 kHz 20.000	20 kHz 20.000	20 kHz 20.000	20 kHz 20.000	25.6 kHz 25.600	25.6 kHz 25.600	-
•	•	•	•	•	•	•	•	•	•	•	•	-
5	5	5	5	5	5	5	5	5	5	5	5	-
10 / 12	10 / 12	10 / 12	10 / 12	10 / 12	10 / 12	10 / 12	10 / 12	10 / 12	10 / 12	10 / 12	10 / 12	-
-	•	-	•	-	•	-	•	-	•	-	•	-
1 - 40.	1 - 40.	1 - 40.	1 - 40.	1 - 40.	1 - 40.	1 - 40.	1 - 40.	1 - 63.	1 - 63.	1 - 63.	1 - 63.	-
1 - 40.	1 - 40.	1 - 40.	1 - 40.	1 - 40.	1 - 40.	1 - 40.	1 - 40.	1 - 63.	1 - 63.	1 - 63.	1 - 63.	-
•	•	•	•	•	•	•	•	•	•	•	•	-
•	•	•	•	•	•	•	•	•	•	•	•	-
-	-	-	-	-	-	-	-	-	-	-	-	-
-	-	-	-	-	-	-	-	-	-	-	-	-
-	-	-	-	-	-	-	-	-	-	-	-	-
0.20%	0.20%	0.20%	0.20%	0.20%	0.20%	0.20%	0.25%	0.10%	0.10%	0.10%	0.10%	-
0.20%	0.20%	0.20%	0.20%	0.20%	0.20%	0.25%	0.25%	0.10%	0.10%	0.10%	0.10%	-
0.5S (.../5 A)	0.5S (.../5 A)	0.5S (.../5 A)	0.5S (.../5 A)	0.5S (.../5 A) / 1 (.../1A)	0.5S (.../5 A) / 1 (.../1A)	0.5S (.../5 A) / 1 (.../1A)	0.5S (.../5 A) / 1 (.../1A)	0.2S (.../5 A)	0.2S (.../5 A)	0.2S (.../5 A)	0.2S (.../5 A)	-
•	•	•	•	•	•	•	•	•	•	•	•	•
-	-	-	-	-	-	Jasic	Jasic	•	•	•	•	-
4	3	3	3	3	3	2	2	2	2	2	2	15
6	5	5	5	5	5	2	2	2	2	2	2	3
6	5	5	5	5	5	2	2	2	2	2	2	3
4	4+2	4+2	4+2	4+2	4+2	4	4	4+2	4+2	4+2	4+2	-
-	2	2	2	2	2	1	1	1	1	1	1	1
Comperator	Comperator	Comperator	Comperator	Comperator	Comperator	Jasic®	Jasic®	Jasic®	Jasic®	Jasic®	Jasic®	-
•	•	•	•	•	•	•	•	•	•	•	•	•
256 MB	256 MB	-	-	-	-	128 MB	128 MB	256 MB	256 MB	256 MB	256 MB	32 MB
10.000 k	10.000 k	-	-	-	-	5.000 k	5.000 k	10.000 k	10.000 k	10.000 k	10.000 k	-
•	•	•	•	•	•	•	•	•	•	•	•	•
•	•	•	•	•	•	•	•	•	•	•	•	•
-	-	-	-	-	-	•	•	•	•	•	•	-
-	-	-	-	-	-	•	•	•	•	•	•	-
ecoExplorer go®	ecoExplorer go®	ecoExplorer go®	ecoExplorer go®	ecoExplorer go®	ecoExplorer go®	ecoExplorer go®	ecoExplorer go®	ecoExplorer go®	ecoExplorer go®	ecoExplorer go®	ecoExplorer go®	ecoExplorer go®
200 ms	200 ms	200 ms	200 ms	200 ms	200 ms	200 ms	200 ms	200 ms	200 ms	200 ms	200 ms	-
1 min	1 min	-	-	-	-	1 min	1 min	1 s	1 s	1 s	1 s	-
-	-	-	-	-	-	•	•	-	-	-	-	-
•	•	•	•	•	•	•	•	•	•	•	•	•
•	•	•	•	•	•	•	•	•	•	•	•	•
•	•	•	•	•	•	•	•	•	•	•	•	•
-	-	-	-	-	-	•	•	•	•	•	•	-
-	• / •	• / -	• / -	• / -	• / -	• / •	• / •	• / •	• / •	• / •	• / •	-
•	•	•	•	•	•	•	•	•	•	•	•	•
-	•	-	-	-	-	•	•	•	•	•	•	•
•	•	•	•	•	•	•	•	•	•	•	•	•
-	•	-	-	-	-	•	•	•	•	•	•	-
-	-	-	-	-	-	•	•	•	•	•	•	-
-	-	-	-	-	-	•	•	•	•	•	•	-

Hardware
A

Measure energy consumption of production systems in detail

Weidmüller energy meters make energy efficiency transparent



Key data at a glance

For devices with integrated display, important measurement data such as voltage, current, power and energy can be easily read off.

Excellent scalability

The comprehensive range of energy measuring devices means you can break down the energy networks for your production sites as accurately as you wish and measure them in detail.

Energy networks for industrial systems are complex. Our energy meters make it possible to break them down into manageable areas in order to easily analyse consumption and other energy parameters.

Many companies want to protect energy sources, use energy more efficiently and improve the availability of energy networks. This not only demonstrates responsibility, but is also recommended for economical reasons. Weidmüller energy meters can do much more than measure consumption of electrical energy. They can, for example, also determine basic parameters on energy quality or analyse the current from all conductors individually or on a differential basis – such as our Energy Meter 750, for example.

This gives you a quick overview of what is going on with the electrical energy in your production facility. That applies both to efficient use and to quality, stability and availability.

But not all measuring devices are suitable for all applications. You can select the perfect measuring device for each of your system components from our comprehensive, modular portfolio of devices.

Highest level of compliance with the PROFINET standard

Weidmüller Energy Meter 700-PN

Depending on the field in which it is being used, a marketable Industrial Ethernet must support functional security as well as the entire range of drive technology through to synchronous motion control with cycle times of less than a millisecond. This is best achieved by cleverly dividing up the protocols using the OSI layer model, as well as using a standard such as PROFINET that is widespread in all mechanical and plant engineering applications.

Costs are already saved at the installation, engineering and commissioning stages thanks to the open and modular PROFINET concept (The operator benefits from the simple expansion and high availability through autonomous subsystems).

Energy Meter 700-PN – the PROFINET specialist

Our Energy Meter 700-PN has two PROFINET-compliant Ethernet interfaces as well as an integrated switch for building up line topologies. The measurements recorded can be visualised and evaluated in real time using our u-create ResMa software. Another highlight is the integrated residual current measuring (RCM).



PROFINET-certified and suitable for the use of PROFlenergy

A PROFINET certificate certifies that our Energy Meter 700-PN complies with IEC 61158 within a PROFINET network, thus ensuring a high standard of quality. It is also suitable for the use of PROFlenergy, a profile for Energy Management in production machinery based on PROFINET. This allows energy consumption within the system to be managed using open and standardised commands. External, hard-wired systems are no longer required.

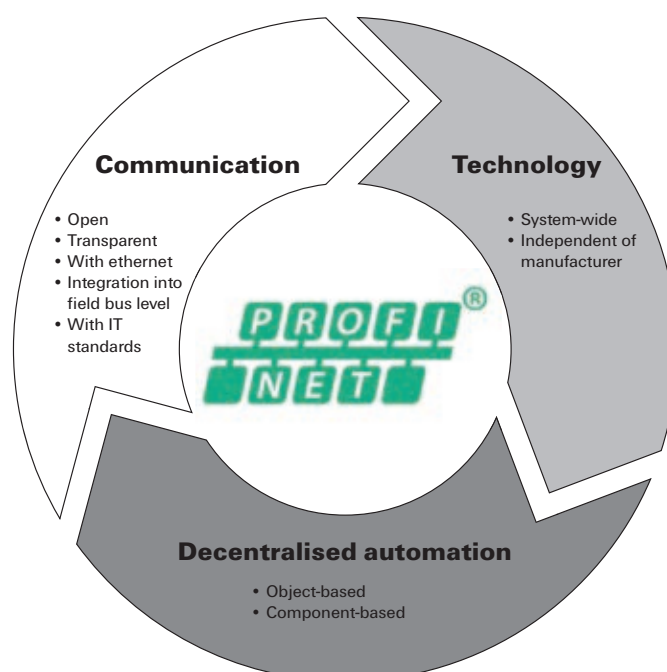

Energy meters for DIN rail mounting

Energy Meter 370-CBM

Energy Meter D650



Technical data

Measurement range, voltage L-N, AC	277 V	277 V
Measurement range, voltage L-L, AC	480 V	480 V
Surge voltage category	300 V CAT III	300 V CAT III
Supply voltage		95 - 240 V AC, 135 - 340 V DC
Three-wire system	No	Yes
Four-wire system	Yes	Yes
Quadrants	4	4
Sampling frequency 50/60 Hz	5.4 kHz	20 kHz
Continuous measurements	Yes	Yes
Effective value from the period (50/60 Hz)	10 / 12	10 / 12
Measurement result per second	5	5
Residual current measuring	No	No
Harmonics, per order / voltage	1-25, odd	1-40
Harmonics, per order / current	1-25, odd	1-40
Unbalanced	No	Yes
Positive, negative and zero system	Yes	Yes
Measuring accuracy for voltage	0.2 %	0.2 %
Measuring accuracy for current	0.2 %	0.25 %
Measurement accuracy for active energy (kWh, .../5 A)	Class 0.5S	Class 0.5S
Number of digital inputs		2
Number of digital outputs		2
Number of pulse outputs		2
Current-measuring channels	3	4
Temperature input	No	Yes
Memory; minimum and maximum values	Yes	Yes
Memory size	4 MB	4 MB
Interface	RS485: 9.6 - 921.6 kbps	RS232: 9.6 - 115.2 kbps, RS485: 9.6 - 921.6 kbps
Protocol	Modbus RTU	Modbus RTU
Note		

Ordering data

Type	Qty.	Order No.	Type	Qty.	Order No.
ENERGY METER D370-CBM	1	2540830000	ENERGY METER D650	1	2425490000
Note					

Accessories

Type	Qty.	Order No.	Type	Qty.	Order No.

Note					
-------------	--	--	--	--	--

Energy meters for front panel mounting

Energy Meter 330

Energy Meter 350



Technical data

Measurement range, voltage L-N, AC
Measurement range, voltage L-L, AC
Surge voltage category
Supply voltage
Three-wire system
Four-wire system
Quadrants
Sampling frequency 50/60 Hz
Continuous measurements
Effective value from the period (50/60 Hz)
Measurement result per second
Residual current measuring
Harmonics, per order / voltage
Harmonics, per order / current
Unbalanced
Positive, negative and zero system
Measuring accuracy for voltage
Measuring accuracy for current
Measurement accuracy for active energy (kWh, .../5 A)
Number of digital inputs
Number of digital outputs
Number of pulse outputs
Current-measuring channels
Temperature input
Memory; minimum and maximum values
Memory size
Interface
Protocol
Note

255 V
442 V
300 V CAT III
196...255 V AC
No
Yes
4
3 kHz
No
1 / 1
1
No
No
No
1 %
1 %
Class 2
3
No
Yes
Note

275 V
476 V
300 V CAT III
196...275 V AC
No
Yes
4
3 kHz
No
1 / 1
1
No
No
No
1 %
1 %
Class 2
2
2
3
No
Yes
Note

Ordering data

Note

Type	Qty.	Order No.
ENERGY METER 330	1	2425410000

Type	Qty.	Order No.
ENERGY METER 350	1	2425420000

Accessories

DIN rail adapters
Seal
Fixing clamps

	Qty.	Order No.
ENERGY METER BRACKET S1	1	2433080000
ENERGY METER SEAL L96-1	1	2495640000
ENERGY METER FIXING SET	1	2433030000

	Qty.	Order No.
ENERGY METER BRACKET S1	1	2433080000
ENERGY METER SEAL L96-1	1	2495640000
ENERGY METER FIXING SET	1	2433030000

Note

--

--

Energy meters for front panel mounting

Energy Meter 520-24

Energy Meter 520-230



Technical data

Measurement range, voltage L-N, AC	277 V
Measurement range, voltage L-L, AC	480 V
Surge voltage category	300 V CAT III
Supply voltage	24 - 90 V AC (50/60 Hz), 24 - 90 V DC
Three-wire system	Yes
Four-wire system	Yes
Quadrants	4
Sampling frequency 50/60 Hz	25.6 kHz
Continuous measurements	Yes
Effective value from the period (50/60 Hz)	10 / 12
Measurement result per second	5
Residual current measuring	No
Harmonics, per order / voltage	1-40.
Harmonics, per order / current	1-40.
Unbalanced	No
Positive, negative and zero system	Yes
Measuring accuracy for voltage	0.2 %
Measuring accuracy for current	0.2 %
Measurement accuracy for active energy (kWh, .../5 A)	Class 0.5S
Number of digital inputs	
Number of digital outputs	2
Number of pulse outputs	2
Current-measuring channels	3
Temperature input	No
Memory; minimum and maximum values	Yes
Memory size	
Interface	RS485: 9.6 - 921.6 kbps
Protocol	Modbus RTU
Note	

Measurement range, voltage L-N, AC	277 V
Measurement range, voltage L-L, AC	480 V
Surge voltage category	300 V CAT III
Supply voltage	24 - 90 V AC (50/60 Hz), 24 - 90 V DC
Three-wire system	Yes
Four-wire system	Yes
Quadrants	4
Sampling frequency 50/60 Hz	25.6 kHz
Continuous measurements	Yes
Effective value from the period (50/60 Hz)	10 / 12
Measurement result per second	5
Residual current measuring	No
Harmonics, per order / voltage	1-40.
Harmonics, per order / current	1-40.
Unbalanced	No
Positive, negative and zero system	Yes
Measuring accuracy for voltage	0.2 %
Measuring accuracy for current	0.2 %
Measurement accuracy for active energy (kWh, .../5 A)	Class 0.5S
Number of digital inputs	
Number of digital outputs	2
Number of pulse outputs	2
Current-measuring channels	3
Temperature input	No
Memory; minimum and maximum values	Yes
Memory size	
Interface	RS485: 9.6 - 921.6 kbps
Protocol	Modbus RTU
Note	

Measurement range, voltage L-N, AC	277 V
Measurement range, voltage L-L, AC	480 V
Surge voltage category	300 V CAT III
Supply voltage	90 - 277 V AC (50/60 Hz), 90 - 250 V DC
Three-wire system	Yes
Four-wire system	Yes
Quadrants	4
Sampling frequency 50/60 Hz	25.6 kHz
Continuous measurements	Yes
Effective value from the period (50/60 Hz)	10 / 12
Measurement result per second	5
Residual current measuring	No
Harmonics, per order / voltage	1-40.
Harmonics, per order / current	1-40.
Unbalanced	No
Positive, negative and zero system	Yes
Measuring accuracy for voltage	0.2 %
Measuring accuracy for current	0.2 %
Measurement accuracy for active energy (kWh, .../5 A)	Class 0.5S
Number of digital inputs	
Number of digital outputs	2
Number of pulse outputs	2
Current-measuring channels	3
Temperature input	No
Memory; minimum and maximum values	Yes
Memory size	
Interface	RS485: 9.6 - 921.6 kbps
Protocol	Modbus RTU
Note	

Ordering data

Note

Type	Qty.	Order No.
ENERGY METER 520-24	1	2500860000

Type	Qty.	Order No.
ENERGY METER 520-230	1	2500880000

Accessories

DIN rail adapters
Seal
Fixing clamps

	Qty.	Order No.
ENERGY METER BRACKET S2	1	2433070000
ENERGY METER SEAL L96-2	1	2495610000
ENERGY METER FIXING SET	1	2433030000

	Qty.	Order No.
ENERGY METER BRACKET S2	1	2433070000
ENERGY METER SEAL L96-2	1	2495610000
ENERGY METER FIXING SET	1	2433030000

Note

Note

Note

Energy meters for front panel mounting

Energy Meter 525-24

Energy Meter 525-230



Technical data

Measurement range, voltage L-N, AC
Measurement range, voltage L-L, AC
Surge voltage category
Supply voltage
Three-wire system
Four-wire system
Quadrants
Sampling frequency 50/60 Hz
Continuous measurements
Effective value from the period (50/60 Hz)
Measurement result per second
Residual current measuring
Harmonics, per order / voltage
Harmonics, per order / current
Unbalanced
Positive, negative and zero system
Measuring accuracy for voltage
Measuring accuracy for current
Measurement accuracy for active energy (kWh, .../5 A)
Number of digital inputs
Number of digital outputs
Number of pulse outputs
Current-measuring channels
Temperature input
Memory; minimum and maximum values
Memory size
Interface
Protocol
Note

277 V
480 V
300 V CAT III
24 - 90 V AC (50/60 Hz), 24 - 90 V DC
Yes
Yes
4
25.6 kHz
Yes
10 / 12
5
No
1-40.
1-40.
No
Yes
0.2 %
0.2 %
Class 0.5S
3
No
Yes
Ethernet
Modbus TCP/IP, Modbus RTU over Ethernet, SNMP
Note

277 V
480 V
300 V CAT III
90 - 277 V AC (50/60 Hz), 90 - 250 V DC
Yes
Yes
4
25.6 kHz
Yes
10 / 12
5
No
1-40.
1-40.
No
Yes
0.2 %
0.2 %
Class 0.5S
3
No
Yes
Ethernet
Modbus TCP/IP, Modbus RTU over Ethernet, SNMP
Note

Ordering data

Note

Type	Qty.	Order No.
ENERGY METER 525-24	1	2540880000

Type	Qty.	Order No.
ENERGY METER 525-230	1	2540890000

Accessories

DIN rail adapters
Seal
Fixing clamps

	Qty.	Order No.
ENERGY METER BRACKET L1	1	2433060000
ENERGY METER SEAL L96-2	1	2495610000
ENERGY METER FIXING SET	1	2433030000

	Qty.	Order No.
ENERGY METER BRACKET L1	1	2433060000
ENERGY METER SEAL L96-2	1	2495610000
ENERGY METER FIXING SET	1	2433030000

Note

Note

Note

Energy meters for front panel mounting

Energy Meter 610-24

Energy Meter 610-230



Technical data

Measurement range, voltage L-N, AC	277 V
Measurement range, voltage L-L, AC	480 V
Surge voltage category	300 V CAT III
Supply voltage	24 - 90 V AC (50/60 Hz), 24 - 90 V DC
Three-wire system	Yes
Four-wire system	Yes
Quadrants	4
Sampling frequency 50/60 Hz	25.6 kHz
Continuous measurements	Yes
Effective value from the period (50/60 Hz)	10 / 12
Measurement result per second	5
Residual current measuring	No
Harmonics, per order / voltage	1-40.
Harmonics, per order / current	1-40.
Unbalanced	No
Positive, negative and zero system	Yes
Measuring accuracy for voltage	0.2 %
Measuring accuracy for current	0.2 %
Measurement accuracy for active energy (kWh, .../5 A)	Class 0.5S
Number of digital inputs	4
Number of digital outputs	6
Number of pulse outputs	6
Current-measuring channels	4
Temperature input	No
Memory; minimum and maximum values	Yes
Memory size	256 MB
Interface	RS485: 9.6 - 921.6 kbps, USB
Protocol	Modbus RTU
Note	

Measurement range, voltage L-N, AC	277 V
Measurement range, voltage L-L, AC	480 V
Surge voltage category	300 V CAT III
Supply voltage	24 - 90 V AC (50/60 Hz), 24 - 90 V DC
Three-wire system	Yes
Four-wire system	Yes
Quadrants	4
Sampling frequency 50/60 Hz	25.6 kHz
Continuous measurements	Yes
Effective value from the period (50/60 Hz)	10 / 12
Measurement result per second	5
Residual current measuring	No
Harmonics, per order / voltage	1-40.
Harmonics, per order / current	1-40.
Unbalanced	No
Positive, negative and zero system	Yes
Measuring accuracy for voltage	0.2 %
Measuring accuracy for current	0.2 %
Measurement accuracy for active energy (kWh, .../5 A)	Class 0.5S
Number of digital inputs	4
Number of digital outputs	6
Number of pulse outputs	6
Current-measuring channels	4
Temperature input	No
Memory; minimum and maximum values	Yes
Memory size	256 MB
Interface	RS485: 9.6 - 921.6 kbps, USB
Protocol	Modbus RTU
Note	

Measurement range, voltage L-N, AC	277 V
Measurement range, voltage L-L, AC	480 V
Surge voltage category	300 V CAT III
Supply voltage	90 - 277 V AC (50/60 Hz), 90 - 250 V DC
Three-wire system	Yes
Four-wire system	Yes
Quadrants	4
Sampling frequency 50/60 Hz	25.6 kHz
Continuous measurements	Yes
Effective value from the period (50/60 Hz)	10 / 12
Measurement result per second	5
Residual current measuring	No
Harmonics, per order / voltage	1-40.
Harmonics, per order / current	1-40.
Unbalanced	No
Positive, negative and zero system	Yes
Measuring accuracy for voltage	0.2 %
Measuring accuracy for current	0.2 %
Measurement accuracy for active energy (kWh, .../5 A)	Class 0.5S
Number of digital inputs	4
Number of digital outputs	6
Number of pulse outputs	6
Current-measuring channels	4
Temperature input	No
Memory; minimum and maximum values	Yes
Memory size	256 MB
Interface	RS485: 9.6 - 921.6 kbps, USB
Protocol	Modbus RTU
Note	

Ordering data

Note

Type	Qty.	Order No.
ENERGY METER 610-24	1	2540920000

Type	Qty.	Order No.
ENERGY METER 610-230	1	2540850000

Accessories

DIN rail adapters
Seal
Fixing clamps

	Qty.	Order No.
ENERGY METER BRACKET L1	1	2433060000
ENERGY METER SEAL L96-2	1	2495610000
ENERGY METER FIXING SET	1	2433030000

	Qty.	Order No.
ENERGY METER BRACKET L1	1	2433060000
ENERGY METER SEAL L96-2	1	2495610000
ENERGY METER FIXING SET	1	2433030000

Note

Note

Note

Energy meters for front panel mounting

Energy Meter 610-PB-24

Energy Meter 610-PB-230



Technical data

Measurement range, voltage L-N, AC
Measurement range, voltage L-L, AC
Surge voltage category
Supply voltage
Three-wire system
Four-wire system
Quadrants
Sampling frequency 50/60 Hz
Continuous measurements
Effective value from the period (50/60 Hz)
Measurement result per second
Residual current measuring
Harmonics, per order / voltage
Harmonics, per order / current
Unbalanced
Positive, negative and zero system
Measuring accuracy for voltage
Measuring accuracy for current
Measurement accuracy for active energy (kWh, .../5 A)
Number of digital inputs
Number of digital outputs
Number of pulse outputs
Current-measuring channels
Temperature input
Memory; minimum and maximum values
Memory size
Interface
Protocol
Note

277 V
480 V
300 V CAT III
24 - 90 V AC (50/60 Hz), 24 - 90 V DC
Yes
Yes
4
25.6 kHz
Yes
10 / 12
5
No
1-40.
1-40.
No
Yes
0.2 %
0.2 %
Class 0.5S
4
6
6
4
No
Yes
256 MB
RS485: 9.6 - 921.6 kbps, Profibus DP, USB
Modbus RTU, Profibus DP V0
Note

277 V
480 V
300 V CAT III
90 - 277 V AC (50/60 Hz), 90 - 250 V DC
Yes
Yes
4
25.6 kHz
Yes
10 / 12
5
No
1-40.
1-40.
No
Yes
0.2 %
0.2 %
Class 0.5S
4
6
6
4
No
Yes
256 MB
RS485: 9.6 - 921.6 kbps, Profibus DP, USB
Modbus RTU, Profibus DP V0
Note

Ordering data

Note

Type	Qty.	Order No.
ENERGY METER 610-PB-24	1	2540860000

Type	Qty.	Order No.
ENERGY METER 610-PB-230	1	2540870000

Accessories

DIN rail adapters
Seal
Fixing clamps

	Qty.	Order No.
ENERGY METER BRACKET L1	1	2433060000
ENERGY METER SEAL L96-2	1	2495610000
ENERGY METER FIXING SET	1	2433030000

	Qty.	Order No.
ENERGY METER BRACKET L1	1	2433060000
ENERGY METER SEAL L96-2	1	2495610000
ENERGY METER FIXING SET	1	2433030000

Note

Note

Note

Energy meters for front panel mounting

Energy Meter 700-PN-24

Energy Meter 700-PN-230



Technical data

Measurement range, voltage L-N, AC
Measurement range, voltage L-L, AC
Surge voltage category
Supply voltage
Three-wire system
Four-wire system
Quadrants
Sampling frequency 50/60 Hz
Continuous measurements
Effective value from the period (50/60 Hz)
Measurement result per second
Residual current measuring
Harmonics, per order / voltage
Harmonics, per order / current
Unbalanced
Positive, negative and zero system
Measuring accuracy for voltage
Measuring accuracy for current
Measurement accuracy for active energy (kWh, .../5 A)
Number of digital inputs
Number of digital outputs
Number of pulse outputs
Current-measuring channels
Temperature input
Memory; minimum and maximum values
Memory size
Interface
Protocol

277 V
480 V
300 V CAT III
24 - 90 V AC (50/60 Hz), 24 - 90 V DC
Yes
Yes
4
25.6 kHz
Yes
10 / 12
5
Yes
1-40.
1-40.
No
Yes
0.2 %
0.2 %
Class 0.5S
3
5
5
4 + 2
Yes
Yes
RS485: 9.6 - 921.6 kbps, Ethernet, Web server
PROFINET, Modbus RTU, Modbus TCP/IP, Modbus RTU over Ethernet, SNMP

277 V
480 V
300 V CAT III
90 - 277 V AC (50/60 Hz), 90 - 250 V DC
Yes
Yes
4
25.6 kHz
Yes
10 / 12
5
Yes
1-40.
1-40.
No
Yes
0.2 %
0.2 %
Class 0.5S
3
5
5
4 + 2
Yes
Yes
RS485: 9.6 - 921.6 kbps, Ethernet, Web server
PROFINET, Modbus RTU, Modbus TCP/IP, Modbus RTU over Ethernet, SNMP

Note

Ordering data

Note

Type	Qty.	Order No.
ENERGY METER 700-PN-24	1	2500870000

Type	Qty.	Order No.
ENERGY METER 700-PN-230	1	2500890000

Accessories

DIN rail adapters
Seal
Fixing clamps

	Qty.	Order No.
ENERGY METER BRACKET L1	1	2433060000
ENERGY METER SEAL L96-2	1	2495610000
ENERGY METER FIXING SET	1	2433030000

	Qty.	Order No.
ENERGY METER BRACKET L1	1	2433060000
ENERGY METER SEAL L96-2	1	2495610000
ENERGY METER FIXING SET	1	2433030000

Note

Energy meters for front panel mounting

Energy Meter 750-24

Energy Meter 750-230



Technical data

Measurement range, voltage L-N, AC	277 V
Measurement range, voltage L-L, AC	480 V
Surge voltage category	300 V CAT III
Supply voltage	24 - 90 V AC (50/60 Hz), 24 - 90 V DC
Three-wire system	Yes
Four-wire system	Yes
Quadrants	4
Sampling frequency 50/60 Hz	25.6 kHz
Continuous measurements	Yes
Effective value from the period (50/60 Hz)	10 / 12
Measurement result per second	5
Residual current measuring	Yes
Harmonics, per order / voltage	1-40.
Harmonics, per order / current	1-40.
Unbalanced	No
Positive, negative and zero system	Yes
Measuring accuracy for voltage	0.2 %
Measuring accuracy for current	0.2 %
Measurement accuracy for active energy (kWh, .../5 A)	Class 0.5S
Number of digital inputs	3
Number of digital outputs	5
Number of pulse outputs	5
Current-measuring channels	4 + 2
Temperature input	Yes
Memory; minimum and maximum values	Yes
Memory size	256 MB
Interface	RS485: 9.6 - 921.6 kbps, Ethernet, Web server/e-mail
Protocol	Modbus RTU, Modbus-Gateway, Modbus TCP/IP, Modbus RTU over Ethernet, SNMP, BACnet (optional)
Note	

Measurement range, voltage L-N, AC	277 V
Measurement range, voltage L-L, AC	480 V
Surge voltage category	300 V CAT III
Supply voltage	24 - 90 V AC (50/60 Hz), 24 - 90 V DC
Three-wire system	Yes
Four-wire system	Yes
Quadrants	4
Sampling frequency 50/60 Hz	25.6 kHz
Continuous measurements	Yes
Effective value from the period (50/60 Hz)	10 / 12
Measurement result per second	5
Residual current measuring	Yes
Harmonics, per order / voltage	1-40.
Harmonics, per order / current	1-40.
Unbalanced	No
Positive, negative and zero system	Yes
Measuring accuracy for voltage	0.2 %
Measuring accuracy for current	0.2 %
Measurement accuracy for active energy (kWh, .../5 A)	Class 0.5S
Number of digital inputs	3
Number of digital outputs	5
Number of pulse outputs	5
Current-measuring channels	4 + 2
Temperature input	Yes
Memory; minimum and maximum values	Yes
Memory size	256 MB
Interface	RS485: 9.6 - 921.6 kbps, Ethernet, Web server/e-mail
Protocol	Modbus RTU, Modbus-Gateway, Modbus TCP/IP, Modbus RTU over Ethernet, SNMP, BACnet (optional)
Note	

Measurement range, voltage L-N, AC	277 V
Measurement range, voltage L-L, AC	480 V
Surge voltage category	300 V CAT III
Supply voltage	90 - 277 V AC (50/60 Hz), 90 - 250 V DC
Three-wire system	Yes
Four-wire system	Yes
Quadrants	4
Sampling frequency 50/60 Hz	25.6 kHz
Continuous measurements	Yes
Effective value from the period (50/60 Hz)	10 / 12
Measurement result per second	5
Residual current measuring	Yes
Harmonics, per order / voltage	1-40.
Harmonics, per order / current	1-40.
Unbalanced	No
Positive, negative and zero system	Yes
Measuring accuracy for voltage	0.2 %
Measuring accuracy for current	0.2 %
Measurement accuracy for active energy (kWh, .../5 A)	Class 0.5S
Number of digital inputs	3
Number of digital outputs	5
Number of pulse outputs	5
Current-measuring channels	4 + 2
Temperature input	Yes
Memory; minimum and maximum values	Yes
Memory size	256 MB
Interface	RS485: 9.6 - 921.6 kbps, Ethernet, Web server/e-mail
Protocol	Modbus RTU, Modbus-Gateway, Modbus TCP/IP, Modbus RTU over Ethernet, SNMP, BACnet (optional)
Note	

Ordering data

Note	
-------------	--

Type	Qty.	Order No.
ENERGY METER 750-24	1	2540900000

Type	Qty.	Order No.
ENERGY METER 750-230	1	2540910000

Accessories

DIN rail adapters	
Seal	
Fixing clamps	

	Qty.	Order No.
ENERGY METER BRACKET L1	1	2433060000
ENERGY METER SEAL L96-2	1	2495610000
ENERGY METER FIXING SET	1	2433030000

	Qty.	Order No.
ENERGY METER BRACKET L1	1	2433060000
ENERGY METER SEAL L96-2	1	2495610000
ENERGY METER FIXING SET	1	2433030000

Note	
-------------	--

Note	
-------------	--

Note	
-------------	--

Energy meters for front panel mounting

Power Monitor

Power Monitor 51 A



Technical data

Supply voltage	100...240 V AC, 100...300 V DC	85...264 VAC, 100...300 V DC
General data		
Measurement accuracy for active energy (kWh, .../5 A)	1% for the calculated values	1% for the calculated values
Measuring-voltage input		
Three-wire system	Yes	Yes
Four-wire system	Yes	Yes
Measurement range, voltage L-L, AC	0...500 V	0...500 V
Measurement range, voltage L-N, AC	0...250 V (1P3W), 0...289 V (3P4W)	0...250 V (1P3W), 0...289 V (3P4W)
Measuring accuracy for voltage	1 %	0.5 %
Measuring-current input		
Rated current	1 / 5 A	1 / 5 A
Residual current measuring	No	No
Measuring accuracy for current	0.5 %	0.5 %
Current-measuring channels	3	4
inputs / outputs		
Number of digital inputs		2
Number of digital outputs		2
Communication		
Interface	RS485: Autobaud, 9.6 - 115.2 kbps (pluggable screw terminals)	RS485: Autobaud, 9.6 - 115.2 kbps (pluggable screw terminals), USB
Protocol	Modbus RTU	Modbus RTU
Mechanical specifications		
Height / Width / Depth	96 / 96 / 68 mm	96 / 96 / 68 mm
Environmental conditions		
Operating temperature	-25...55 °C	-25...55 °C
Humidity	35 % to 85 % relative humidity level	35 % to 85 % relative humidity level
Note		

Ordering data

Type	Qty.	Order No.	Type	Qty.	Order No.
POWER MONITOR	1	1423550000	POWER MONITOR 51A	1	1470260000

Accessories

	Qty.	Order No.		Qty.	Order No.
DIN rail adapters			POWER MONITOR BRACKET	1	2091060000
			POWER MONITOR BRACKET	1	2091060000

Note					
-------------	--	--	--	--	--

Holistic analysis of the quality of electrical supply networks

Energy analysers for transparency and improved plant availability



The quality of the electrical network is an important parameter for the effectiveness and availability of industrial plants and production facilities. The Energy Analyser 750 is the first step towards increased added value and is particularly suitable for monitoring power quality according to common standards such as EN 50160, IEEE 519 or IEC 61000-2-4.

An increasing number of non-linear consumers and plant components are being used in production facilities. They have an impact on, for example, network frequency, phase shift and the amplitude of phases. This influences the quality of the electrical energy and thus the uptime of the plant. The new Energy Analyser 750 measures all quality parameters of the electrical supply network, from the symmetry to transients and many other parameters besides.

Integrated monitoring of residual current

The built-in residual current measurement highlights creeping increases in residual current before fuses or residual current detectors switch off the section of the system. This maximizes operating times.

Large, clear display

The large QVGA colour display on the device clearly visualises all measurement parameters and allows convenient adjustment of the system parameters.

Top-hat rail devices for simple requirements

For less comprehensive measurements, we offer the Energy Analyser D550, a very small device for installation on standard DIN rails.



With the Energy Analyser 750, you can carry out comprehensive checks on the quality of the electrical energy in your production facility and initiate optimization steps to maximize the effectiveness and availability of your plant. Important events can be recorded as required.

Continuously monitoring voltage quality

Standard-compliant measurements with the Energy Analyser 750

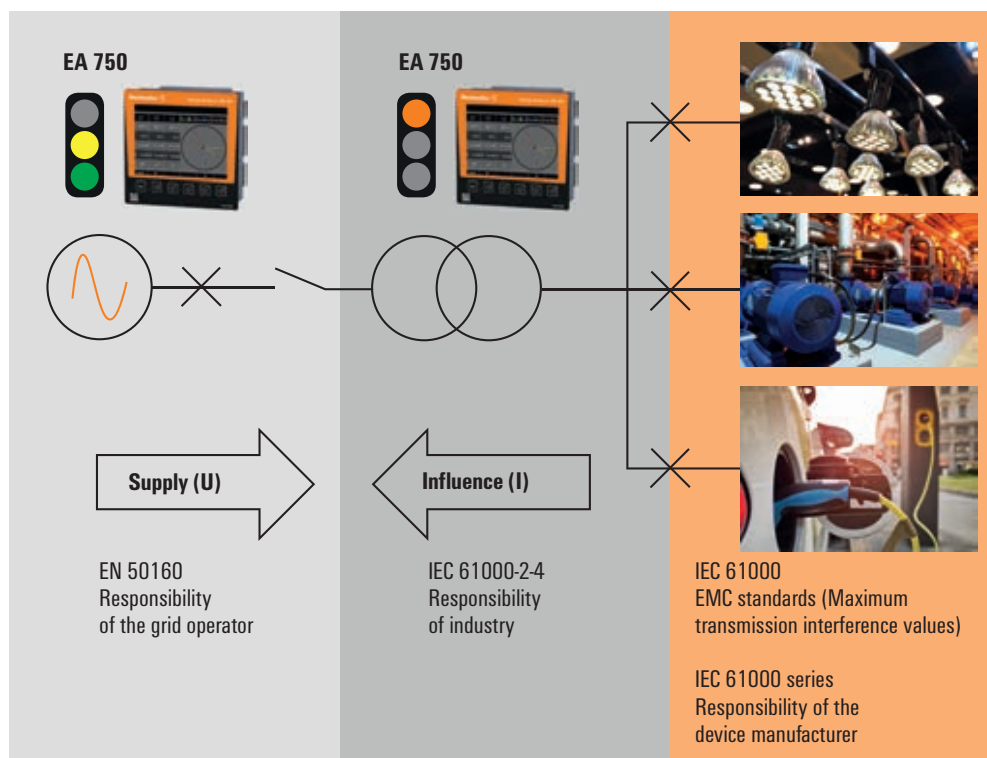

Power quality – standards and guidelines

Within Europe, EN 50160 is the standard for describing the quality of an electrical power supply. The standard mainly describes the characteristics of the supply voltage at the point of supply to the customer in public low and medium voltage networks under normal operating conditions. EN 50160 applies to the grid voltage, i.e. the voltage measured at the point of connection with the grid. A voltage distortion in the public grid distorts the voltage in the industrial grid, and should therefore be monitored continuously.

The IEC 61000-2-4 standard defines numerical thresholds for industrial and non-public electricity distribution systems with nominal voltages of up to 35 kV. The IEC 61000-2-4 standard should apply to the quality of the voltage at the point of supply to the consumer. That is why it serves as the basis for many product and machinery design standards.

It defines the immunity levels for voltage distortions that machinery and systems in industrial enterprises need to be able to withstand.

If the level is exceeded, this may result in outages that the machinery or system supplier is not liable for. Monitoring in accordance with IEC 61000-2-4 is therefore advisable. New standards such as EN 50600-2-2 for electrical systems in data processing centres also require voltage quality in accordance with EN 50160 and IEC 61000-2-4.

The Energy Analyser 750 facilitates the comprehensive monitoring of specific parameters of voltage quality, and supports compliance with all required standards.

Energy analysis instruments

Energy Analyser D550-24

Energy Analyser D550-230



Technical data

Measurement range, voltage L-N, AC	277 V
Measurement range, voltage L-L, AC	480 V
Surge voltage category	300 V CAT III
Supply voltage	20 ... 50 V AC $\pm 10\%$, 20 ... 70 V DC $\pm 10\%$
Three-wire system	Yes
Four-wire system	Yes
Quadrants	4
Sampling frequency 50/60 Hz	20 kHz
Continuous measurements	Yes
Effective value from the period (50/60 Hz)	10 / 12
Measurement result per second	5
Residual current measuring	No
Harmonics, per order / voltage	1-40.
Harmonics, per order / current	1-40.
Unbalanced	Yes
Positive, negative and zero system	Yes
Measuring accuracy for voltage	0.2 %
Measuring accuracy for current	0.25 %
Measurement accuracy for active energy (kWh, .../5 A)	Class 0.5S
Number of digital inputs	2
Number of digital outputs	2
Number of pulse outputs	2
Current-measuring channels	4
Temperature input	Yes
Memory; minimum and maximum values	Yes
Memory size	128 MB
Interface	RS232: 9.6 - 115.2 kbps, RS485: 9.6 - 921.6 kbps, Ethernet, Web server/e-mail
Protocol	Modbus RTU, Modbus-Gateway, Modbus TCP/IP, Modbus RTU over Ethernet, SNMP, BACnet (optional)
Note	

Measurement range, voltage L-N, AC	277 V
Measurement range, voltage L-L, AC	480 V
Surge voltage category	300 V CAT III
Supply voltage	20 ... 50 V AC $\pm 10\%$, 20 ... 70 V DC $\pm 10\%$
Three-wire system	Yes
Four-wire system	Yes
Quadrants	4
Sampling frequency 50/60 Hz	20 kHz
Continuous measurements	Yes
Effective value from the period (50/60 Hz)	10 / 12
Measurement result per second	5
Residual current measuring	No
Harmonics, per order / voltage	1-40.
Harmonics, per order / current	1-40.
Unbalanced	Yes
Positive, negative and zero system	Yes
Measuring accuracy for voltage	0.2 %
Measuring accuracy for current	0.25 %
Measurement accuracy for active energy (kWh, .../5 A)	Class 0.5S
Number of digital inputs	2
Number of digital outputs	2
Number of pulse outputs	2
Current-measuring channels	4
Temperature input	Yes
Memory; minimum and maximum values	Yes
Memory size	128 MB
Interface	RS232: 9.6 - 115.2 kbps, RS485: 9.6 - 921.6 kbps, Ethernet, Web server/e-mail
Protocol	Modbus RTU, Modbus-Gateway, Modbus TCP/IP, Modbus RTU over Ethernet, SNMP, BACnet (optional)
Note	

Measurement range, voltage L-N, AC	277 V
Measurement range, voltage L-L, AC	480 V
Surge voltage category	300 V CAT III
Supply voltage	95 - 240 V AC, 135 - 340 V DC
Three-wire system	Yes
Four-wire system	Yes
Quadrants	4
Sampling frequency 50/60 Hz	20 kHz
Continuous measurements	Yes
Effective value from the period (50/60 Hz)	10 / 12
Measurement result per second	5
Residual current measuring	No
Harmonics, per order / voltage	1-40.
Harmonics, per order / current	1-40.
Unbalanced	Yes
Positive, negative and zero system	Yes
Measuring accuracy for voltage	0.2 %
Measuring accuracy for current	0.25 %
Measurement accuracy for active energy (kWh, .../5 A)	Class 0.5S
Number of digital inputs	2
Number of digital outputs	2
Number of pulse outputs	2
Current-measuring channels	4
Temperature input	Yes
Memory; minimum and maximum values	Yes
Memory size	128 MB
Interface	RS232: 9.6 - 115.2 kbps, RS485: 9.6 - 921.6 kbps, Ethernet, Web server/e-mail
Protocol	Modbus RTU, Modbus-Gateway, Modbus TCP/IP, Modbus RTU over Ethernet, SNMP, BACnet (optional)
Note	

Ordering data

Note	
------	--

Type	Qty.	Order No.
ENERGY ANALYSER D550-24	1	2489780000

Type	Qty.	Order No.
ENERGY ANALYSER D550-230	1	2425510000

Accessories

--	--	--

Type	Qty.	Order No.

Type	Qty.	Order No.

Note	
------	--

--	--	--

--	--	--

Energy analysis instruments

Energy Analyser 550-24

Energy Analyser 550-230



Technical data

Measurement range, voltage L-N, AC
Measurement range, voltage L-L, AC
Surge voltage category
Supply voltage
Three-wire system
Four-wire system
Quadrants
Sampling frequency 50/60 Hz
Continuous measurements
Effective value from the period (50/60 Hz)
Measurement result per second
Residual current measuring
Harmonics, per order / voltage
Harmonics, per order / current
Unbalanced
Positive, negative and zero system
Measuring accuracy for voltage
Measuring accuracy for current
Measurement accuracy for active energy (kWh, .../5 A)
Number of digital inputs
Number of digital outputs
Number of pulse outputs
Current-measuring channels
Temperature input
Memory; minimum and maximum values
Memory size
Interface
Protocol
Note

417 V
720 V
600 V CAT III
48...110 V AC, 24...150 V DC
Yes
Yes
4
20 kHz
Yes
10 / 12
5
Yes
1-63.
1-63.
Yes
Yes
0.1 %
0.2 %
Class 0.2S
2
2
2
4 + 2
Yes
Yes
256 MB
RS485: 9.6 - 921.6 kbps, Profibus DP, Ethernet, Web server/e-mail
Modbus RTU, Modbus-Gateway, Modbus TCP/IP, Modbus RTU over Ethernet, SNMP, Profibus DP V0, BACnet (optional)
Note

417 V
720 V
600 V CAT III
95 - 240 V AC, 80 - 300 V DC
Yes
Yes
4
20 kHz
Yes
10 / 12
5
Yes
1-63.
1-63.
Yes
Yes
0.1 %
0.2 %
Class 0.2S
2
2
2
4 + 2
Yes
Yes
256 MB
RS485: 9.6 - 921.6 kbps, Profibus DP, Ethernet, Web server/e-mail
Modbus RTU, Modbus-Gateway, Modbus TCP/IP, Modbus RTU over Ethernet, SNMP, Profibus DP V0, BACnet (optional)
Note

Ordering data

Note

Type	Qty.	Order No.
ENERGY ANALYSER 550-24	1	2602580000

Type	Qty.	Order No.
ENERGY ANALYSER 550-230	1	2425500000

Accessories

DIN rail adapters
Seal

	Qty.	Order No.
ENERGY METER BRACKET B1	1	2433040000
ENERGY METER SEAL L144	1	2495630000

	Qty.	Order No.
ENERGY METER BRACKET B1	1	2433040000
ENERGY METER SEAL L144	1	2495630000

Note

Note

Note

Energy analysis instruments

Energy Analyser 750-24

Energy Analyser 750-230



Technical data

Measurement range, voltage L-N, AC
Measurement range, voltage L-L, AC
Surge voltage category
Supply voltage
Three-wire system
Four-wire system
Quadrants
Sampling frequency 50/60 Hz
Continuous measurements
Effective value from the period (50/60 Hz)
Measurement result per second
Residual current measuring
Harmonics, per order / voltage
Harmonics, per order / current
Unbalanced
Positive, negative and zero system
Measuring accuracy for voltage
Measuring accuracy for current
Measurement accuracy for active energy (kWh, .../5 A)
Number of digital inputs
Number of digital outputs
Number of pulse outputs
Current-measuring channels
Temperature input
Memory; minimum and maximum values
Memory size
Interface
Protocol
Note

347 V
600 V
600 V CAT III
48...110 V AC, 24...150 V DC
Yes
Yes
4
25.6 kHz
Yes
10 / 12
5
Yes
1-63.
1-63.
Yes
Yes
0.1 %
0.1 %
Class 0.2S
2
2
2
4 + 2
Yes
Yes
256 MB
RS485: 9.6 - 921.6 kbps, Profibus DP, Ethernet, Web server/e-mail
Modbus RTU, Modbus-Gateway, Modbus TCP/IP, Modbus RTU over Ethernet, SNMP, Profibus DP V0, BACnet (optional)
Note

347 V
600 V
600 V CAT III
95 - 240 V AC, 80 - 300 V DC
Yes
Yes
4
25.6 kHz
Yes
10 / 12
5
Yes
1-63.
1-63.
Yes
Yes
0.1 %
0.1 %
Class 0.2S
2
2
2
4 + 2
Yes
Yes
256 MB
RS485: 9.6 - 921.6 kbps, Ethernet, Profibus DP, Web server/e-mail
Modbus RTU, Modbus-Gateway, Modbus TCP/IP, Modbus RTU over Ethernet, SNMP, Profibus DP V0, BACnet (optional)
Note

Ordering data

Note

Type	Qty.	Order No.
ENERGY ANALYSER 750-24	1	2534160000

Type	Qty.	Order No.
ENERGY ANALYSER 750-230	1	2534130000

Accessories

DIN rail adapters
Seal

	Qty.	Order No.
ENERGY METER BRACKET B1	1	2433040000
ENERGY METER SEAL L144	1	2495630000

	Qty.	Order No.
ENERGY METER BRACKET B1	1	2433040000
ENERGY METER SEAL L144	1	2495630000

Note

Note

Note

Provide measurement data efficiently and conveniently

Our energy logger collects consumption and process data



Integrated temperature measurement

The Energy Logger D550 has an input for temperature measurement. This saves costs in setting up an infrastructure for the measurement of process parameters

Integrated ModBus interface

As well as the consumption data of simple measuring devices, measurement values from devices with a ModBus interface can also be forwarded over a network.

Integrated data memory

Data can be saved long-term in the device's built-in 32 MB memory.

As well as the consumption of electrical energy, the consumption of, for example, compressed air, water and gas can also be optimised. Energy Logger D550 enables the provision of cross-plant measurement data in the network.

Measuring devices with a simple S0 interface are widespread. But they cannot transfer measured values direct into the internal network. Therefore, a gateway is required for each measuring device. The Energy Logger D550 can collect and save impulse signals from up to 15 measurement devices and forwards them via a LAN interface.

This particularly compact Energy Logger D550 is the cost-effective solution to simplify and accelerate the collecting and forwarding of consumption and process data.

Energy logger

Energy Logger D550



Technical data

Surge voltage category
Supply voltage
Operating-hours counter
Number of digital inputs
Number of digital outputs
Memory size
Software
Interfaces
Interface
Protocol
Protocol
Note

300 V CAT III
20 - 250 V AC, 20 - 300 V DC
Yes
15
3
32 MB
ecoExplorer go®
RS485: 9.6 - 921.6 kbps, Ethernet
Modbus RTU, Modbus-Gateway, Modbus TCP/IP, Modbus RTU over Ethernet, SNMP

Ordering data

Note

Type	Qty.	Order No.
ENERGY LOGGER D550	1	2425520000

Accessories

SO module 1.3 kOhm		
--------------------	--	--

	Qty.	Order No.
ENERGY LOGGER SO MODULE	1	2446170000

Note

More Performance. Simplified.

u-remote.

u-remote from Weidmüller is the reliable interface between field bus and field level in automation. The modular system is based on various components: a field bus coupler, up to 64 I/O modules, optional power-feed modules and a wealth of accessories, such as markers and terminating elements.

The field bus coupler is the central link between the various field bus standards and the u-remote system bus. At the same time, up to 64 I/O modules are supplied via its integrated power contacts. The well-engineered technology of the connection system enables 2 x 10 A to be supplied for the input and output modules and the system voltage to be fully supplied through the field bus coupler.

Every field bus coupler provides direct access to the u-remote system via a web server without additional software having to be installed. This means that the system can be parameterised and its configuration checked. Inputs and outputs can also be checked or influenced. The connection may take the form of an Ethernet-based field bus or micro USB.

The u-remote field bus couplers are integrated in the standard simple manner. The corresponding development environments of the control systems and the device description files available online, e.g. GSD, ESD, EDS oder XML, can be used to easily perform the necessary settings.

The modularly structured I/O modules are unique in that they allow the sensor and actuator wiring to be designed in both a robust and plug-in manner. This allows the electronics to be replaced at any time even with permanent wiring without downstream I/O module operations being affected. This achieves an invaluable time saving, in terms of both wiring inaccessible cabinets and rapidly replacing sensors. Thanks to the "PUSH IN" technology for up to 1.5 mm², in their narrowest form of 11.5 mm, the modularly structured u-remote I/O modules can be used for all sensor and actuator connections with a very high connection density. A clear status and diagnosis display on the connection also ensures rapid and precise checks for individual sensors and actuators.



Record electrical data of single consumers in real time

Energy consumption measurement and monitoring with u-remote



Direct measurement – direct saving

Currents of up to 1 A or 5 A can be measured directly without additional components such as pluggable or retrofit current transformers.

Integrated pre-processing of measurement data

A wide range of parameters allow an applicationspecific configuration for the measurement, analysis and further processing of the raw data. With this a lot of consumer-specific characteristics can be transferred directly to the process data image.

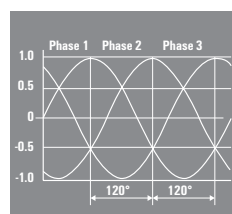

Gain transparency about the consumption data for your machines and systems. u-remote integrates individual data recording into your plant automation system.

Rising energy costs require sustainable energy management. The aim is to tailor the operation of individual machines and processes or even whole plants to optimum energy usage. This means recording and analysing the consumption data for all components. The new u-remote energy measurement module is used to record and process data from single- or three-phase AC consumers up to a rated voltage of 300 V_{eff} AC (L-N). Reactive, apparent and active power, energy consumption, phase angle and many more electrical characteristics can be measured or calculated directly with the module and transferred to higher-level controllers

or control systems via the process data. The power measurement module can easily be integrated into existing automation solutions using u-remote.

With a width of just 11.5 mm, an individual consumer can be connected to record measured values for voltages and currents – with a free choice of communication protocol.

Even without any process interruption using split-core current transformers or Rogowski Coils which are placed around the existing conductors or current bars.

Power measurement module

Power measurement via 1- or 3-phase, rated voltage to 300 V_{eff}

The power measurement module is used for recording and processing of currents and voltages on one or three-phase loads up to a rated voltage of 300 V_{eff} AC (phase to neutral conductor). Reactive, apparent harmonic and active power, energy consumption, phase angle and many other electrical parameters are measured or calculated by the module. The transmitted data via the process data of the different fieldbuses can be selected via parameters.

The Power measurement module can be easily integrated into existing automation solutions with u-remote. Using split-core current transformers it is not even necessary to intervene in the existing installation. Currents from 1 A or up to 5 A can be measured directly, higher currents can be measured with split-core or plug-in current transformers from Weidmüller.

UR20-3EM-230V-AC block diagram example

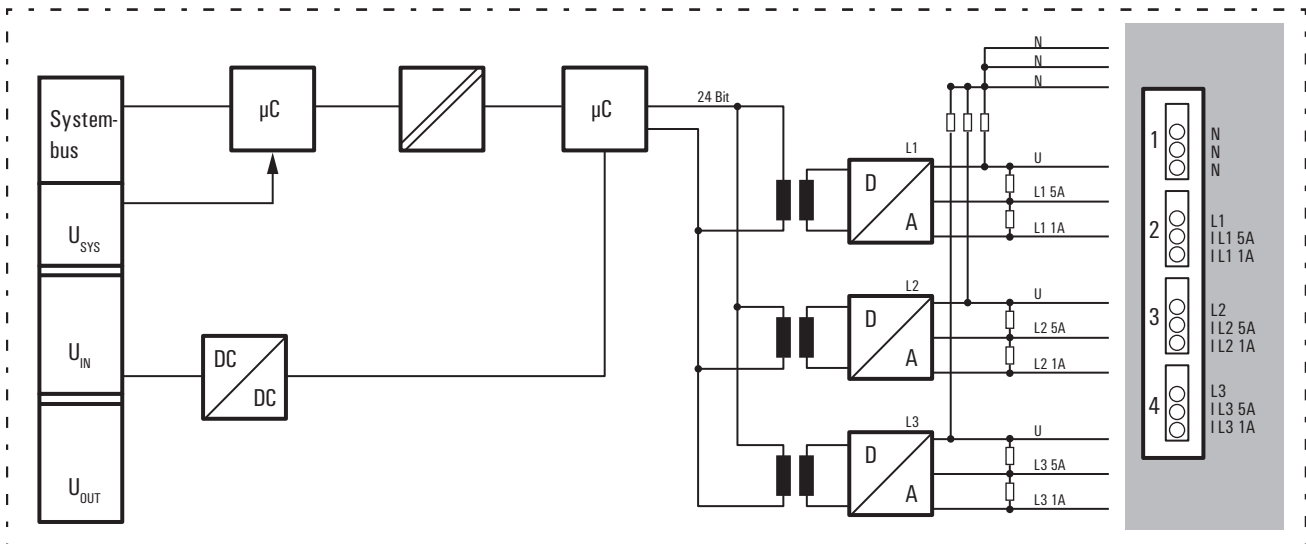

3EM-230V-AC

- 1- or 3-phase power measurement for 1 A or 5 A (with or without transformer)
- Measurement in the phase conductor
- 16 bit resolution
- Power-/ reactive power measurement
- Energy meter Active / reactive
- Power factor
- Frequency measurement 45 ... 65 Hz
- Analysis of 31 harmonics

Technical data

System data	
Interface	u-remote system bus
Transmission speed of system bus, max.	48 Mbit
Galvanic isolation	500 V DC between the current paths
Supply	
Supply voltage	24 V DC +20%/-15%, via the system bus
Current consumption I_m (power segment of the field bus coupler), typ.	8 mA
Current consumption I_m (the respective power segment)	12 mA
Analogue inputs	
Number	3
Rated voltage	300 V _{eff} (L-N)
Resolution	16 bit per channel (internal 24 bit)
Sampling rate of current measurement	3,300 samples/s
Frequency of the supply system	45...65 Hz
Analysis of harmonic	31 (Blackmann-Harris Window)
Power rating	0...1 A / 0...5 A AC
Insulation	1.5 kV _{eff} (input / system)
Nominal peak voltage	4 kV
Category for voltage measurements	CAT II (IEC 61010 Part 1)
Measurement method	High Resolution Delta Sigma (current measurement in outer conductor)
Measurement accuracy	0.5% in relation to final value (U / I), 1% for the calculated values
Connectable converter ratios	1 ... 1000
Input impedance voltage	2.4 MΩ per channel
Measurement resistance (shunt)	4 mΩ (at 5 A), 20 mΩ (at 1 A)
General data	
Weight	90 GRM
Dimensions H x W x D	120 mm / 11.5 mm / 76 mm
Note	

Ordering data

Module variants	
	Power measurement module, 3 channels
Note	

Accessories

	Coding elements
	Termination kit
	Swivel marker
	Connection marker for pusher custom printing
	Connection marker for pusher neutral
	Module marker for custom printing
	Module marker for neutral
	Thermotransfer version (Material: Polyester)
	Thermotransfer version (material: polyester)
	Paper version for Laserprinter
Replacement parts	
	Electronic module
	Basic module
	Plug-in connector unit
Note	

UR20-3EM-230V-AC



Type		
UR20-3EM-230V-AC	Qty. 1	Order No. 2007420000
Type		
KOSM BHZ5.00	Qty. 100	Order No. 1483050000
UR20-EBK-ACC	Qty. 5	Order No. 1346610000
UR20-SM-ACC	Qty. 20	Order No. 1339920000
PM 2.7/2.6 MC SDR	Qty. 192	Order No. 1323700000
PM 2.7/2.6 MC NE WS	Qty. 960	Order No. 1323710000
DEK 5/8-11.5 MC SDR	Qty. 100	Order No. 1341610000
DEK 5/8-11.5 MC NE WS	Qty. 500	Order No. 1341630000
THM UR20 GE	Qty. 1	Order No. 1429910000
THM UR20 WS	Qty. 1	Order No. 1429420000
ESO UR20 DIN A4 WS	Qty. 10	Order No. 1429430000
UR20-EM-2007420000-SP	Qty. 1	Order No. 1562270000
UR20-BM-SP	Qty. 5	Order No. 1350930000
UR20-PK-2007420000-SP	Qty. 5	Order No. 2068630000

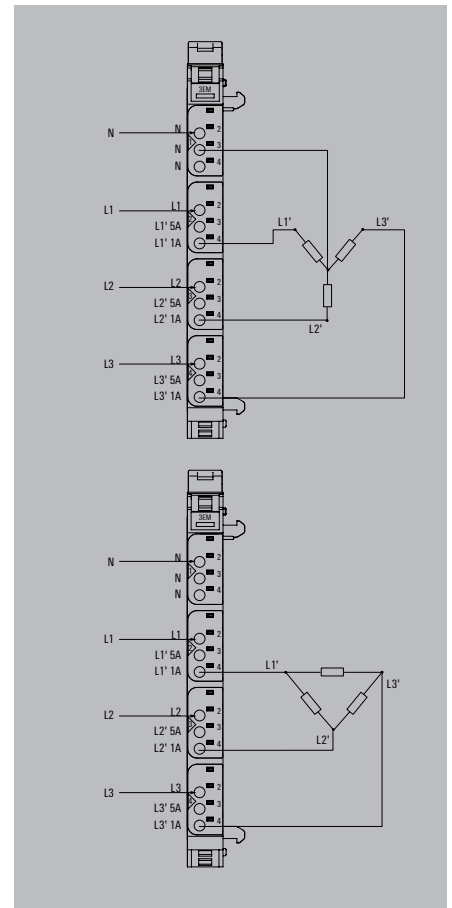

EMC	EN 61000
ATEX	EN 60079
UL	UL 508
MSIP	MSIP-REM-WMG-2007420000
ABS (American Bureau of Shipping)	
BSH (Federal Maritime and Hydrographic Agency)	
BV (Bureau Veritas)	
DNV GL (Det Norske Veritas) (Germanischer Lloyd)	
LR (Lloyd's Register)	
RINA (Registro Italiano Navale)	

ModbusTCP field bus coupler

Web server tool; two RJ45 ports; 10/100 Mbps

ModbusTCP

System safety around the globe is provided by the ModbusTCP version, which is stated in IEC 61158 as an Industrial Ethernet Standard. The UR20-FBC-MOD-TCP from Weidmüller is a field bus coupler designed in accordance with IEC 61158. With options for connecting up to 64 u-remote participants, it serves as the head module for the u-remote system bus.

The coupler can be activated with a system-independent web server application via the USB service interface or the Ethernet ports. All information, such as diagnoses, status values and parameters, can therefore be read out. All

connected inputs can also be simulated or outputs set. The system's initial power supply is already integrated in the field bus coupler. Power is supplied via two 4-pin connectors, separated into the input and output current paths.

Since the ModbusTCP products from Weidmüller make full use of all the latest technological possibilities, such as diagnosis options, they actively support your application in the most important tasks – from engineering and commissioning to fault diagnosis.

More Performance. Simplified.

Block diagram UR20-FBC-MOD-TCP

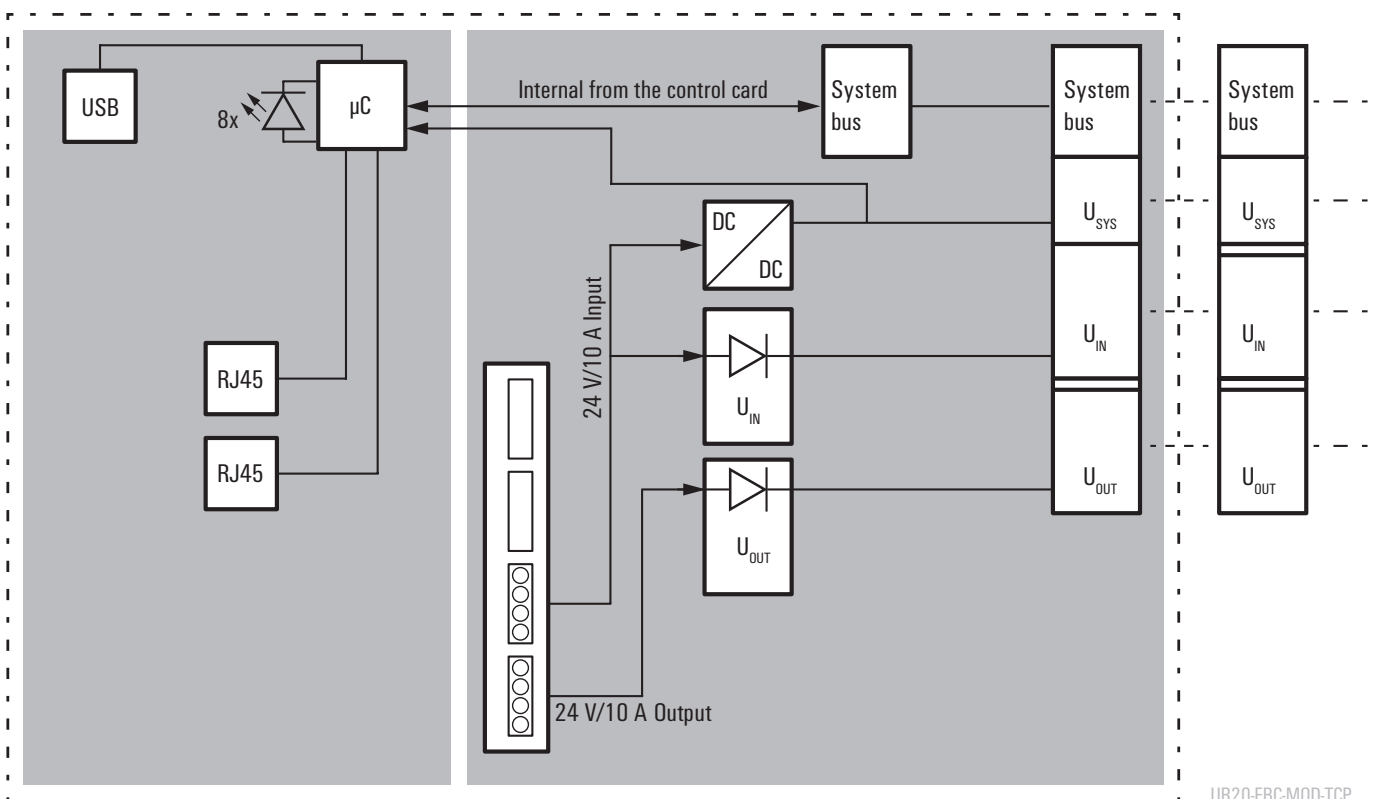

UR20-FBC-MOD-TCP

ModbusTCP V2

- Dual LAN mode
- 2 x 10 A current path
- Various Modbus services
- Web server
- System supply for 64 I/O modules
- Temperature range: -20 - +60 °C

UR20-FBC-MOD-TCP-V2



Technical data

System data	
Connection type	2 x RJ45 plug-in connectors
Field bus protocol	Modbus/TCP
Process data	8 kByte
Parameter data	1024 Byte
Diagnostic data	1024 Byte
max. number of modules	64
Configuration interface	Micro USB 2.0
Fieldbus interface	Full / Half Duplex, Auto MDI/X, Autonegotiation
Transmission rate of field bus, max.	100 Mbit/s
Transmission speed of system bus, max.	48 Mbit/s
Supply	
Supply voltage system and inputs	24 V DC +20%/ -15%
Supply voltage for outputs	24 V DC +20%/ -15%
Feed current for I _{in} (input current path) , max.	10 A
Feed current for I _{out} (output current path) , max.	10 A
Current consumption I _m (power segment of the field bus coupler), typ.	112 mA
General data	
Weight	316 g
Dimensions H x W x D	120 mm / 52 mm / 76 mm
Note	

Type	Qty.	Order No.
UR20-FBC-MOD-TCP-V2	1	2476450000
A termination kit (UR20-EBK-ACC) is included in the coupler package		

Ordering data

Module variants	
	Fieldbus coupler, ModbusTCP
Note	

Accessories

Replacement parts	
	Plug-in connector unit
Note	

Type	Qty.	Order No.
KOSM BH25.00	100	1483050000
UR20-EBK-ACC	5	1346610000
UR20-SM-ACC	20	1339920000
PM 2.7/2.6 MC SDR	192	1323700000
PM 2.7/2.6 MC NE WS	960	1323710000
DEK 5/8-11.5 MC SDR	100	1341610000
DEK 5/8-11.5 MC NE WS	500	1341630000
THM UR20 GE	1	1429910000
THM UR20 WS	1	1429420000
ESD UR20 DIN A4 WS	10	1429430000
IE-USB-A-MICRO-1.8M	1	1487980000
Note		
UR20-PK-2476450000-SP	5	2485280000
1 roll = 1000 label = 1 Qty. 1 sheet = 60 label = 1 Qty.		

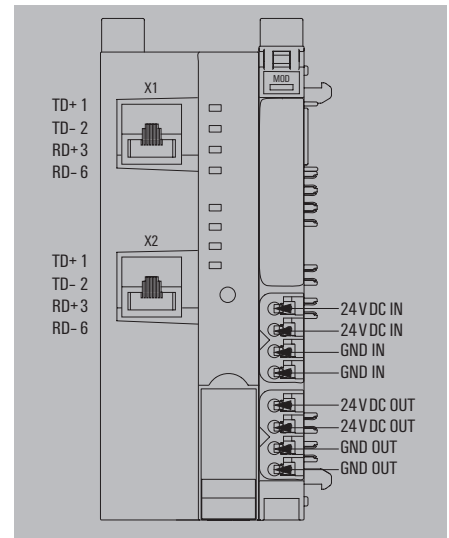

EMC	EN 61000
ATEX	EN 60079
UL	UL 508
MSIP	MSIP-REM-WMG-2476450000
ABS (American Bureau of Shipping)	
BSH (Federal Maritime and Hydrographic Agency)	
BV (Bureau Veritas)	
DNV GL (Det Norske Veritas) (Germanischer Lloyd)	
LR (Lloyd's Register)	
RINA (Registro Italiano Navale)	

Measure, convert and securely transmit currents

Current transformers and test disconnect terminals



Current transformer

Current transformers are indispensable for recording electrical parameters. They convert "high" primary currents of currently up to 4 kA from a single- or three-phase network into "low" secondary currents (5 A or 1 A). These currents can then be processed by the energy meters. Weidmüller provides several versions: such as cable-type current converters, plug-on current transformers, Rogowski system and rod current transformers.



Test disconnect terminals

Test disconnect terminals are required to safely operate current transformers. A wrong connection can destroy a current transformer! Test disconnect terminals provide a safe method to solve this problem. As a leading supplier of line connectors, Weidmüller has developed special test disconnect terminals in close cooperation with users. These stand out from the competition thanks to their space-saving design with extremely low-maintenance screw connections and a comprehensive assortment of accessories.



Connectivity Box

Our EM Connectivity Box is a perfect combination of established products from the Weidmüller range. You can choose between aluminium and plastic enclosures to meet your requirements. The enclosures are milled to fit and fitted with the requisite cable bushings. A modular terminal block to suit the measuring instruments to be fitted is already installed inside. There is also a labelled cable set which is specially adapted to the measuring equipment in question.



TCP/RTU Gateway Modbus

Flexibly connect serial and Ethernet-based Modbus participants: the gateway facilitates data communication between energy measuring devices with the serial Modbus RTU/ASCII interface and a Modbus TCP Master, for example to display and analyse energy measurement data. Special characteristics of our Modbus gateways include:

- RTU slave mode for communication between up to 16 TCP masters and 31 serial slaves.
- RTU master mode for communication between 1 serial master and up to 31 TCP slaves
- Integrated 2-port switch for setting up a line topology

Individual combination – perfect addition

Products for your comprehensive energy monitoring system



Network components for the industrial communication infrastructure

Weidmüller unmanaged switches interconnect Ethernet devices in a network and ensure the targeted distribution of data traffic. They work according to the Plug & Play principle and can therefore be used directly without any configuration needed. WLAN access point/bridge/client components allow access to energy measurement data via mobile end devices. A seamless communication between different IP networks (routing/NAT) with the highest standard of security (firewalling) is ensured with Industrial Security routers. The VDATA Cat6 surge voltage protection module was developed to protect local networks, in which for example energy measurement data is transmitted, against surge voltages.



Switched-mode power supply units

For a reliable power supply, Weidmüller also offers the PROeco and INSTAPOWER switched-mode power supply units. The switched-mode power supply units of the PROeco series impress with their compact design and are extremely economical. Thanks to their INSTA design, the single-phase switched-mode power supply units from the INSTAPOWER series are particularly small and are best suited to individual control cabinets.



ACT20C station with CMT and CML current measuring transducers

Together with the communicative current measuring transducers, the ACT20C gateway process records process and status data for the connected loads – directly from the signal converter level, regardless of the automation selected. The information can be accessed by Ethernet. Besides the real power consumption of AC/DC currents, the process data includes additional information about the operating duration and behaviour as well as device capacity. A typical field of application is, for example, the monitoring of drives: overloads and anomalies in the drive and the mechanical systems must be detected early, and performance weaknesses must be reacted to quickly – in this way, you benefit from systematic monitoring and optimisation.



ACT20C analogue signal conditioner

The communicative ACT20C-AI-AO-MTCP signal conditioner not only separates, scales and converts analogue sensor signals, it also transmits this measurement data together with further diagnosis and status information to computer and control systems via Ethernet. In this way, measurement signals are not only securely recorded in EMC-stressed plant environments, but also forwarded as digital process and status information for the 4–20 mA output signal directly to, for example, an Energy Management system. Thus, the ACT20C supports the manufacturing network.

Compatibility for different measurement environments

Current transformers from Weidmüller



Current transformers are used whenever currents cannot be measured directly. They are a special form of transformer that transforms the primary current into a (usually) smaller, standardised secondary current with a particular degree of accuracy (class), and galvanically separates the primary and secondary circuits from each other. The saturation of the core material due to physical factors gives the secondary circuit additional protection against strong currents. A fundamental distinction can be made between single-turn and coil transformers. The most common form of single-turn transformer is the plug-on current transformer. This is placed on the electrical cable, making it a transformer with a primary coil or secondary coils depending on the relevant translation.

Translation ratio

The measurement translation is the ratio between the primary rated current and the secondary rated current, and is shown on the specification plate as a non-reduced fraction. $x / 5$ A transformers are most frequently used because most measuring instruments have the higher class of accuracy with 5 A. $x / 1$ A transformers are recommended for long measurement cables for technical and above all for cost reasons. The line losses of 1 A transformers are only 4% compared to 5 A transformers. In this case, however, the measuring instruments are less precise.

Rated current

The rated (formerly: nominal) current is the figure for the primary and secondary current as stated on the specification plate (primary rated current, secondary rated current) for which the current transformer is rated. With the exception of classes 0.2 S and 0.5 S, the standardised rated currents are 10, 12.5, 15, 20, 25, 30, 40, 50, 60 and 75 A as well as decimal multiples and fractions thereof. The standardised secondary currents are 1 and 5 A.

Overview of current converters



Type	Plug-on current transformer	Rod current transformer	Three-phase current transformer
Technical information			
Application	New systems	New systems	New system
Coil	Closed	Closed	Closed
Installation	Round cable, copper busbar, terminal rail, mounting plate	Round cable (insulated), copper busbar (insulated)	Round cable, copper busbar
Primary current	60 A...4.000 A	32 A...600 A	100 A...600 A
Secondary current	5 A	1A or 5 A	5 A
Accuracy class	0,5 or 1	0,2; 0,5 or 1	1
Ambient temperature	-5...+50 °C	-5...+50 °C	-4...+40 °C
Standards	EN 61869-2	IEC 61869-2	IEC 61869-2

Selecting the correct primary rated current is important for the accuracy of measurements. A ratio that is directly above the measured or defined current (I_n) is recommended – for example: $I_n = 1.154 \text{ A}$, chosen transformer ratio = 1.250/5.

The rated current can also be defined based on the following considerations:

- Transformer rated current multiplied by approx. 1.1 (nearest transformer value)
- The fuse rated current (transformer rated current) of the measured sub-system (low-voltage distribution system, sub-distributor)
- Actual rated current multiplied by 1.2 (recommended in case the actual current is much lower than the transformer value or fuse rated current)

An overly large current transformer is to be avoided as otherwise the accuracy of measurements is significantly reduced in some cases for relatively small currents (in relation to the primary rated current).

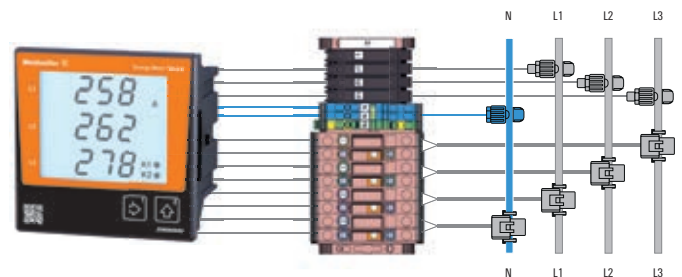

Split-core current transformer	Wire-wrap current transformer	System with Rogowski coil and analysis unit
Retrofitting	New systems	Retrofitting
Detachable	Closed	Detachable with bayonet joint
Round cable (insulated), copper busbar (insulated)		Round cable, copper busbar
50 A...1.500 A	5 A...20 A	5.000 A
1A or 5 A	5 A	1 A
0,5; 1 or 3	1	0,5
-5...+55 °C	-5...+40°C	-40...+80 °C
EN 61869-2	IEC 61869-2	IEC 61010 / EN 61869-2

Plug-on current transformer

The CMA-31 series current transformer can measure primary currents in the range 60 A to 750 A and transform to a current up to 5 A on the secondary side. The transformer is equipped with a maintenance-free spring balancer cage clamp and is especially suitable for installation on current bars and on cables of new systems.

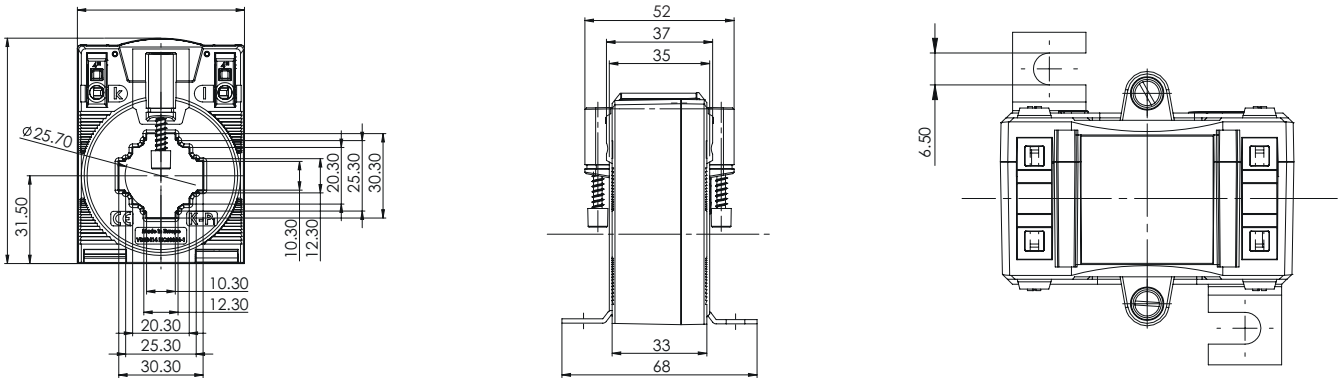

Ordering data

Order No.	Type	Primary current	Secondary current max.	Tolerance class	Load	Round conductor	Rail	Qty.
2421380000	CMA-31-60-5A-1,25VA-1	60 A	5 A	1	1.25 VA	25.70 mm	20 x 20 mm, 25 x 12 mm, 30 x 10 mm	1
1482040000	CMA-31-75-5A-2,5VA-1	75 A	5 A	1	2.5 VA	25.70 mm	20 x 20 mm, 25 x 12 mm, 30 x 10 mm	1
1482030000	CMA-31-100-5A-2,5VA-1	100 A	5 A	1	2.5 VA	25.70 mm	20 x 20 mm, 25 x 12 mm, 30 x 10 mm	1
2421030000	CMA-31-150-5A-2,5VA-0,5	150 A	5 A	0,5	2.5 VA	25.70 mm	20 x 20 mm, 25 x 12 mm, 30 x 10 mm	1
2420960000	CMA-31-150-5A-5VA-1	150 A	5 A	1	5 VA	25.70 mm	20 x 20 mm, 25 x 12 mm, 30 x 10 mm	1
2421020000	CMA-31-200-5A-2,5VA-0,5	200 A	5 A	0,5	2.5 VA	25.70 mm	20 x 20 mm, 25 x 12 mm, 30 x 10 mm	1
2420950000	CMA-31-200-5A-5VA-1	200 A	5 A	1	5 VA	25.70 mm	20 x 20 mm, 25 x 12 mm, 30 x 10 mm	1
1482050000	CMA-31-250-5A-5VA-0,5	250 A	5 A	0,5	5 VA	25.70 mm	20 x 20 mm, 25 x 12 mm, 30 x 10 mm	1
2420940000	CMA-31-250-5A-5VA-1	250 A	5 A	1	5 VA	25.70 mm	20 x 20 mm, 25 x 12 mm, 30 x 10 mm	1
2420990000	CMA-31-300-5A-5VA-0,5	300 A	5 A	0,5	5 VA	25.70 mm	20 x 20 mm, 25 x 12 mm, 30 x 10 mm	1
2420980000	CMA-31-400-5A-5VA-0,5	400 A	5 A	0,5	5 VA	25.70 mm	20 x 20 mm, 25 x 12 mm, 30 x 10 mm	1
2420920000	CMA-31-400-5A-5VA-1	400 A	5 A	1	5 VA	25.70 mm	20 x 20 mm, 25 x 12 mm, 30 x 10 mm	1
1482070000	CMA-31-500-5A-5VA-0,5	500 A	5 A	0,5	5 VA	25.70 mm	20 x 20 mm, 25 x 12 mm, 30 x 10 mm	1
2420910000	CMA-31-500-5A-5VA-1	500 A	5 A	1	5 VA	25.70 mm	20 x 20 mm, 25 x 12 mm, 30 x 10 mm	1
2420970000	CMA-31-600-5A-5VA-0,5	600 A	5 A	0,5	5 VA	25.70 mm	20 x 20 mm, 25 x 12 mm, 30 x 10 mm	1
2420900000	CMA-31-600-5A-5VA-1	600 A	5 A	1	5 VA	25.70 mm	20 x 20 mm, 25 x 12 mm, 30 x 10 mm	1
1482080000	CMA-31-750-5A-5VA-0,5	750 A	5 A	0,5	5 VA	25.70 mm	20 x 20 mm, 25 x 12 mm, 30 x 10 mm	1
2420890000	CMA-31-750-5A-5VA-1	750 A	5 A	1	5 VA	25.70 mm	20 x 20 mm, 25 x 12 mm, 30 x 10 mm	1
Note	For additional articles and information, refer to catalog.weidmueller.com							

Plug-on current transformer

The CMA-1056 series current transformer can measure primary currents in the range of 800 A to 4000 A and convert them to a current of up to 5 A on the secondary side. The transformer is equipped with a maintenance-free spring balancer cage clamp and is especially suitable for installation on current bars and on cables of new systems.

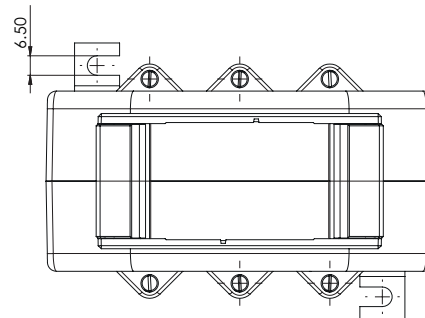
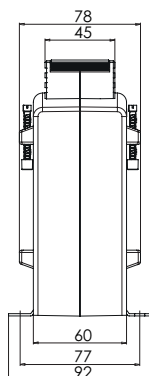
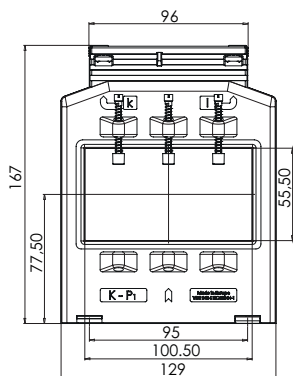

Ordering data

Order No.	Type	Primary current	Secondary current max.	Tolerance class	Load	Round conductor	Rail	Qty.
1516880000	CMA-1056-800-5A-10VA-1	800 A	5 A	1	10 VA	55.00 mm	100 x 55 mm	1
2420880000	CMA-1056-800-5A-5VA-0,5	800 A	5 A	0,5	5 VA	55.00 mm	100 x 55 mm	1
1516870000	CMA-1056-1000-5A-15VA-1	1000 A	5 A	1	15 VA	55.00 mm	100 x 55 mm	1
2420870000	CMA-1056-1000-5A-2,5VA5	1000 A	5 A	0,5	2.5 VA	55.00 mm	100 x 55 mm	1
1516850000	CMA-1056-1200-5A-15VA-1	1200 A	5 A	1	15 VA	55.00 mm	100 x 55 mm	1
2421390000	CMA-1056-1200-5A-5VA-05	1200 A	5 A	0,5	5 VA	55.00 mm	100 x 55 mm	1
2420810000	CMA-1056-1500-5A-10VA-1	1500 A	5 A	1	10 VA	55.00 mm	100 x 55 mm	1
2420860000	CMA-1056-1500-5A-5VA-05	1500 A	5 A	0,5	5 VA	55.00 mm	100 x 55 mm	1
1516820000	CMA-1056-1600-5A-30VA-1	1600 A	5 A	1	30 VA	55.00 mm	100 x 55 mm	1
2420850000	CMA-1056-1600-5A-5VA-05	1600 A	5 A	0,5	5 VA	55.00 mm	100 x 55 mm	1
2420800000	CMA-1056-2000-5A-30VA-1	2000 A	5 A	1	30 VA	55.00 mm	100 x 55 mm	1
2420840000	CMA-1056-2000-5A-5VA-05	2000 A	5 A	0,5	5 VA	55.00 mm	100 x 55 mm	1
2420790000	CMA-1056-2500-5A-30VA-1	2500 A	5 A	1	30 VA	55.00 mm	100 x 55 mm	1
2420830000	CMA-1056-2500-5A-5VA-05	2500 A	5 A	0,5	5 VA	55.00 mm	100 x 55 mm	1
2420820000	CMA-1056-3000-5A-5VA-05	3000 A	5 A	0,5	5 VA	55.00 mm	100 x 55 mm	1
1516840000	CMA-1056-4000-5A-30VA-1	4000 A	5 A	1	30 VA	55.00 mm	100 x 55 mm	1
Note	For additional articles and information, refer to catalog.weidmueller.com							

Rod current transformer

The CMA-CTM 7 series mini current transformer is an inductive current transformer designed according to the transformer principle for circular primary conductors. The CMA-CTM 7 series current transformers are maintenance-free and is designed for measuring primary currents in the range 32 A to 64 A. This is converted into a current up to 1 A on the secondary side. With its small dimensions, it perfectly suits applications in a 3-phase circuit breaker with a phase separation of 17.5 mm.

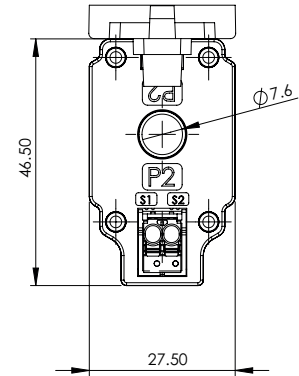
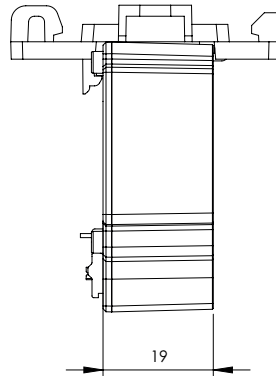
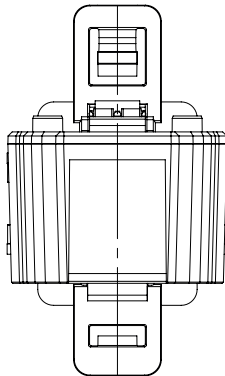

Ordering data

Order No.	Type	Primary current	Secondary current max.	Tolerance class	Load	Round conductor	Rail	Qty.
2525150000	CMA-CTM-7-32-1A-0.2VA-1	32 A	1 A	1	0.2 VA	7.60 mm	Rail	1
2486490000	CMA-CTM-7-35-1A-0.2VA-1	35 A	1 A	1	0.2 VA	7.60 mm	Rail	1
2556040000	CMA-CTM-7-40-1A-0.3VA-1	40 A	1 A	1	0.3 VA	7.60 mm	Rail	1
2556030000	CMA-CTM-7-50-1A-0.4VA-1	50 A	1 A	1	0.4 VA	7.60 mm	Rail	1
2556020000	CMA-CTM-7-60-1A-0.4VA-1	60 A	1 A	1	0.4 VA	7.60 mm	Rail	1
2556010000	CMA-CTM-7-64-1A-0.5VA-1	64 A	1 A	1	0.5 VA	7.60 mm	Rail	1

Note For additional articles and information, refer to catalog.weidmueller.com

Accessories

Order No.	Type	Qty.	Order No.	Type	Qty.
2525160000	CMA-CTM-7-SNAP-ON	1	2525160000	CMA-CTM-7-SNAP-ON	1

Note

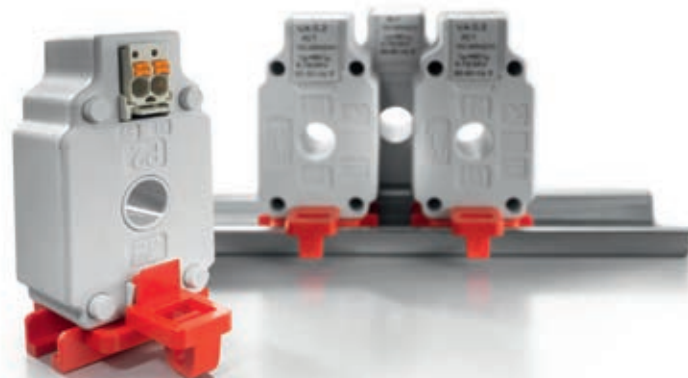

Rod current transformer

The CMA-22 series current transformers are for circular primary conductor. Current transformers from this series are maintenance-free and are designed for primary currents in the range of 50 A to 600 A which are converted into a current of up to 5 A on the secondary side.

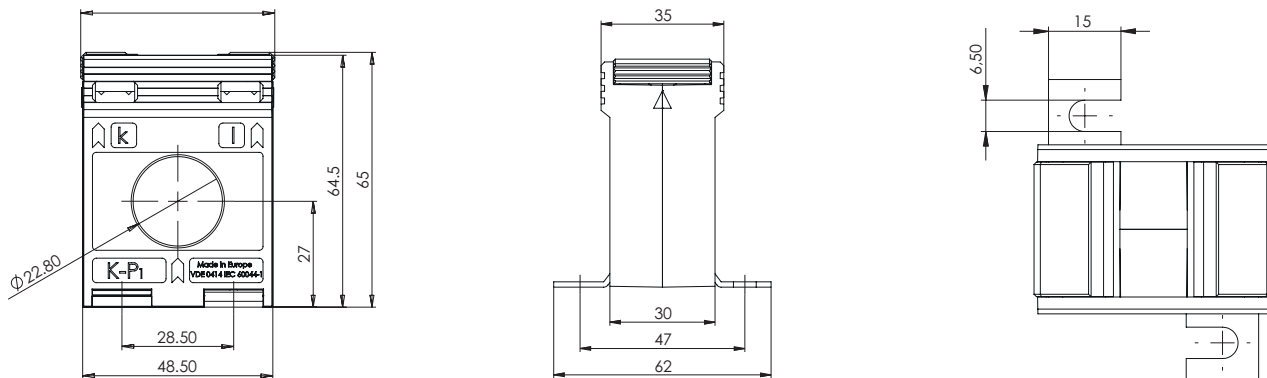

Ordering data

Order No.	Type	Primary current	Secondary current max.	Tolerance class	Load	Round conductor	Rail	Qty.
2421100000	CMA-22-50-5A-1VA-1	50 A	5 A	1	1 VA	22.50 mm		1
1482140000	CMA-22-60-5A-1,5VA-1	60 A	5 A	1	1.5 VA	22.50 mm		1
2421080000	CMA-22-75-5A-1,5VA-1	75 A	5 A	1	1.5 VA	22.50 mm		1
2421070000	CMA-22-100-5A-1,5VA-1	100 A	5 A	1	1.5 VA	22.50 mm		1
1482150000	CMA-22-100-5A-2,5VA-0,5	100 A	5 A	0,5	2.5 VA	22.50 mm		1
2421060000	CMA-22-150-5A-1,5VA-1	150 A	5 A	1	1.5 VA	22.50 mm		1
2421110000	CMA-22-200-5A-2,5VA-0,5	200 A	5 A	0,5	2.5 VA	22.50 mm		1
2421370000	CMA-22-200-5A-2,5VA-1	200 A	5 A	1	2.5 VA	22.50 mm		1
2461270000	CMA-22-200-5A-2,5VA-0,2	200 A	5 A	0,2	2.5 VA	22.50 mm		1
2461280000	CMA-22-250-5A-2,5VA-0,2	250 A	5 A	0,2	2.5 VA	22.50 mm		1
1482170000	CMA-22-250-5A-5VA-0,5	250 A	5 A	0,5	5 VA	22.50 mm		1
2421050000	CMA-22-250-5A-5VA-1	250 A	5 A	1	5 VA	22.50 mm		1
2461290000	CMA-22-300-5A-2,5VA-0,2	300 A	5 A	0,2	2.5 VA	22.50 mm		1
2421000000	CMA-22-300-5A-5VA-0,5	300 A	5 A	0,5	5 VA	22.50 mm		1
2421040000	CMA-22-300-5A-5VA-1	300 A	5 A	1	5 VA	22.50 mm		1
2461300000	CMA-22-400-5A-2,5VA-0,2	400 A	5 A	0,2	2.5 VA	22.50 mm		1
2421010000	CMA-22-400-5A-5VA-0,5	400 A	5 A	0,5	5 VA	22.50 mm		1
2461310000	CMA-22-500-5A-2,5VA-0,2	500 A	5 A	0,2	2.5 VA	22.50 mm		1
1482220000	CMA-22-500-5A-5VA-0,5	500 A	5 A	0,5	5 VA	22.50 mm		1
2461330000	CMA-22-600-5A-2,5VA-0,2	600 A	5 A	0,2	2.5 VA	22.50 mm		1
1482180000	CMA-22-600-5A-5VA-0,5	600 A	5 A	0,5	5 VA	22.50 mm		1

Note For additional articles and information, refer to catalog.weidmueller.com

Split-core current transformer

The KCMA-18 series cable-type current transformer is mainly used for refitting in existing systems. As a result of its compact design with dimensions of 41.6 x 64.5 x 67.3 mm, it is especially suited for installation in hard-to-reach places or for the use in locations with restricted dimensional freedom. The KCMA-18 measures primary currents in the range 50 A to 250 A and transforms these on the secondary side up to 1 A. When installing, the locking mechanism is opened, the transformer is positioned around the primary conductor and is then closed again with an audible click. Once the secondary cables are successfully connected, the measuring apparatus is immediately ready for operation.

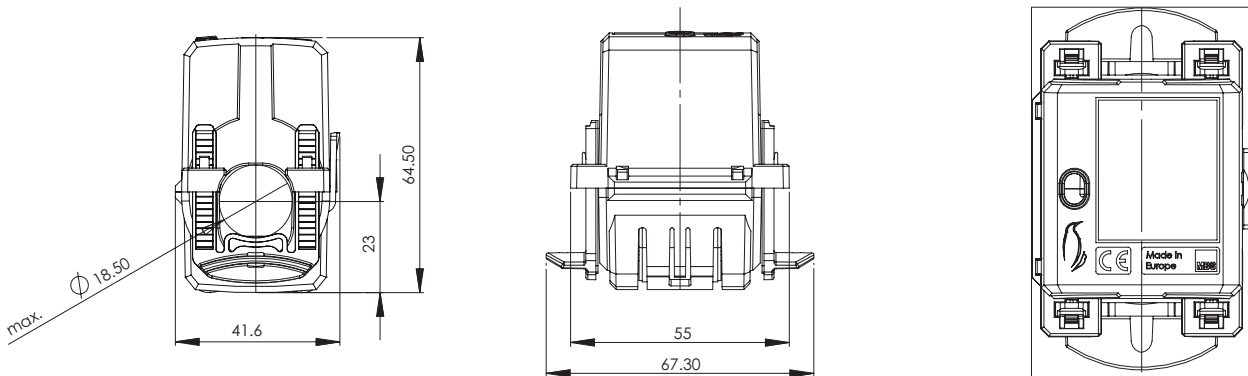

Ordering data

Order No.	Type	Primary current	Secondary current max.	Tolerance class	Load	Round conductor	Rail	Qty.
1482020000	KCMA-18-50-1A-1VA-3	50 A	1 A	3	1 VA	18.50 mm		1
2420780000	KCMA-18-75-1A-1VA-3	75 A	1 A	3	1 VA	18.50 mm		1
1482010000	KCMA-18-100-1A-1,25VA-3	100 A	1 A	3	1.25 VA	18.50 mm		1
2420770000	KCMA-18-150-1A-2VA-3	150 A	1 A	3	2 VA	18.50 mm		1
2420760000	KCMA-18-200-1A-3VA-3	200 A	1 A	3	3 VA	18.50 mm		1
1482000000	KCMA-18-250-1A-1,5VA-1	250 A	1 A	1	1.5 VA	18.50 mm		1
2420750000	KCMA-18-250-1A-4VA-3	250 A	1 A	3	4 VA	18.50 mm		1
Note	For additional articles and information, refer to catalog.weidmueller.com							

Cable-type current transformer

The KCMA-32 series cable-type current transformer is mainly used for retrofitting in existing systems. As a result of its compact design with dimensions of 59.2 x 96.4 x 89.2 mm, it is especially suited for installation in hard-to-reach places or for the use in locations with restricted dimensional freedom. The KCMA-32 measures primary currents in the range 400 A to 600 A and converts these on the secondary side up to 5 A. When installing, the locking mechanism is opened, the transformer is positioned around the primary conductor and is then closed again with an audible click. Once the secondary cables are successfully connected, the measuring apparatus is immediately ready for operation.

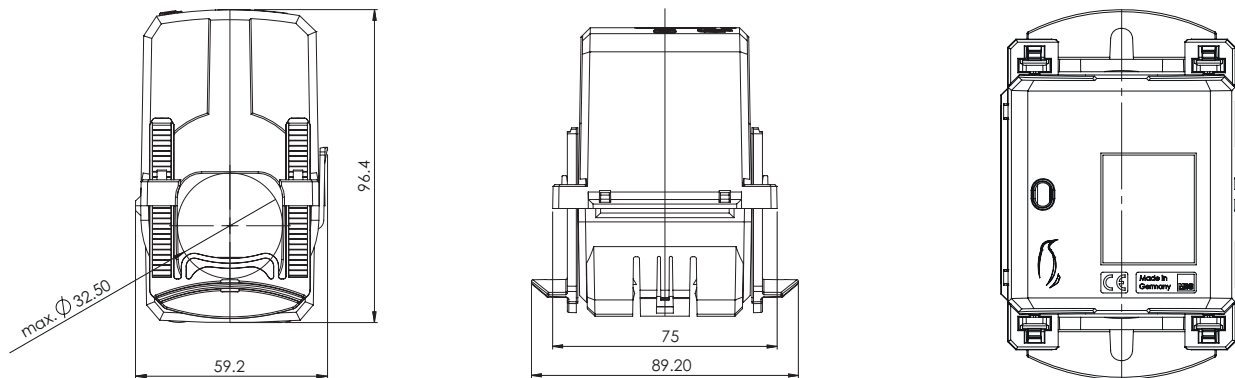

Ordering data

Order No.	Type	Primary current	Secondary current max.	Tolerance class	Load	Round conductor	Rail	Qty.
1481990000	KCMA-32-400-1A-5VA-1	400 A	1 A	1	5 VA	32.50 mm	Rail	1
2420730000	KCMA-32-400-5A-5VA-1	400 A	5 A	1	5 VA	32.50 mm	Rail	1
2420740000	KCMA-32-500-5A-5VA-1	500 A	5 A	1	5 VA	32.50 mm	Rail	1
1481980000	KCMA-32-600-1A-5VA-1	600 A	1 A	1	5 VA	32.50 mm	Rail	1
2420720000	KCMA-32-600-5A-5VA-1	600 A	5 A	1	5 VA	32.50 mm	Rail	1
Note	For additional articles and information, refer to catalog.weidmueller.com							

Cable-type current transformer

The KCMA-44 series cable-type current transformer is mainly used for retrofitting in existing systems. As a result of its compact design with dimensions of 72.2 x 120.6 x 98.1 mm, it is especially suited for installation in hard-to-reach places or for the use in locations with restricted dimensional freedom. The KCMA-44 measures primary currents in the range 750 A to 1000 A and transforms these on the secondary side up to 5 A. When installing, the locking mechanism is opened, the transformer is positioned around the primary conductor and is then closed again with an audible click. Once the secondary cables are successfully connected, the measuring apparatus is immediately ready for operation.

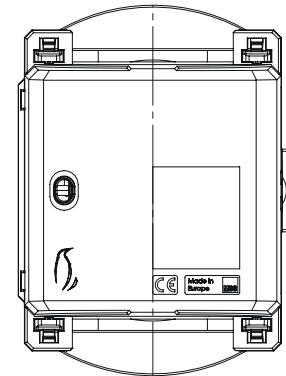
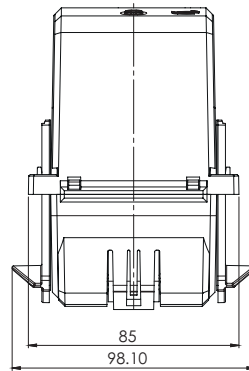
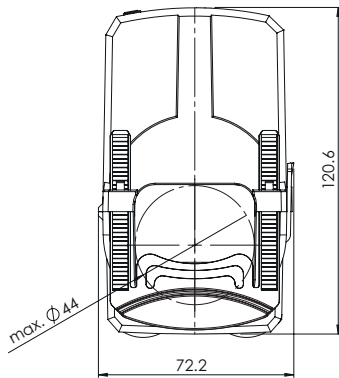

Ordering data

Order No.	Type	Primary current	Secondary current max.	Tolerance class	Load	Round conductor	Rail	Qty.
2420710000	KCMA-44-750-5A-5VA-1	750 A	5 A	1	5 VA	44.00 mm		1
2437370000	KCMA-44-800-5A-5VA-1	800 A	5 A	1	5 VA	44.00 mm		1
2437400000	KCMA-44-1000-5A-5VA-1	1000 A	5 A	1	5 VA	44.00 mm		1
Note	For additional articles and information, refer to catalog.weidmueller.com							

Cable-type current transformer

The CMA-812 series cable-type current transformer with its separable measuring core allows it to be fitted in existing systems without interrupting the primary conductor. Thanks to the practical integrated interlock system, the transformer can be positioned around the primary conductor and is then closed again with an audible click. The CMA-812 measures primary currents in the range of 600 A to 1500 A and transforms it currents of up to 5 A on the secondary side.

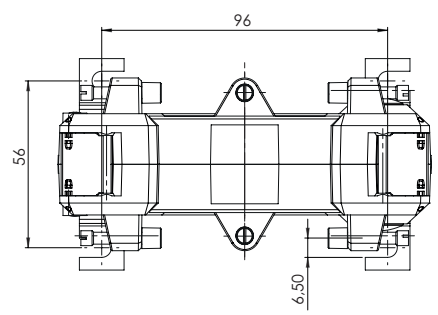
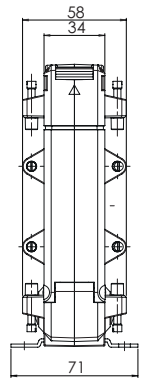
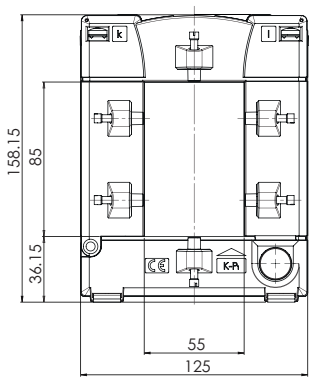

Ordering data

Order No.	Type	Primary current	Secondary current max.	Tolerance class	Load	Round conductor	Rail	Qty.
2464820000	CMA-812-600-1A-2.5VA-05	600 A	1 A	0,5	2.5 VA	80.00 mm	80 x 120 mm	1
2438470000	CMA-812-15-5A-15VA-1	1500 A	5 A	1	15 VA	80.00 mm	80 x 120 mm	1
2438480000	CMA-812-15-5A-7.5VA-0.5	1500 A	5 A	0,5	7.5 VA	80.00 mm	80 x 120 mm	1
Note	For additional articles and information, refer to catalog.weidmuller.com							

Current Transformers

Cable-type current transformer

The CMA-58 series cable-type current transformer with its separable measuring core allows it to be retrofitted in existing systems without interrupting the primary conductor. Thanks to the practical integrated interlock system, the transformer can be positioned around the primary conductor and is then closed again with an audible click. Here the CMA-58 measures primary currents up to 600 A and transforms them to currents up to 5 A on the secondary side.

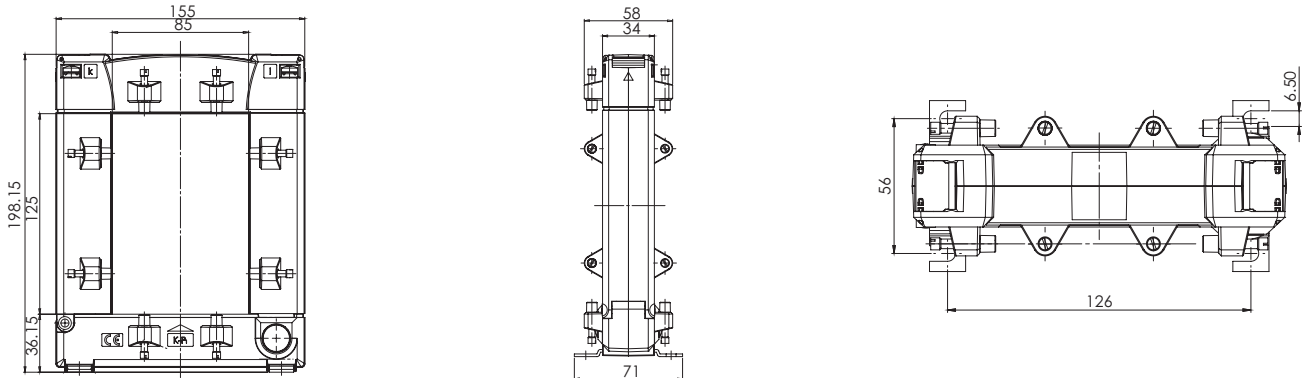

Ordering data

Order No.	Type	Primary current	Secondary current max.	Tolerance class	Load	Round conductor	Rail	Qty.
2464810000	CMA-58-600-1A-2.5VA-0.5	600 A	1 A	0,5	2.5 VA	50.00 mm	50 x 80 mm	1
Note	For additional articles and information, refer to catalog.weidmueller.com							

Wire-wrap current transformer

Because the accuracy and performance of current transformers at lower rated currents is low or would require a more expensive core, the WSK-30 series winding current transformers are particularly suitable if primary currents in the range 5 A to 20 A are to be measured. These are converted into a rated current of up to 5 A on the secondary side.

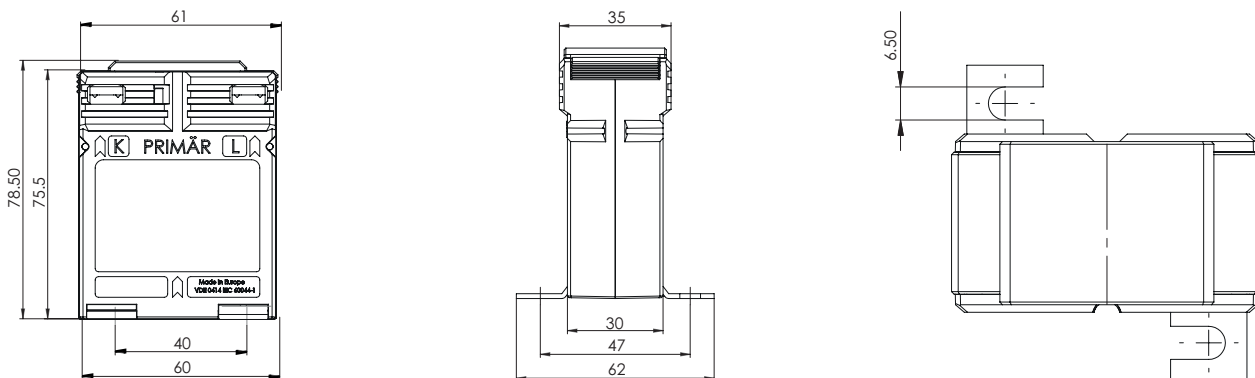

Ordering data

Order No.	Type	Primary current	Secondary current max.	Tolerance class	Load	Round conductor	Rail	Qty.
2556050000	WSK-30-5-5A-2.5VA-1	5 A	5 A	1	2.5 VA			1
2556060000	WSK-30-10-5A-2.5VA-1	10 A	5 A	1	2.5 VA			1
2556070000	WSK-30-15-5A-2.5VA-1	15 A	5 A	1	2.5 VA			1
2556080000	WSK-30-20-5A-2.5VA-1	20 A	5 A	1	2.5 VA			1
Note	For additional articles and information, refer to catalog.weidmuller.com							

Three-phase current transformer

The CMA-205 series three-phase current transformers unify all the advantages of rod current transformers in one module - for cost-effective and space-saving installation directly at the switch outputs. Current transformers from this series measure primary currents in the range 100 A to 250 A and convert them up to 5 A on the secondary side.

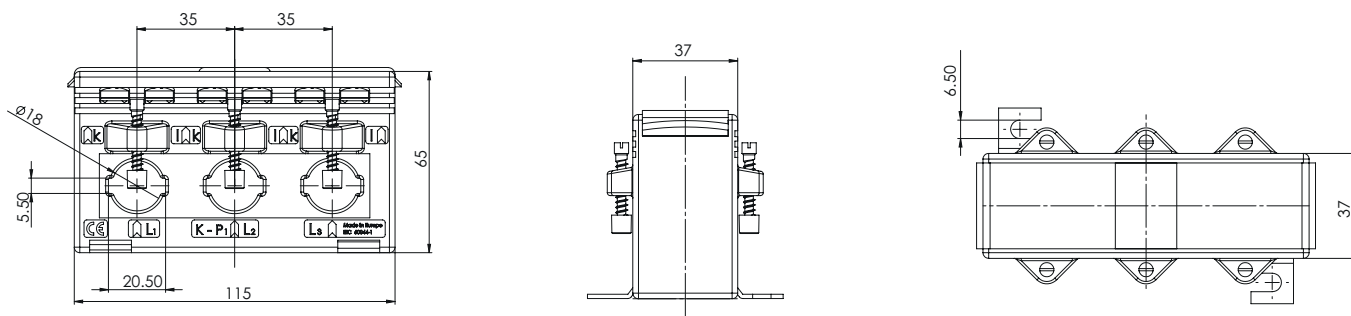

Ordering data

Order No.	Type	Primary current	Secondary current max.	Tolerance class	Load	Round conductor	Rail	Qty.
2420700000	CMA-205-100-5A-1VA-1	100 A	5 A	1	1 VA	18.00 mm	20 x 5 mm	1
2420690000	CMA-205-150-5A-1,25VA-1	150 A	5 A	1	1.25 VA	18.00 mm	20 x 5 mm	1
2420680000	CMA-205-200-5A-1,5VA-1	200 A	5 A	1	1.5 VA	18.00 mm	20 x 5 mm	1
2420670000	CMA-205-250-5A-2,5VA-1	250 A	5 A	1	2.5 VA	18.00 mm	20 x 5 mm	1
Note	For additional articles and information, refer to catalog.weidmueller.com							

Three-phase current transformer

The CMA-310 series three-phase current transformers unify all the advantages of rod current transformers in one module - for cost-effective and space-saving installation directly at the switch outputs. Current transformers from this series measure primary currents in the range 300 A to 600 A and convert them up to 5 A on the secondary side.

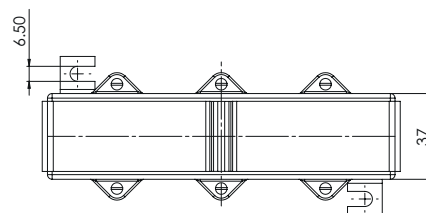
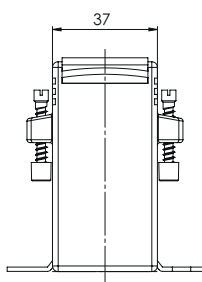
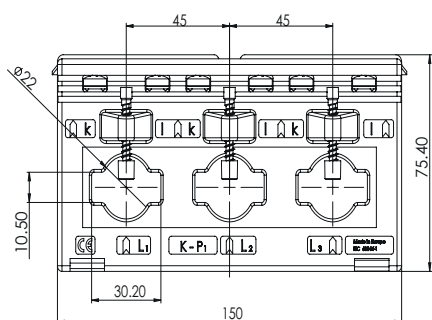

Ordering data

Order No.	Type	Primary current	Secondary current max.	Tolerance class	Load	Round conductor	Rail	Qty.
2420660000	CMA-310-300-5A-3,75VA-1	300 A	5 A	1	3.75 VA	22.00 mm	30 x 10 mm	1
2420650000	CMA-310-400-5A-5VA-1	400 A	5 A	1	5 VA	22.00 mm	30 x 10 mm	1
2420610000	CMA-310-500-5A-5VA-1	500 A	5 A	1	5 VA	22.00 mm	30 x 10 mm	1
2420600000	CMA-310-600-5A-5VA-1	600 A	5 A	1	5 VA	22.00 mm	30 x 10 mm	1
Note	For additional articles and information, refer to catalog.weidmueller.com							

Measure energy consumption simply, safely and flexibly

Rogowski current transformers for easy retrofitting

To comply with growing environmental demands, companies must provide transparency about the energy consumption of their machines and plants. Rogowski coils reliably measure alternating current and integrate quickly and easily into existing environments.

Our Rogowski coils can be, optionally, integrated on busbars or with power cables. Three sizes are available to fit diameters between 70 and 175 mm. The output signal of a coil feeds to a transmitter, which detects alternating currents or a voltage signal. One of two models has a standard output signal (1 A), while the other allows to adjust the output signal to four different V or mA ranges. The input measuring range can be selected from twelve values between 100 and 5000 A.



Your special advantages

- Very high accuracy of coil and transmitter according to class 0.5
- No calibration required
- Compact plastic housing

Technical data

Rogowski coils	Diameter	Cable length	Primary current	Order No.	Qty.
RCMA-B22-D70-4.5	70 mm	4.5 m	5.000 A	2593340000	1
RCMA-B22-D70-1.5	70 mm	1.5 m	5.000 A	2593370000	1
RCMA-B22-D125-1.5	125 mm	1.5 m	5.000 A	2593380000	1
RCMA-B22-D125-4.5	125 mm	4.5 m	5.000 A	2593350000	1
RCMA-B22-D175-1.5	175 mm	1.5 m	5.000 A	2593390000	1
RCMA-B22-D175-4.5	175 mm	4.5 m	5.000 A	2593360000	1
Transmitter	Output	Measurement range	Order No.	Qty.	
RCMC-5000-1A-P	1 A	Our standard products are offered in 12 different variants, from 100 A up to 5000 A:	2593400000	1	
RCMC-5000-A0-P	0 - 20 mA, 4 - 20 mA, 0 - 5 V, 0 - 10 V		2593410000	1	

Efficient implementation of testing and measurement switchgear

Current and voltage transformer wiring solutions

When installing power monitoring components, a simple defective connection can result in the destruction of current transformers or voltage converters. Our specially developed test-disconnect terminal blocks are a safe way of solving this problem. Easy to use and available with different connection technologies, they facilitate error-free and convenient wiring. This guarantees the protection of your transformers and measuring devices and ensures safe, precise work. The modular concept of our terminal blocks for transformer switchgears also saves space in the cabinet.

Avoiding errors through ease of use

Our test terminal blocks with tried-and-tested screw connection technology allow a large number of switching tasks to be overcome clearly and cost-effectively. The screws for the wire connection can only be accessed once the current transformer's short-circuit slider has been activated. This enhances safety as it prevents the accidental short-circuiting or opening of the converter circuit. Our pre-installed LST EM-BLOCK makes it easier to connect and short the current transformers, and is suitable for up to four phases.

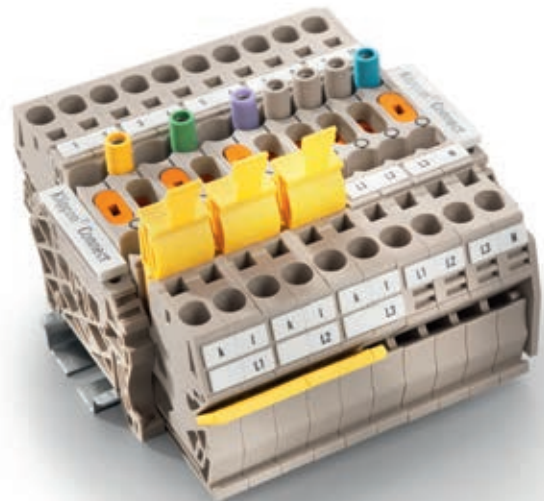

Ordering data

Type	Order No.
LST EM-BLOCK	8000028895

Technical data

Connectable current transformers	4
Fuses for measurement voltage	3 phases
Fuse for supply voltage	Yes
Neutral conductor connection	2
PE connection	Yes
Markers	Yes

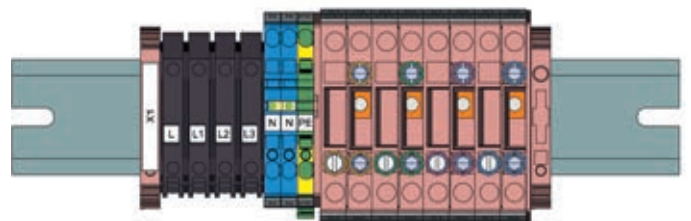

Convenient retrofitting of Energy Management systems

EM-Connectivity-Box, the flexible solution

The responsible handling of energy and resources is becoming increasingly important for many companies. This requires a transparent display of all energy consumption. The EM-Connectivity-Box from Weidmüller is a solution for optimum energy transparency without having to invest in new machinery.

The EM-Connectivity-Box is a flexible complete solution for the introduction or extension of an energy management system. The separate enclosure means no additional space is required in the cabinet.

This means you can easily include both existing and new systems into your Energy Management system. The solution is impressive in its modularity and can be combined with a range of standard measuring instruments and systems.

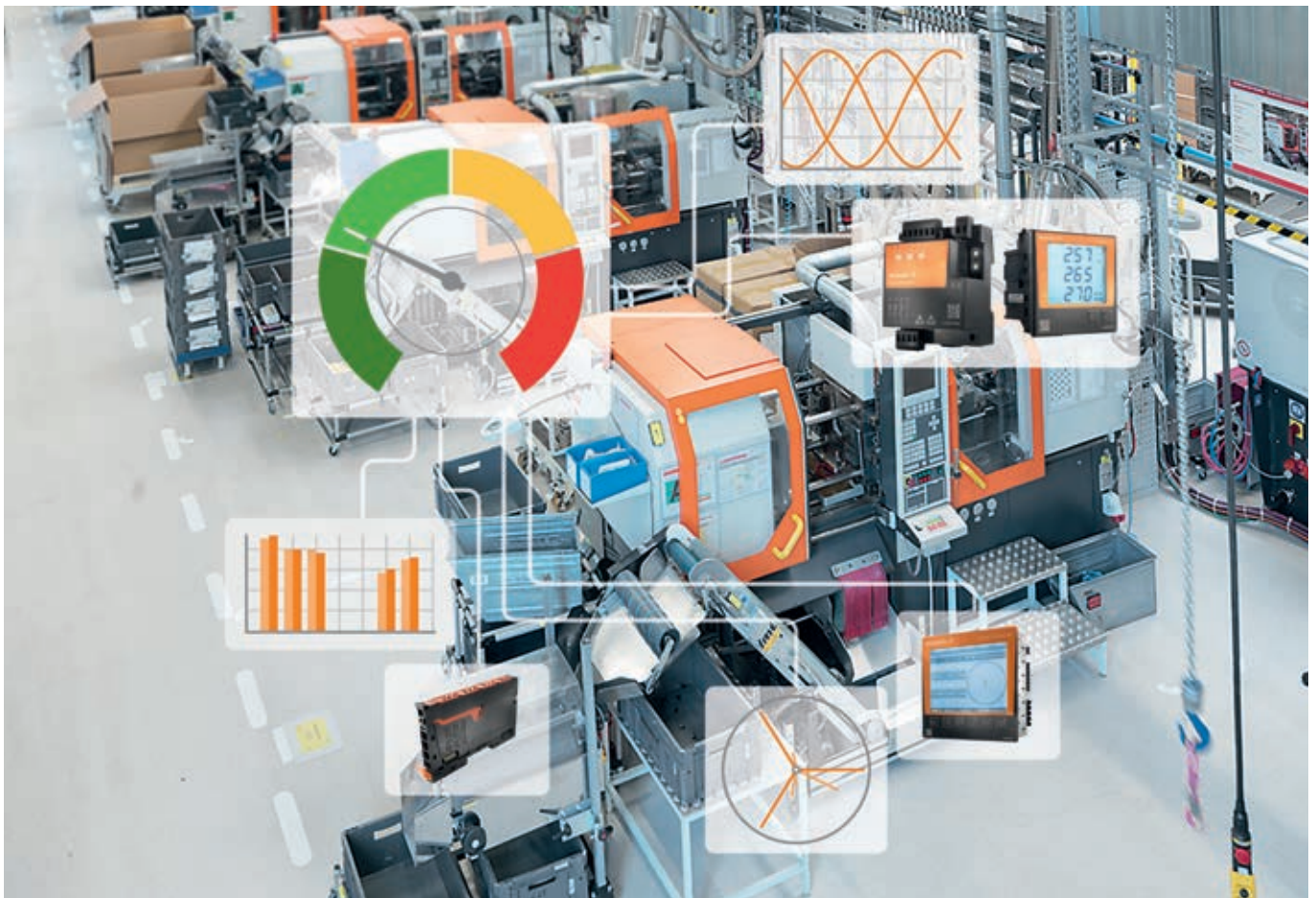

Excellent efficiency in one enclosure

The EM-Connectivity-Box in detail

Our EM-Connectivity-Box is a perfect combination of established products from the Weidmüller range.

You can choose between aluminium and plastic enclosures to meet your requirements. The enclosures are milled to fit and are equipped with the requisite cable bushings. A modular terminal block to suit the measuring instruments to be fitted is already installed inside. There is also a labelled cable set which is specially adapted to the measuring equipment in question.

The benefits at a glance

- Quicker and cheaper installation
- No significant changes required in the control cabinet or power distribution
- All the fuses, short-circuit devices, labelled cables and circuit diagrams are included
- No engineering required
- Protection class up to IP65 (EM-Connectivity-Box TS)
- Can be ordered as a standard item
- No minimum order



Our solution contains

- High-quality Weidmüller enclosure complete with cable bushings
- Measurement converter, disconnecter terminals, modular terminal blocks and fuse terminals
- Complete cable set, assembled and labelled, including Ethernet cable
- Supplied without measuring instrument and current transformer (available separately)

Ordering data



Type	Type of protection	Dimensions (h x w x d)	Material	Order No.
EM-Connectivity-Box 96	IP54	310 x 230 x 111 mm	Aluminium	8000028950



EM-Connectivity-Box TS	IP65	310 x 230 x 111 mm	Aluminium	8000028951
------------------------	------	--------------------	-----------	------------

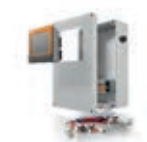

EM-Connectivity-Box 144	IP42	430 x 250 x 120 mm	Plastic	8000028952
-------------------------	------	--------------------	---------	------------

Implement energy measurements simply and effectively

Maximum energy transparency for minimum cost

The EM-Connectivity-Box from Weidmüller has the perfect properties to allow really effective introduction or extension of an Energy Management system. As well as the option of flexible selection of the measuring instrument, there is also perfect coordination between all associated products, especially the enclosure and connection terminals.



Flexible choice of measuring instrument

Three different designs enable a good choice from our energy measuring instruments to suit your specific needs.



High quality, assembled enclosure

Our energy measuring instruments are made from high-quality aluminium and plastic enclosures which already have all the necessary drilled holes and cut-outs.





Components marked to prevent mix-ups

All cables, terminals and connections on the measuring instrument are clearly labelled in the factory to ensure quick, correct connections.



Tried and tested Weidmüller modular terminal blocks

To enable optimum connection to our energy measuring instruments, we have specially selected a range of our tried and tested modular terminal blocks.



Easy to install current transformers

Our cable conversion current transformers are easy to fit without disconnecting the cable. Alternatively, we offer a wide range of through and clip-on current transformers.



Gigabit Industrial Security Router

Secure data communication with integrated VPN technology

You want to be able to communicate with your machinery and systems securely, reliably, and from anywhere? Should only verified data gain access to your industrial network? Then the new Industrial Security Router from Weidmüller is just the right choice.

Due to the steady increase in networking data and information in office-based communication, a strong trend has evolved where the advantages of Ethernet communication are progressively being used in the area of industrial automation technology.

As well as the standardisation provided by Ethernet technology, vertical data integration from the field/production level across the office network to the Internet is an important driver for its rapid spread in industrial applications.

In addition to LAN switching technologies, we are seeing increased use of industrial routers for enhanced security and for efficient management of data traffic between LANs.

Routers with integrated VPN technologies are also ideally suited to secure remote access to components and systems in the LAN, via either a wired or wireless Internet connection.

Technical features of Weidmüller routers at a glance

- Compact and robust industrial-grade metal housing (aluminium die casting)
- Gigabit Ethernet interfaces (LAN/WAN) for high data throughput
- Digital inputs/outputs (24 V DC) with functions for disconnecting WAN port, indicating alarm status, starting/stopping of pre-configured VPN connections and indicating active VPN tunnel
- Supports all standard router functions such as static/dynamic routing, SNMP, DHCP server, Dynamic DNS, event logging or DSL connection (PPPoE) via external DSL modem
- Flexibly configurable stateful inspection firewall with filter functions for both Layer 3 (IP layer) and Layer 2 (MAC address level)
- Extensive configuration options for IP address mapping (1:1 NAT, virtual mapping/NAT masquerading/port-forwarding/IP address forwarding), e.g. for connecting multiple machine networks in the same IP address range into a primary production network
- Integrated VPN functionality (OpenVPN and IPSec) for secure remote access over the Internet. The router can be used with both VPN technologies, either as a VPN client or a VPN server.
- Variable bandwidth management by prioritising and limiting network traffic to IP and Ethernet protocol level
- Variable user management through multiple user profiles with detailed assignment of rights
- Integrated Modbus/TCP server for controlling and querying the status of the digital inputs and outputs and pre-configured VPN connections with Modbus/TCP-capable devices (e.g. PLC)
- Client Monitoring for the monitoring of network devices
- "Remote Capture" function for monitoring network traffic via Wireshark (Network protocol analyser software)



You can find our entire network transformer technology portfolio in our online catalogue

Software

Software	Energy Suite	B.2
	ecoExplorer go	B.4
	u-create ResMa	B.6
	u-create data hub	B.8
	u-create energetics	B.10
	u-link	B.12

Data processing for Energy Management and energy analytics

Weidmüller Energy Suite

B

Data processing is becoming increasingly important in an industrial context. We are your partner for all matters relating to software application matters, and will provide you with suitable software solutions as necessary. With our comprehensive expertise, we ensure a smooth interplay in digitalised industry – from the recording of data at the field level and distribution using our industrial ethernet components through to comprehensive data processing in the fields of industrial analytics and Energy Management.



Industrial software solutions need to have a large number of specific properties in order to provide the greatest possible benefit. We will advise you on the selection and application of your software with our broad expertise. The focus for us is on the following factors:

Availability

Our high standards of quality guarantee error-free data processing, a high level of availability and long-term benefit.

Security

With all of our projects for customers we tackle the growing danger of attacks from hackers with a particularly thought-out approach. In this way we ensure the greatest possible security before, during and after implementation.

Data storage

Our software solutions allow you to reliably store data within your own network without needing to rely on cloud-based services.

Scalability

The scalability of our software solutions makes it possible to adapt the growing demands of your company at any time.

User-friendliness

Well thought-out and practical operation in the field plays a particularly important role for us. We focus on operating concepts that are tailored precisely to the location of use, and promote efficiency and productivity.



Conveniently record and clearly display measurement data

ecoExplorer go simplifies parameterisation and visualisation

B



Quick commissioning

The user-friendly interface of ecoExplorer go allows quick connection and configuration of the measurement devices.

Quick insight

For an efficient energy management, the further processing and evaluation of energy and measurement data for the power quality is of key importance. ecoExplorer go enables initial analysis of the energy grid.

Hardware-Requirements

- CPU: x86_64 Dualcore, $\geq 2,0$ GHz, ≥ 8 MB cache
- Min. 8 GB Memory
- Min. 16 GB free hard drive space (demand depends on data retention)

Operating system requirements

- Microsoft Windows 7, Microsoft Windows 8, Microsoft Windows 10
- Microsoft Windows Server 2008, Microsoft Windows Server 2012
- Microsoft Windows Server 2016

Data retention

- Local backup of the field device configuration
- Graphical configuration of Energy Meters / Energy Analysers
- Management of the field device memory (when available)

Field device-Configuration

- Local backup of the field device configuration
- Graphical configuration of Energy Meters / Energy Analysers
- Management of the field device memory (when available)

We reserve the right to make technical changes.

The visualisation of energy consumers is a central principle to make production sites more efficient.

Many of our energy measurement devices have a very simple user interface for reasons of clarity to allow the display and parameterisation of the measured data directly on the device. ecoExplorer go is a PC-based software which allows you to access your devices quicker and more simply and conveniently than before. Thanks to the intuitive user interface, users can configure the measurement devices quickly and easily and display the measured data clearly.

ecoExplorer go has been tailored to the use of measurement equipment in the energy sector. This guarantees that it provides optimum performance in practice.

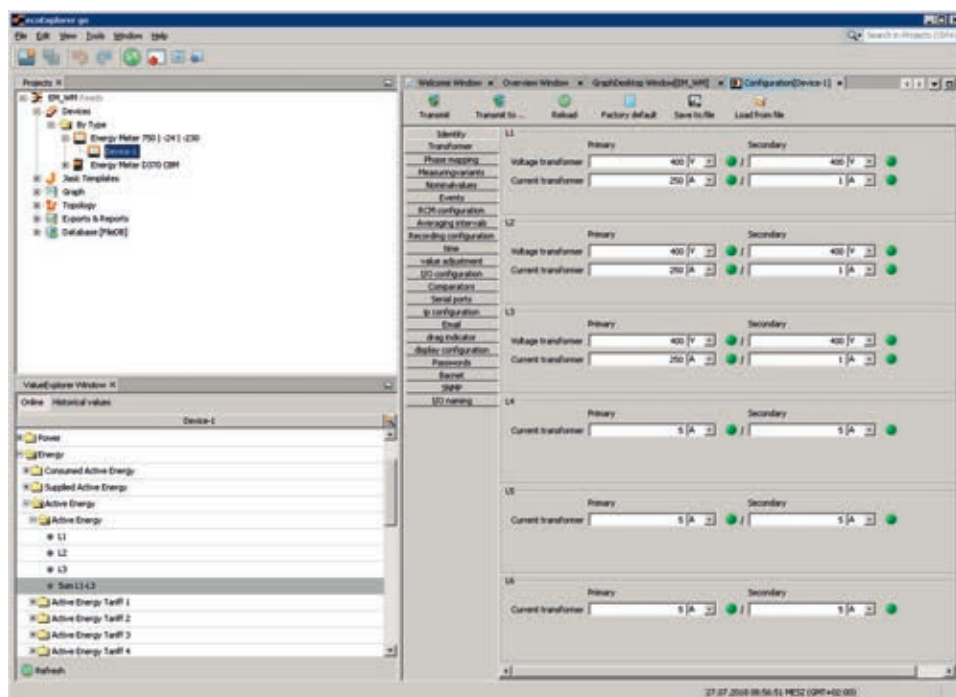

Continuous recording and monitoring of energy flows

Energy controlling and efficiency analysis with u-create ResMa

B

Use u-create ResMa as your universal tool for recording and monitoring of energy flows. u-create ResMa is not only a comprehensive software solution for energy management, but also integrates with existing automation technology, control technology and building automation.

Energy management according to ISO 50001 means the continuous review and optimization of energy efficiency. This everlasting task requires a maximum support by a powerful system that is able to do the monitoring and analysis largely independently. The generation of meaningful key performance indicators (KPIs), including also production parameters and their monitoring by field devices, is the basis for a reduction of the daily monitoring expenses.





u-create ResMa Compact

Cost-effective entry-level solution, preinstalled on a compact industrial PC for mounting in the control cabinet on a DIN rail. Direct connection of metering devices via Modbus RTU (RS485) or Modbus TCP. Unlimited evaluation options and reporting functionality.

u-create ResMa Server

Scalable solution for the installation on a dedicated or virtual server. No limitation of the functional scope and extensive options for the integration of third-party systems. PlugIn concept for customer extensions.

u-create ResMa Cloud

Use u-create ResMa on a rental basis as a cloud solution. Fast start of an own, also cross-location energy management without the need to setup a separate infrastructure. Scalable and crediting of the rental price on a purchase license.

Hardware-Requirements

- CPU: Core i7 Quadcore, 4x6 MB cache, 2 GHz
- Min. 8 GB Memory
- 256 GB server SSD / HDD 7.200 RPM Raid 1 setup

Operating system requirements

- Windows Server 2016
- Windows Server 2012
- Windows 7
- Windows 10

Network requirements

- Virtual network for field devices recommended.
- Installation by remote access (Weidmüller u-link, TeamViewer, VPN)
- Admin rights required for installation

Interfaces

- Modbus RTU, Modbus TCP, u-control, CoDeSys- and Beckhoff PLCs

We reserve the right to make technical changes.

Consistency of data for the digital factory

Universal data processing with the u-create data hub

B

Optimisation requires insight into production processes. The u-create data hub makes it possible to analyse, store and visualise your data from the field, and offers an efficient gateway to the recording and processing of data.

Vertical integration made easy

The u-create data hub is based on open source technology, which has proven its worth many times over. The software solution includes a number of programming modules that can be used to establish protocol connections, define functions and trigger events on the basis of incoming data.

With the Weidmüller u-mation toolbox you receive preconfigured programming modules that allow you to set up a productive data processing system within a short space of time. You can use common protocols to incorporate your existing data sources, and start processing data using existing IT infrastructure without taking any financial risks.

A professional database system works in the background to quickly and reliably secure your data. Recording your data is convenient using drag & drop and graphical programming. You can convert recorded data to an MS Excel compatible format for further processing, or save it directly to the cloud. You can also program a data pre-processing system yourself, or have warning messages sent to you by e-mail.

Software-Module



Deployment technology

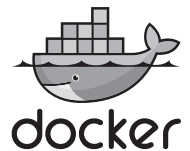

Deployment options

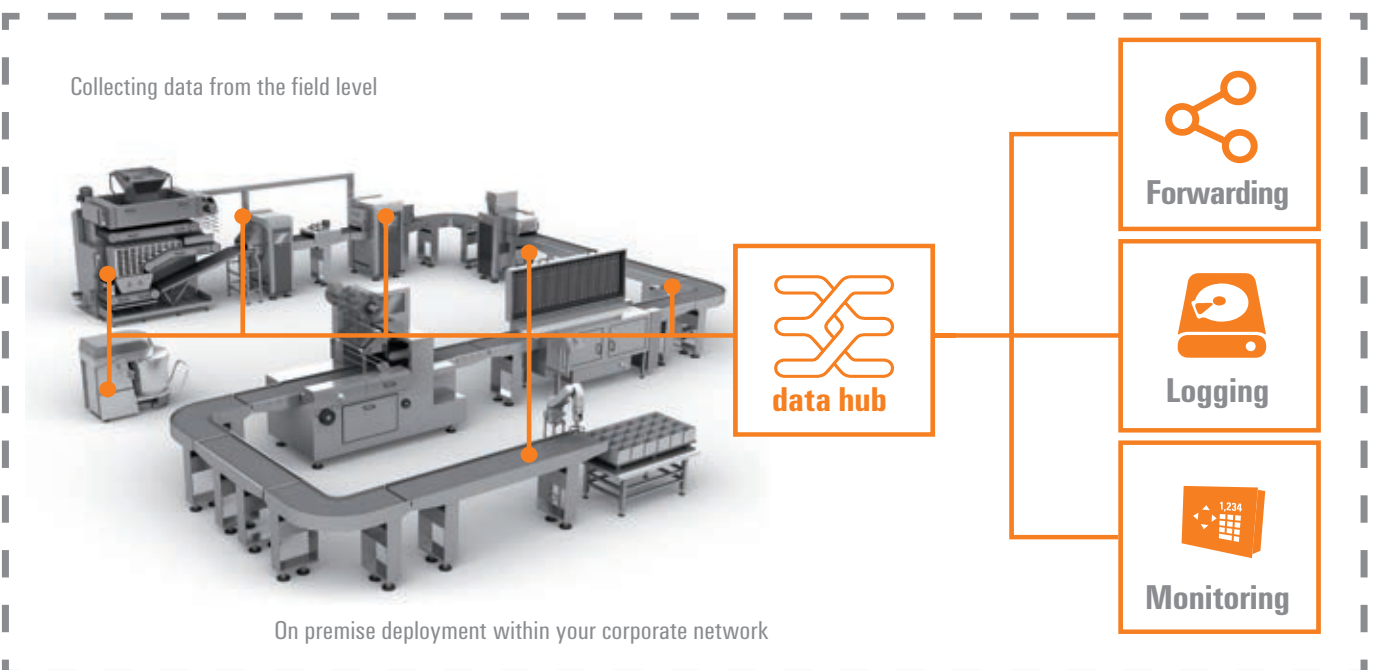

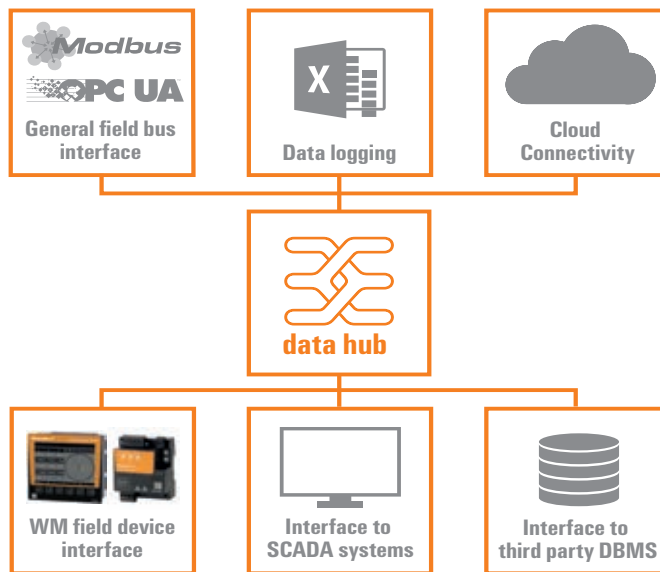

Use the u-create data hub as your universal data processing tool.

Take advantage of the open architecture, transparent interfaces and flexible possibilities for integration. The SQL-compatible database supplied with it allows the high-resolution recording and storage of a large volume of measurements. Simple installation and a short time to get up-and-running ensures uncomplicated integration into existing processes in order to derive and effectively exploit potential for improvement.

The u-create data hub is the right solution for data-driven applications. When combined with Weidmüller energy measuring instruments and the u-mation automation toolbox, it is simple and cost-effective to get started.

In order to make installation easier and facilitate a rapid start in the world of Industry 4.0, delivery takes the form of a preconfigured Docker container. The resulting versatility with respect to platforms means that the solution can be used in almost any IT environment.

Hardware-Requirements

- CPU: Dualcore, >= 2,5 GHz, x86_64 Intel VT-x / AMD-V instruction set, >= 8 MB cache
- Min. 4 GB Memory
- Min. 5 GB free hard drive space (demand depends on data retention)

Operating system requirements

- Docker Engine required.
- Windows: Hyper-V required; Windows Server 2016 Essentials, Windows 10 Pro
- Linux-Systems with kernel >= V.3.10

Data retention

- Logging of numerous values into a pre-configured database
- Data export to excel compatible format

Interfaces

- MQTT, E-Mail, Modbus TCP/RTU, OPC UA, FTP, weatherstation data (general.), IBM Watson, AWS IoT, several databases

We reserve the right to make technical changes.

Reliable projection of load profiles

Reducing peak loads with u-create energetics

B

In addition to the basic price, energy providers also charge for the peak supply that is to be provided. This makes it important for industrial companies to reduce their peak loads. u-create energetics allows you to reliably predict peak loads with relevance for billing purposes. This means that you can implement corresponding measures in good time, taking your production requirements into account. The free programming makes it possible to develop and introduce complex processes. The u-mation automation toolbox includes suitable solutions for the interaction between suppliers and consumers.

Why reduce peak loads?

If you use 100,000 kWh or more from the electricity grid each year, peak loads become relevant for the calculation of grid fees. This can mean that the highest 15-minute average output for a year is charged at €80 – 200 per kW, depending on the charging region and the level of voltage. Unfavourable usage patterns on the part of consumers can have a very negative impact on the calculation of grid fees.

Reliable projection

u-create energetics allows you to project peak loads up to two billing periods in advance. A feasibility study is first carried out using historical data in order to identify the quality of the anticipated projection. u-create energetics links to the u-create data hub during real operations. The data logging solution's central database then provides the data to calculate the projection. The projected load profile is then visualised using a web-based solution.

The entire u-create energetics system is installed and the end consumer's disconnectable loads are identified as part of a client project. The preliminary feasibility study (proof of concept) provides an initial indication of the potential savings, and does not result in an obligation to install the entire system.

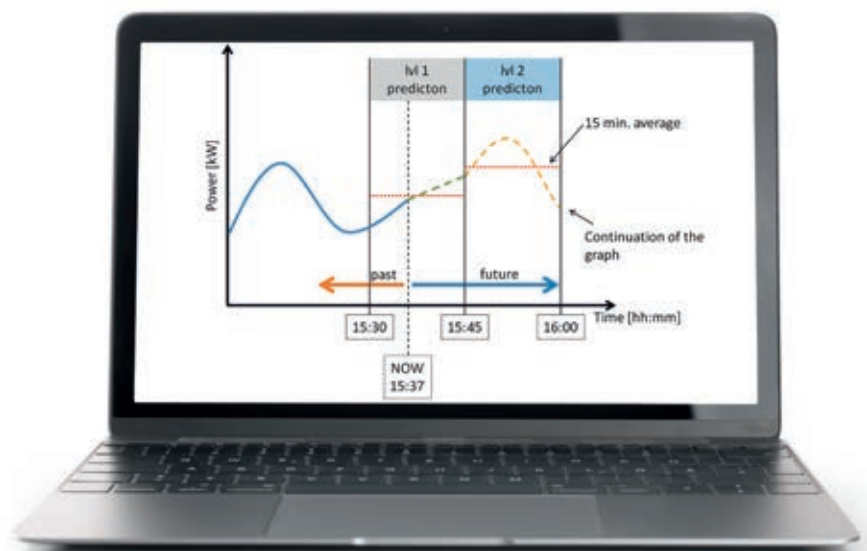

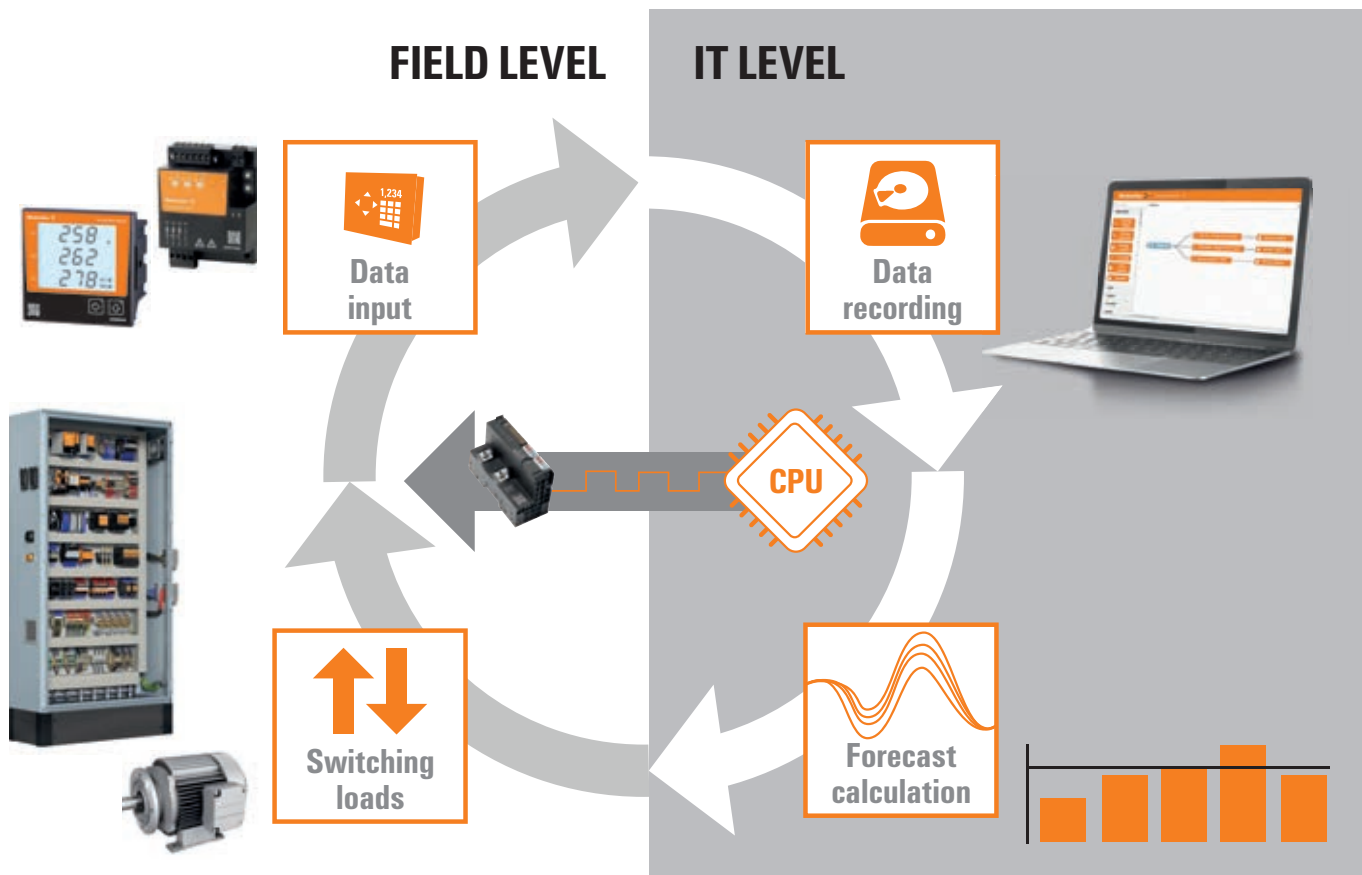

Hardware-Requirements

- CPU: Quadcore, >= 2,5 GHz, x86_64 Intel VTx / AMD-V instruction set, >= 12 MB cache
- Min. 16 GB Memory
- 256 GB server SSD

Operating system requirements

- Docker Engine required
- Windows: Hyper-V required; Windows Server 2016 Essentials, Windows 10 Pro
- Linux-Systems with kernel >= V.3.10

Deployment

- u-create energetics and u-create data hub can be executed on the same machine, but they don't have to.

Security

- Encrypted interface between u-create energetics and u-create data hub

We reserve the right to make technical changes.

Secure, remote access to your systems around the world

u-link Remote Access Service

B

u-link Remote Access Service

Accessing machinery and systems remotely has usually been complex and time-consuming in the past. It also places significant demands on the security of the IT systems and functions that are to be connected. For many users, these two issues make the connection of plants around the world a major obstacle. For many users, these two issues make the connection of plants around the world a major obstacle.

u-link guarantees quick and secure access to machines and systems, which makes remote access easier while also allowing for the efficient management of production plants and user clients. The intuitive u-link interface can be configured quickly and easily, and adjusted in line with internal processes. The innovative service also provides access to an online platform that ensures the compliance of

the various different IT systems for remote maintenance. Thanks to its special properties, u-link is a great basis for the secure and affordable assembly even of comprehensive remote access topologies. The clear structure means that multiple production systems and users are easy to manage, and the option of expansion to include limitless numbers of additional routers and users means that u-link can be optimally adapted to meet your company's specific requirements.

Easier plant access with security

u-link is the perfect remote maintenance solution for machine construction companies and plant operators. You can maintain a very productive any in-depth IT expertise. Quick, secure and simple.



www.u-link.weidmueller.com



Customised system management

u-link can be used to manage users, groups and their access rights based on individual requirements, such as a group assignment or access rights for production plants.



Reduced configuration effort

Thanks to the intuitive interfaces, routers and clients can easily be connected without the need for any in-depth IT expertise, which allows for the quick linking of multiple machines to the cloud service.



Secure remote maintenance and remote diagnostics

Machines and plants can be accessed remotely via a secure VPN connection, regardless of where they are in the world. The high level of availability of the servers means that you have secure access to your production facilities at all times.



Status monitoring and status reports

With Weidmüller Heartbeat, router availability can be reported to u-link, allowing for status monitoring and reporting of the installed router.

Service

Service	Modular Energy Management solutions for your production	C.2
	Diagnosis audit for the introduction of ISO 50001	C.3
	Energy audit DIN EN 16247-1	C.4
	Energy data input system check	C.5
	Energy law in brief	C.6
	Subsidy check	C.7
	Energy-efficiency analysis	C.8
	Energy concept starter	C.9
	Load profile analysis (electricity/gas/heating)	C.10
	EnPI check in accordance with ISO 50006	C.11
	Service	C.12

Modular Energy Management solutions for your production

Services for your success

C As an experienced Energy Management team, we offer a comprehensive range of tailored services alongside the hardware and software components described. In doing so, we help you to achieve greater energy-efficiency as well as compliance in accordance with ISO 50001.

It goes without saying that the support we provide you is unique and tailored to your company in the form of an energy-efficiency consultation as well as planning all the way through to the integration of your management system.

On request we will support your audits and assist you with applications. We are also happy to support you as an external Energy Management agency.



Our portfolio of services is specific to each country. Please feel free to contact your local Weidmüller team if you have any questions.



Diagnosis audit for the introduction of ISO 50001

Systematically reduce your energy consumption and costs!

Optimise your energy costs!

In accordance with the German laws governing the expansion of renewable energies (EEG), the taxation of power and energy, and energy services and other energy-efficiency measures, large companies have been required to provide DIN EN ISO 50001 (energy management) or EMAS (environmental management) registration since 2015 at the latest in order to benefit from tax relief or an EEG subsidy.



Challenge

In order to introduce an energy management system pursuant to ISO 50001 effectively and efficiently you need to know where you stand. The interesting question when introducing an energy management system is the extent to which you would already comply with standards if you were to continue to operate as you have been. We have developed a standards-based diagnosis audit in order to answer this question.

We provide you with a solution!

The informative diagnosis audit gives you a complete project plan for introducing an energy management system pursuant to DIN EN ISO 50001 at your company. Experienced auditors identify cases of non-compliance and weaknesses, and a detailed timeline with information on work packages and internal and external workloads provides you with a basis for a thorough cost/benefit analysis.

Service specifications

The following services are included:

- Conducting a diagnosis audit in order to optimise your management system, particularly with respect to your external certification in accordance with ISO 50001
- Identification of cases of non-compliance and weaknesses by experienced auditors
- Preparation of a thorough audit report with concrete recommendations for successful certification
- Planning of work packages

Overview of the most important services

1. Preparation of stock-taking
2. Determination of the production and organisation structure
3. Reviewing management documents
4. Documenting the energy structure
5. Defining potential balance sheet and system thresholds
6. Clarifying responsibilities
7. Determining the workload required to introduce an EnMS
8. Producing a project plan
9. Coordination of work packages
10. Providing information regarding potential subsidies

Energy audit DIN EN 16247-1

Short-term reductions in energy consumption thanks to an energy audit

Challenge

C

With the exception of small and medium-sized enterprises (SMEs), since 2015 all companies have been required to introduce an energy audit pursuant to EN 16247-1 or an EnMS in accordance with ISO 50001 or EMAS. An energy audit pursuant to DIN EN 16247-1 has also been mandatory for SMEs in the manufacturing sector since 2013 in order to receive tax relief.

The energy audit is an important tool for identifying measures to improve energy-efficiency and reduce energy-related costs. Determining how much energy is consumed and where within the company also reveals where consumption could potentially be reduced. The economic benefit of the energy audit is therefore not to be underestimated. Weidmüller can help you conduct an energy audit in accordance with the applicable standards in order to improve energy-efficiency at multiple locations.



Service specifications

The purpose of the energy audit is to identify energy-efficiency measures and interdependencies within production. The cost-effectiveness of individual, relevant measures is also calculated.

The following services are included:

- Detailed planning of the itinerary for the audit, with an inspection of the relevant areas or departments and an audit of the documented information
- Systematic investigation of energy usage and consumption
- Description of the audit findings and evaluation of potential courses of action
- Proof of changes in efficiency and the use of energy

The energy audit is broken down into the following steps:

1. Kick-off meeting
2. Data input
3. Field assignment
4. Analysis
5. Report
6. Wrap-up meeting



Contact us for a quote regarding your pending energy audit – energy@weidmueller.com

Energy data acquisition system check

Lay the foundation for energy-efficiency now

Challenge

Would you like your company to be more energy-efficient? Is certainty with respect to planning and investment important to you when it comes to measuring your energy data? Then an individual initial energy data input consultation is for you.

Trust Weidmüller

Weidmüller's energy management team comprises leading energy consultants, management representatives and auditors for energy management systems.

Countless errors can arise when selecting measuring technology, from interfaces through to monitoring software. We recommend courses of action.

As part of the system check we assess your options for subsidies. We also assist you with the application process.

Service specifications

The purpose of the energy data input system check is to determine and show a measuring point and measuring technology concept as the basis for building up your energy monitoring system.

The following services are included:

- Selection and inspection of measuring points
- Stock-take of existing meters and their suitability as well as their retrofittability for data transmission
- Stock-take of existing data transmission channels
- Compilation of a measuring technology concept
- Preparation of a report on findings with advice on subsidies

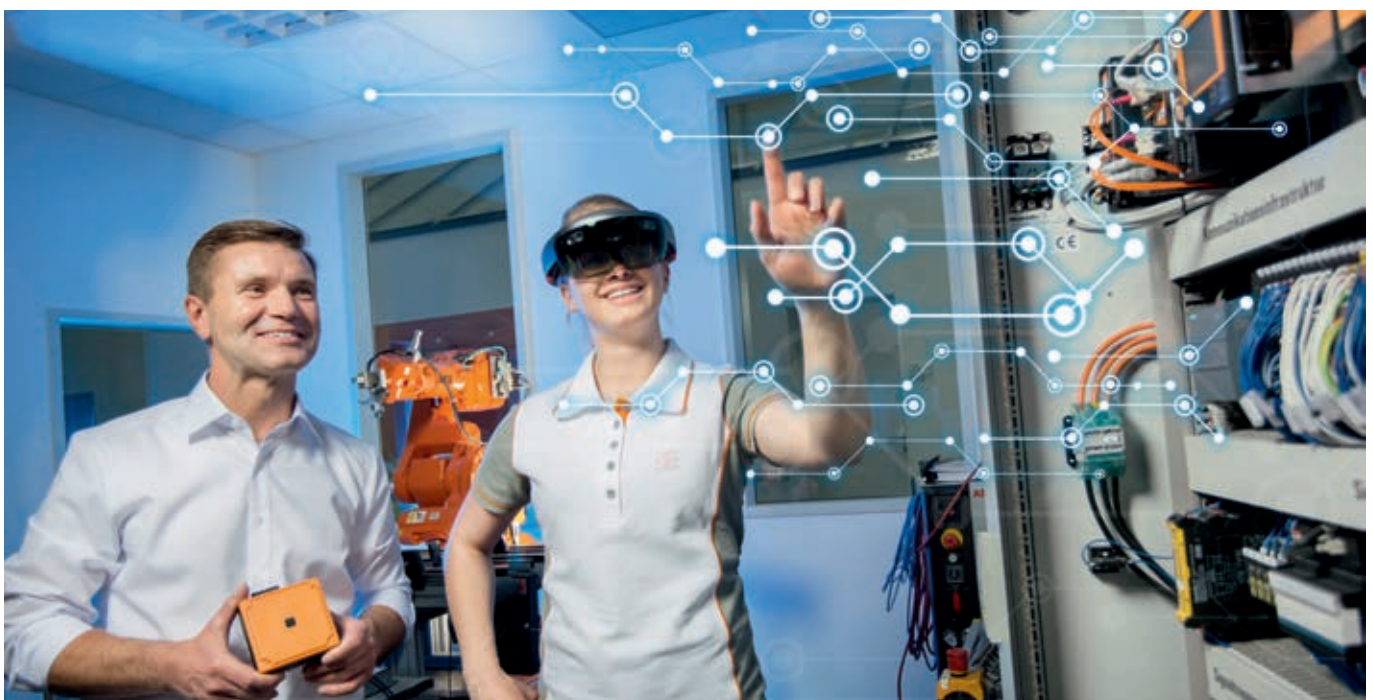

Energy law in brief

Secure government benefits and comply with deadlines under energy law

Maintain an overview

Have you ever missed a relevant deadline or forgotten to submit an important application to receive a government benefit?

The new energy era is changing and in some cases increasing the legal requirements and obligations for companies.

Are you really familiar with all of the requirements? What deadlines does your company need to comply with? What are the consequences if important deadlines are missed? What are the options for using government benefits to reduce energy costs? Anyone who does not regularly take advantage of government benefits is giving away money and putting themselves at a disadvantage in relation to the competition.

Service specifications

The purpose of the energy law in brief module is to offer advice on statutory obligations and potential government benefits that is tailored to your company's specific needs.

The following services are included:

- Advice on statutory obligations in the field of energy law
- Preparation of a customised overview (deadline calendar) containing all deadlines that are relevant to you in the field of energy law
- Advice on potential government benefits

The benefits to you with Weidmüller

Valuable edge with respect to knowledge

Be among the first to find out about the latest developments in the field of energy law and subsidies. Learn about the background to statutory obligations and the concrete consequences for your company.

Integration with technical requirements

Receive concrete pointers on how the framework of energy law can influence decisions at your company, and how to prepare for the future.



Subsidy check

Transparent presentation of potential subsidies

Maintain an overview

How annoying when the competition gains an advantage from government support. Are you experiencing an investment backlog with respect to your efficiency measures on account of your company's economic situation? The German federal government's subsidy database currently lists more than 200 subsidy programmes that few people are able to keep an overview of. The big players with their large legal departments are already taking full advantage of government benefits and subsidies. Those without the requisite knowledge soon join the ranks of the losers on account of the complexity involved.

Never miss out on subsidies again

You receive advice on subsidies and potential government benefits that is tailored to your company's specific needs.

Our extensive practical experience and excellent network with politicians and associations guarantees you a critical perspective outside the box. Always find out immediately about current developments in the field of energy law. That way you will never miss out on subsidies again.

Service specifications

The purpose of the subsidy check is to provide a thorough and transparent overview of the subsidies that can potentially be taken advantage of for corresponding measures.

The following services are included:

- Identifying and documenting potential subsidies
- Selecting subsidised projects based on the potential subsidies and chances of success
- Determining the exact volume of subsidies to be expected provided the volume of investment can already be estimated

The benefits to you with Weidmüller

Tried-and-tested solutions only

There is no "would have, could have, should have" here, only solutions that are really relevant to your company and your daily work. Numerous successful efficiency projects give Weidmüller the background knowledge required to understand your specific sector.

Years of experience

We put our Weidmüller experts at your disposal, with their years of experience from numerous efficiency projects. This gives you the expertise you need to identify your best possible options for receiving subsidies.

C



Energy-efficiency analysis

We can find potential savings for you

Receive valuable support

Saving energy is worth it. With advice from Weidmüller's specialists, you benefit from years of experience in the sector that offers genuine added value:

1. More profit thanks to lower costs for electricity, heating and cooling
2. Greater transparency regarding your energy media
3. Enhanced competitiveness and an important contribution to protecting the climate

Saving energy does not cost a lot

It is usually possible to significantly improve your company's energy-efficiency with just a small amount of investment – and in so doing reduce your overheads. Our energy-efficiency engineers will help you identify the most cost-effective measures to save energy. Weidmüller has been a leading provider of energy-efficiency solutions for many years now. This wide range of practical knowledge is currently giving rise to efficiency projects throughout Germany that are reducing long-term energy costs and impressing our customers.

As an SME you are not required to fund the costs for the expert panel alone. We will identify subsidies for you and help you with the application process.

Service specifications

The purpose of the energy-efficiency analysis is to work with you to identify potential savings and evaluate their economic benefit.

The following services are included:

- Assessing potential savings and evaluating their economic benefit
- Documenting methods and measures
- Weidmüller can also help your company obtain government subsidies in connection with the BAFA programme "Energy-related advice in the SME sector"

Trust Weidmüller

SME experts

Benefit from the best possible subsidies. We are familiar with your sector, the market and all of your options for improving energy-efficiency at your company at an affordable cost. With our holistic advice and seamless cooperation with politicians and certifiers, we enable you to exploit all of the available potential no matter how small.

Benefit twice over

We will also not leave you on your own when it comes to implementation. Not only will we show you what is theoretically possible, but also assist you with your subsequent project, including as a consultant if necessary.



Energy concept starter

Your package for efficient power generation

More efficient systems

Dedicated power generation facilities quickly pay off for many companies. Whether it's electricity, heat, cooling, steam or compressed air: many such facilities have already been running reliably for a long time.

As in most cases, a lot has happened on the consumer side during this time:

- Is the facility running at a good operating point?
- Are the generator facilities still adequate with respect to demand?

The energy concept starter module gives you important approaches to optimisation and improving efficiency – for example by means of the following measures:

- Analysing your current and future requirements based on temperature curves and storage options
- recuperation options, coupling energy flows etc.
- Juxtaposing existing generator technologies and modern technologies
- Checking interdependencies within the system
- Assessing the use of renewable energies (optional)

Service specifications

The purpose of the energy concept starter is to identify ways to optimise your power generation.

The following services are included:

- Analysis of your current and future energy requirements
- Juxtaposing existing generator technologies and modern technologies
- Checking interdependencies within the system
- On request: Assessing the use of renewable energies

Greater cost-effectiveness

Not only has a lot changed on the technical side, but as a facility operator you also face a lot of new developments in terms of legislation, whether it's in relation to the procurement of primary energy sources such as natural gas or electricity, the combined generation of power and heat, or feeding in from PV installations.

Gain a thorough legal overview and remain up-to-date regarding tax rebates, relief and exemptions.



Load profile analysis (electricity/gas/heating)

Achieving lasting transparency and reducing energy-related costs

Expensive peak loads

Peak loads occur in many companies. Many energy suppliers charge extra for them. You would no doubt like to avoid unpleasant surprises in your energy bill, as well as unnecessary back-payments.

The Weidmüller load profile analysis gives you the necessary transparency for this on a regular basis, with precision and speed. New potential savings are also identified at the same time.

Smart solution

Extensive algorithms are used to precisely diagnose regular deviations in your consumption of energy or media. This does not involving carrying out any time-consuming measurements. Your energy provider supplies all of the data. You will be amazed at what you can tell from often indecipherable and confusing load profiles from your energy supplier.

Service specifications

The purpose of the load profile analysis is the fast and efficient analysis of energy data in order to make your company more efficient using existing data.

The following services are included:

- Fast, targeted and secure analysis of load profiles and their visualisation
- Expert appraisals and recommendations from our specialists regarding potential cost savings, identification of consumption potential and recommendations for how to proceed
- Clear presentation in the form of an informative report

The benefits to you with Weidmüller

Identifying potential savings directly

Your analyses are translated into informative visualisations. Potential savings are made immediately visible using informative 3D mountain ranges or spectral analyses.

Leading engineering expertise

Your energy consumption patterns are diagnosed using extensive algorithms. At the same time, you receive pointers from experienced engineers regarding potential energy savings.

Regular management reports

You regularly receive graphical evaluations and analyses. Your employees are made more aware of energy consumption at your company.

Continuous monitoring

You receive your analysed data within a week of billing. This allows you to identify weaknesses and potential without delay. Each new bill increases the level of transparency.

Indicators for your energy management system

The specified indicators can easily be used for your energy management system and energy cockpit.

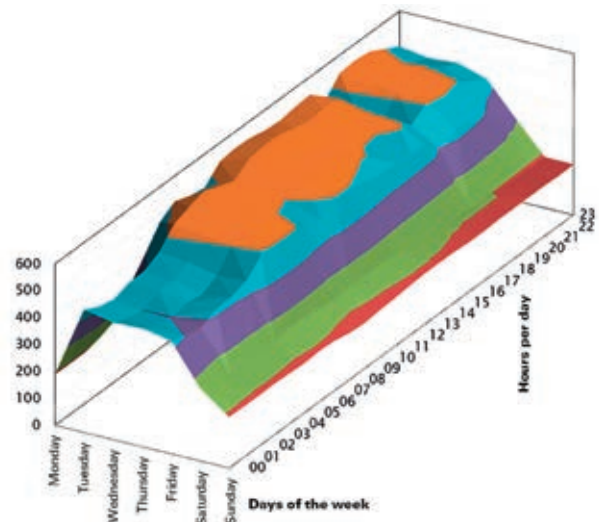

EnPI check in accordance with ISO 50006

Certified security by checking your energy figures

Demonstrating improvements

ISO 50006 imposes stricter requirements for energy management systems pursuant to DIN EN ISO 50001. Your auditor must verify and confirm the ongoing improvement of energy-efficiency as part of the certification audit. Energy figures based on continuous measurements to analyse and monitor energy-efficiency and its demonstrated improvement play a key role in accordance with ISO 50006.

Substantial risks

Even experienced energy managers appear uncertain regarding the mathematical methodology as well as the creation of proper energy performance indicators (EnPIs). The risk of losing certification is always present. For example because the improvement in energy-efficiency was not sufficiently documented or demonstrated using sample testing.

Solutions

The EnPI check is the digital solution for minimising obligations, difficulties and increased workloads arising in connection with demonstrating improvements in energy-efficiency. Our engineers analyse and document your energy-related improvements for you. We assess the adequacy of the indicators you have created and their respective interdependencies based on the data you supply.

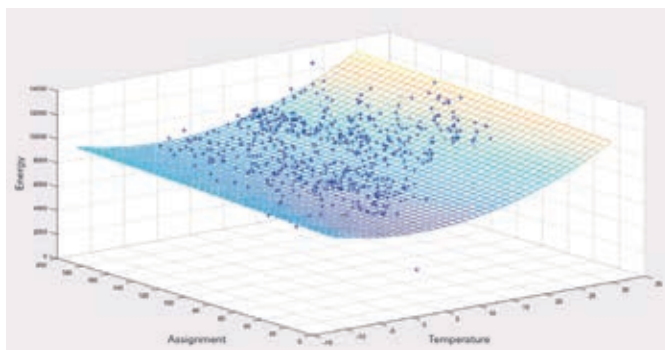

Service specifications

The purpose of the EnPI check is to help the client meet the requirements of DIN ISO 50006. Weidmüller helps the client to plausibly and clearly demonstrate an improvement in their energy-related performance.

The following services are included:

- Detailed coordination with the client regarding existing indicators, potential fixed and variable factors and definition of the number of analyses
- Data analysis, reporting and result interpretation in accordance with DIN ISO 50006
- Presentation of the report on results and handover of the prepared information as a PDF document

The benefits to you with Weidmüller

1. Energy-efficiency matrix

- Definition of appropriate energy performance indicators and energy-related consistencies
- Checking consistencies

2. Correlation analysis

- Analysis of the inclusion of defined energy and reference parameters
- Statistical analysis of energy and reference parameters

3. Further measures

- Proposals for new energy performance indicators and potential targets
- Adjustment of the baseline

Our expertise for your requirements

Service connects – worldwide

C Automation technology functions are becoming more complex in a globally-oriented world facing ambitious targets in terms of energy efficiency and smart production. We are your equal partners for the best connections in Industrial Connectivity. Our worldwide network of industrial managers for machine construction, process automation, energy and traffic engineering and for device manufacturers know the challenges you face and can support you in your specific applications.

Training course on technologies, applications and the detailed functionality of our products is available to you locally or at our headquarter in Germany. Our personal support can answer any questions reliably and expertly. Our online services are available 365 day a year around the clock to provide answers to your questions on our products - from user documentation through software to planning tools.

In short: Weidmüller's global service combines our expertise with your requirements.





Professional advice on planning

Our global network of industrial managers has extensive experience in automation technology and electrical connectivity. This expertise allows us to assist you with advice and planning support in order to work with you on resolving the everyday challenges of your applications.



Technology and application training

Industrial automation is moving towards smart production. It faces the challenges of new technologies and applications. Our varied range of training courses develops this knowledge further or provides more in-depth information on the handling of our products and solutions. Our seminars are modular and can be customised. We can train you and your employees in our academy, on your premises if you wish or online in our webinars at any time.



Customised installation

The challenges for the future are reducing costs and increasing efficiency. This requires intelligent, individual solutions which are tailored to your requirements. We can offer a highly qualified customer-specific production service in our application centre. Whether you need modified products, pre-assembled terminal rails or complete small cabinets: we produce the solutions developed for your application quickly and flexibly.

Online support and downloads

Exactly the right help and information on our solutions and products

C

If our products are used in your automation technology applications, you need the best possible individual support, from planning through installation to operation.

For every stage of your application, we can offer the right tools and information for our products and solutions. Up-to-date, uncomplicated, comprehensive and around the clock via our service portal at www.weidmueller.com/service.

Fast access to our support and services is available via Weidmüller webcodes. Simply select the service you want on the right hand side, then enter the webcode made up of five digits with a preceding hashtag into the search field in the top right corner of www.weidmueller.com and it will bring up the details you need.



Online and personal support

From planning through installation to operation, we can provide exactly the right help and information for each step of your application based on our solutions and products: up-to-date, uncomplicated and comprehensive, around the clock, online or in person.



Visit our website
for more information

www.weidmueller.de/service

Let's connect.

Engineering Support

As a developer, you need simple processes and system-wide tools. We support you in your development environment with comprehensive data, software tools and interfaces, product selection guides and development samples.

Technical data and downloads

Download all the documents and software relating to our products by simply entering the item number. You can also view our Online Catalogue and research the technical properties of our products.

Commercial support

Integrate our product data into your commercial system using standardised interfaces or familiarise yourself with the wide range of products in our technical catalogues.



Engineering data
Webcode #01219



Find downloads
Webcode #11379



Electronic catalogue in BMECat format and other formats
Webcode #11378



Product software
Webcode #01212



Products in the Online Catalogue
Webcode #01217



Access our Webshop
Webcode #11382



Whitepaper for device connectivity
Webcode #11359



Security Advisory Board
Webcode #11424



Technical catalogue in PDF Format
Webcode #01218

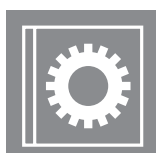

Engineering software
Webcode #11377

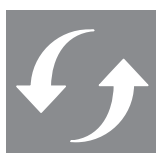

Product Change Notification
Webcode #11425



Product configurators, product selection guides and samples
Webcode #01214

More offers in online support and downloads

Not found what you are looking for? We have even more to offer you in online support and downloads.



Approvals, certificates and declaration of conformity
Webcode #11374

Here you will find information on the CE declaration of conformity, on RoHS and REACH and other company related certificates and approvals.

Index

Index	Index Type	X.2
	Index Order No.	X.3
	Addresses worldwide	X.4



Type	Order No.	Page
------	-----------	------

C

CMA-1056-1000-5A-15VA-1	1516870000	A.49
CMA-1056-1000-5A-2,5VA5	2420870000	A.49
CMA-1056-1200-5A-15VA-1	1516850000	A.49
CMA-1056-1200-5A-5VA-05	2421390000	A.49
CMA-1056-1500-5A-10VA-1	2420810000	A.49
CMA-1056-1500-5A-5VA-05	2420860000	A.49
CMA-1056-1600-5A-30VA-1	1516820000	A.49
CMA-1056-1600-5A-5VA-05	2420850000	A.49
CMA-1056-2000-5A-30VA-1	2420880000	A.49
CMA-1056-2000-5A-5VA-05	2420840000	A.49
CMA-1056-2500-5A-30VA-1	2420790000	A.49
CMA-1056-2500-5A-5VA-05	2420830000	A.49
CMA-1056-3000-5A-5VA-05	2420820000	A.49
CMA-1056-4000-5A-30VA-1	1516840000	A.49
CMA-1056-800-5A-10VA-1	1516880000	A.49
CMA-1056-800-5A-5VA-05	2420880000	A.49
CMA-205-100-5A-1VA-1	2420700000	A.58
CMA-205-150-5A-1,25VA-1	2420690000	A.58
CMA-205-200-5A-1,5VA-1	2420680000	A.58
CMA-205-250-5A-2,5VA-1	2420670000	A.58
CMA-22-100-5A-1,5VA-1	2421070000	A.51
CMA-22-100-5A-2,5VA-0,5	1482150000	A.51
CMA-22-150-5A-1,5VA-1	2421060000	A.51
CMA-22-200-5A-2,5VA-0,5	2421110000	A.51
CMA-22-200-5A-2,5VA-1	2421370000	A.51
CMA-22-200-5A-2,5VA-0,2	2461270000	A.51
CMA-22-250-5A-2,5VA-0,2	2461280000	A.51
CMA-22-250-5A-5VA-0,5	1482170000	A.51
CMA-22-250-5A-5VA-1	2421050000	A.51
CMA-22-300-5A-2,5VA-0,2	2461290000	A.51
CMA-22-300-5A-5VA-0,5	2421000000	A.51
CMA-22-300-5A-5VA-1	2421040000	A.51
CMA-22-400-5A-2,5VA-0,2	2461300000	A.51
CMA-22-400-5A-5VA-0,5	2421010000	A.51
CMA-22-50-5A-1VA-1	2421100000	A.51
CMA-22-500-5A-2,5VA-0,2	2461310000	A.51
CMA-22-500-5A-5VA-0,5	1482220000	A.51
CMA-22-60-5A-1,5VA-1	1482140000	A.51
CMA-22-600-5A-2,5VA-0,2	2461330000	A.51
CMA-22-600-5A-5VA-0,5	1482180000	A.51
CMA-22-75-5A-1,5VA-1	2421080000	A.51
CMA-31-100-5A-2,5VA-1	1482030000	A.48
CMA-31-150-5A-2,5VA-0,5	2421030000	A.48
CMA-31-150-5A-5VA-1	2420960000	A.48
CMA-31-200-5A-2,5VA-0,5	2421020000	A.48
CMA-31-200-5A-5VA-1	2420950000	A.48
CMA-31-250-5A-5VA-0,5	1482050000	A.48
CMA-31-250-5A-5VA-1	2420940000	A.48
CMA-31-300-5A-5VA-0,5	2420990000	A.48
CMA-31-400-5A-5VA-0,5	2420980000	A.48
CMA-31-400-5A-5VA-1	2420920000	A.48
CMA-31-500-5A-5VA-0,5	1482070000	A.48
CMA-31-500-5A-5VA-1	2420910000	A.48
CMA-31-60-5A-1,25VA-1	2421380000	A.48
CMA-31-600-5A-5VA-0,5	2420970000	A.48
CMA-31-600-5A-5VA-1	2420900000	A.48
CMA-31-75-5A-2,5VA-1	1482040000	A.48
CMA-31-750-5A-5VA-0,5	1482080000	A.48
CMA-31-750-5A-5VA-1	2420890000	A.48
CMA-310-300-5A-3,75VA-1	2420660000	A.59
CMA-310-400-5A-5VA-1	2420650000	A.59
CMA-310-500-5A-5VA-1	2420610000	A.59
CMA-310-600-5A-5VA-1	2420600000	A.59
CMA-58-600-1A-2,5VA-0,5	2464810000	A.56
CMA-812-15-5A-15VA-1	2438470000	A.55
CMA-812-15-5A-7,5VA-0,5	2438480000	A.55
CMA-812-600-1A-2,5VA-05	2464820000	A.55
CMA-CTM-7-32-1A-02VA-1	2525150000	A.50
CMA-CTM-7-35-1A-02VA-1	2486490000	A.50
CMA-CTM-7-40-1A-03VA-1	2556040000	A.50
CMA-CTM-7-50-1A-04VA-1	2556030000	A.50
CMA-CTM-7-60-1A-04VA-1	2556020000	A.50
CMA-CTM-7-64-1A-05VA-1	2556010000	A.50
CMA-CTM-7-SNAP-ON	2525160000	A.50

D

DEK 5/8-11.5 MC NE WS	1341630000	A.41
DEK 5/8-11.5 MC NE WS	1341630000	A.43
DEK 5/8-11.5 MC SDR	1341610000	A.41
DEK 5/8-11.5 MC SDR	1341610000	A.43

E

EM-Connectivity-Box 144	8000028952	A.63
EM-Connectivity-Box 96	8000028950	A.63
EM-Connectivity-Box TS	8000028951	A.63
ENERGY ANALYSER 550-230	2425500000	A.17
ENERGY ANALYSER 550-230	2425500000	A.33
ENERGY ANALYSER 550-24	2602580000	A.17
ENERGY ANALYSER 550-24	2602580000	A.33
ENERGY ANALYSER 750-230	2534130000	A.17
ENERGY ANALYSER 750-230	2534130000	A.34
ENERGY ANALYSER 750-24	2534160000	A.17
ENERGY ANALYSER 750-24	2534160000	A.34
ENERGY ANALYSER D550-230	2425510000	A.17
ENERGY ANALYSER D550-230	2425510000	A.32

Type	Order No.	Page
------	-----------	------

ENERGY ANALYSER D550-24	2489780000	A.17
ENERGY ANALYSER D550-24	2489780000	A.32
ENERGY LOGGER D650	2425520000	A.17
ENERGY LOGGER D650	2425520000	A.37
ENERGY LOGGER 50 MODULE	2446170000	A.37
ENERGY METER 330	2425410000	A.17
ENERGY METER 330	2425410000	A.21
ENERGY METER 350	2425420000	A.17
ENERGY METER 350	2425420000	A.21
ENERGY METER 520-230	2500880000	A.17
ENERGY METER 520-230	2500880000	A.22
ENERGY METER 520-24	2500860000	A.17
ENERGY METER 520-24	2500860000	A.22
ENERGY METER 525-230	2540890000	A.17
ENERGY METER 525-230	2540890000	A.23
ENERGY METER 525-24	2540880000	A.17
ENERGY METER 525-24	2540880000	A.23
ENERGY METER 610-230	2540850000	A.17
ENERGY METER 610-230	2540850000	A.24
ENERGY METER 610-24	2540920000	A.17
ENERGY METER 610-24	2540920000	A.24
ENERGY METER 610-PB-230	2540870000	A.17
ENERGY METER 610-PB-230	2540870000	A.25
ENERGY METER 610-PB-24	2540860000	A.17
ENERGY METER 610-PB-24	2540860000	A.25
ENERGY METER 700-PN-230	2500890000	A.17
ENERGY METER 700-PN-230	2500890000	A.26
ENERGY METER 700-PN-24	2500870000	A.17
ENERGY METER 700-PN-24	2500870000	A.26
ENERGY METER 750-230	2540910000	A.17
ENERGY METER 750-230	2540910000	A.27
ENERGY METER 750-24	2540900000	A.17
ENERGY METER 750-24	2540900000	A.27
ENERGY METER BRACKET B1	2433040000	A.33
ENERGY METER BRACKET B1	2433040000	A.34
ENERGY METER BRACKET L1	2433060000	A.23
ENERGY METER BRACKET L1	2433060000	A.24
ENERGY METER BRACKET L1	2433060000	A.25
ENERGY METER BRACKET L1	2433060000	A.26
ENERGY METER BRACKET L1	2433060000	A.27
ENERGY METER BRACKET S1	2433080000	A.21
ENERGY METER BRACKET S2	2433070000	A.22
ENERGY METER D370-CBM	2540830000	A.17
ENERGY METER D370-CBM	2540830000	A.20
ENERGY METER D650	2425490000	A.17
ENERGY METER D650	2425490000	A.20
ENERGY METER FIXING SET	2433030000	A.21
ENERGY METER FIXING SET	2433030000	A.22
ENERGY METER FIXING SET	2433030000	A.23
ENERGY METER FIXING SET	2433030000	A.24
ENERGY METER FIXING SET	2433030000	A.25
ENERGY METER FIXING SET	2433030000	A.26
ENERGY METER FIXING SET	2433030000	A.27
ENERGY METER SEAL L144	2495630000	A.33
ENERGY METER SEAL L144	2495630000	A.34
ENERGY METER SEAL L96-1	2495640000	A.21
ENERGY METER SEAL L96-2	2495610000	A.22
ENERGY METER SEAL L96-2	2495610000	A.23
ENERGY METER SEAL L96-2	2495610000	A.24
ENERGY METER SEAL L96-2	2495610000	A.25
ENERGY METER SEAL L96-2	2495610000	A.26
ENERGY METER SEAL L96-2	2495610000	A.27
ESO UR20 DIN A4 WS	1429430000	A.41
ESO UR20 DIN A4 WS	1429430000	A.43

I

IE-USB-A-MICRO-1.8M	1487980000	A.43
---------------------	------------	------

K

KCMA-18-100-1A-1,25VA-3	1482010000	A.52
KCMA-18-150-1A-2VA-3	2420770000	A.52
KCMA-18-200-1A-3VA-3	2420760000	A.52
KCMA-18-250-1A-1,5VA-1	1482000000	A.52
KCMA-18-250-1A-4VA-3	2420750000	A.52
KCMA-18-50-1A-1VA-3	1482020000	A.52
KCMA-18-75-1A-1VA-3	2420780000	A.52
KCMA-32-400-1A-5VA-1	1481990000	A.53
KCMA-32-400-5A-5VA-1	2420730000	A.53
KCMA-32-500-5A-5VA-1	2420740000	A.53
KCMA-32-600-1A-5VA-1	1481980000	A.53
KCMA-32-600-5A-5VA-1	2420720000	A.53
KCMA-44-1000-5A-5VA-1	2437400000	A.54
KCMA-44-750-5A-5VA-1	2420710000	A.54
KCMA-44-800-5A-5VA-1	2437370000	A.54
KDSM BHZ5.00	1483050000	A.41
KDSM BHZ5.00	1483050000	A.43

L

LST EM-BLOCK	8000028895	A.61
--------------	------------	------

P

PM 2.7/2.6 MC NE WS	1323710000	A.41
PM 2.7/2.6 MC NE WS	1323710000	A.43
PM 2.7/2.6 MC SDR	1323700000	A.41
PM 2.7/2.6 MC SDR	1323700000	A.43

Type	Order No.	Page
------	-----------	------

POWER MONITOR	1423550000	A.28
POWER MONITOR 51A	1470260000	A.28
POWER MONITOR BRACKET	2091060000	A.28

R

RCMA-B22-D125-1.5	2593380000	A.60
RCMA-B22-D125-4.5	2593350000	A.60
RCMA-B22-D175-1.5	2593390000	A.60
RCMA-B22-D175-4.5	2593360000	A.60
RCMA-B22-D70-1.5	2593370000	A.60
RCMA-B22-D70-4.5	2593340000	A.60
RCMC-5000-1A-P	2593400000	A.60
RCMC-5000-AQ-P	2593410000	A.60

T

THM UR20 GE	1429910000	A.41
THM UR20 GE	1429910000	A.43
THM UR20 WS	1429420000	A.41
THM UR20 WS	1429420000	A.43

U

UR20-3EM-230V-AC	2007420000	A.41
UR20-BM-SP	1350930000	A.41
UR20-EBK-ACC	1346610000	A.41
UR20-EBK-ACC	1346610000	A.43
UR20-EM-2007420000-SP	1562270000	A.41
UR20-FBC-MOD-TCR-V2	2476450000	A.43
UR20-PK-2007420000-SP	2068630000	A.41
UR20-PK-2476450000-SP	2485280000	A.43
UR20-SM-ACC	1339920000	A.41
UR20-SM-ACC	1339920000	A.43

W

WSK-30-10-5A-2,5VA-1	2556060000	A.57
WSK-30-15-5A-2,5VA-1	2556070000	A.57
WSK-30-20-5A-2,5VA-1	2556080000	A.57
WSK-30-5-5A-2,5VA-1	2556050000	A.57

Order No.	Type	Page
-----------	------	------

1320000000

1323700000	PM 2.7/2.6 MC SDR	A.41
1323700000	PM 2.7/2.6 MC SDR	A.43
1323710000	PM 2.7/2.6 MC NE WS	A.41
1323710000	PM 2.7/2.6 MC NE WS	A.43

1330000000

1339920000	UR20-SM-ACC	A.41
1339920000	UR20-SM-ACC	A.43

1340000000

1341610000	DEK 5/8-11.5 MC SDR	A.41
1341610000	DEK 5/8-11.5 MC SDR	A.43
1341630000	DEK 5/8-11.5 MC NE WS	A.41
1341630000	DEK 5/8-11.5 MC NE WS	A.43
1346610000	UR20-EBK-ACC	A.41
1346610000	UR20-EBK-ACC	A.43

1350000000

1350930000	UR20-BM-SP	A.41
------------	------------	------

1420000000

1423550000	POWER MONITOR	A.28
1429420000	THM UR20 WS	A.41
1429420000	THM UR20 WS	A.43
1429430000	ESO UR20 DIN A4 WS	A.41
1429430000	ESO UR20 DIN A4 WS	A.43
1429910000	THM UR20 GE	A.41
1429910000	THM UR20 GE	A.43

1470000000

1470260000	POWER MONITOR 51A	A.28
------------	-------------------	------

1480000000

1481980000	KCMA-32-600-1A-5VA-1	A.53
1481990000	KCMA-32-400-1A-5VA-1	A.53
1482000000	KCMA-18-250-1A-1,5VA-1	A.52
1482010000	KCMA-18-100-1A-1,25VA-3	A.52
1482020000	KCMA-18-50-1A-1VA-3	A.52
1482030000	CMA-31-100-5A-2,5VA-1	A.48
1482040000	CMA-31-75-5A-2,5VA-1	A.48
1482050000	CMA-31-250-5A-5VA-0,5	A.48
1482070000	CMA-31-500-5A-5VA-0,5	A.48
1482080000	CMA-31-750-5A-5VA-0,5	A.48
1482140000	CMA-22-60-5A-1,5VA-1	A.51
1482150000	CMA-22-100-5A-2,5VA-0,5	A.51
1482170000	CMA-22-250-5A-5VA-0,5	A.51
1482180000	CMA-22-600-5A-5VA-0,5	A.51
1482220000	CMA-22-500-5A-5VA-0,5	A.51
1483050000	KOSM BH25 00	A.41
1483050000	KOSM BH25 00	A.43
1487980000	IE-USB-A-MICRO-1.8M	A.43

1510000000

1516820000	CMA-1056-1600-5A-30VA-1	A.49
1516840000	CMA-1056-4000-5A-30VA-1	A.49
1516850000	CMA-1056-1200-5A-15VA-1	A.49
1516870000	CMA-1056-1000-5A-15VA-1	A.49
1516880000	CMA-1056-800-5A-10VA-1	A.49

1560000000

1562270000	UR20-EM-2007420000-SP	A.41
------------	-----------------------	------

2000000000

2007420000	UR20-3EM-230V-AC	A.41
------------	------------------	------

2060000000

2068630000	UR20-PK-2007420000-SP	A.41
------------	-----------------------	------

2090000000

2091060000	POWER MONITOR BRACKET	A.28
------------	-----------------------	------

2420000000

2420600000	CMA-310-600-5A-5VA-1	A.59
2420610000	CMA-310-500-5A-5VA-1	A.59
2420650000	CMA-310-400-5A-5VA-1	A.59
2420660000	CMA-310-300-5A-3,75VA-1	A.59
2420670000	CMA-205-250-5A-2,5VA-1	A.58
2420680000	CMA-205-200-5A-1,5VA-1	A.58
2420690000	CMA-205-150-5A-1,25VA-1	A.58
2420700000	CMA-205-100-5A-1VA-1	A.58
2420710000	KCMA-44-750-5A-5VA-1	A.54
2420720000	KCMA-32-600-5A-5VA-1	A.53
2420730000	KCMA-32-400-5A-5VA-1	A.53
2420740000	KCMA-32-500-5A-5VA-1	A.53
2420750000	KCMA-18-250-1A-4VA-3	A.52

Order No.	Type	Page
-----------	------	------

2420760000	KCMA-18-200-1A-3VA-3	A.52
2420770000	KCMA-18-150-1A-2VA-3	A.52
2420780000	KCMA-18-75-1A-1VA-3	A.52
2420790000	CMA-1056-2500-5A-30VA-1	A.49
2420800000	CMA-1056-2000-5A-30VA-1	A.49
2420810000	CMA-1056-1500-5A-10VA-1	A.49
2420820000	CMA-1056-3000-5A-5VA-05	A.49
2420830000	CMA-1056-2500-5A-5VA-05	A.49
2420840000	CMA-1056-2000-5A-5VA-05	A.49
2420850000	CMA-1056-1600-5A-5VA-05	A.49
2420860000	CMA-1056-1500-5A-5VA-05	A.49
2420870000	CMA-1056-1000-5A-2,5VA5	A.49
2420880000	CMA-1056-800-5A-5VA-0,5	A.49
2420890000	CMA-31-750-5A-5VA-1	A.48
2420900000	CMA-31-600-5A-5VA-1	A.48
2420910000	CMA-31-500-5A-5VA-1	A.48
2420920000	CMA-31-400-5A-5VA-1	A.48
2420940000	CMA-31-250-5A-5VA-1	A.48
2420950000	CMA-31-200-5A-5VA-1	A.48
2420960000	CMA-31-150-5A-5VA-1	A.48
2420970000	CMA-31-600-5A-5VA-0,5	A.48
2420980000	CMA-31-400-5A-5VA-0,5	A.48
2420990000	CMA-31-300-5A-5VA-0,5	A.48
2421000000	CMA-22-300-5A-5VA-0,5	A.51
2421010000	CMA-22-400-5A-5VA-0,5	A.51
2421020000	CMA-31-200-5A-2,5VA-0,5	A.48
2421030000	CMA-31-150-5A-2,5VA-0,5	A.48
2421040000	CMA-22-300-5A-5VA-1	A.51
2421050000	CMA-22-250-5A-5VA-1	A.51
2421060000	CMA-22-150-5A-1,5VA-1	A.51
2421070000	CMA-22-100-5A-1,5VA-1	A.51
2421080000	CMA-22-75-5A-1,5VA-1	A.51
2421100000	CMA-22-50-5A-1VA-1	A.51
2421110000	CMA-22-200-5A-2,5VA-0,5	A.51
24211370000	CMA-22-200-5A-2,5VA-1	A.51
24211380000	CMA-31-60-5A-1,25VA-1	A.48
24211390000	CMA-1056-1200-5A-5VA-05	A.49
2425410000	ENERGY METER 330	A.17
2425410000	ENERGY METER 330	A.21
2425420000	ENERGY METER 350	A.17
2425420000	ENERGY METER 350	A.21
2425490000	ENERGY METER D650	A.17
2425490000	ENERGY METER D650	A.20
2425500000	ENERGY ANALYSER 550-230	A.17
2425500000	ENERGY ANALYSER 550-230	A.33
2425510000	ENERGY ANALYSER D550-230	A.17
2425510000	ENERGY ANALYSER D550-230	A.32
2425520000	ENERGY LOGGER D550	A.17
2425520000	ENERGY LOGGER D550	A.37

2430000000

2433030000	ENERGY METER FIXING SET	A.21
2433030000	ENERGY METER FIXING SET	A.22
2433030000	ENERGY METER FIXING SET	A.23
2433030000	ENERGY METER FIXING SET	A.24
2433030000	ENERGY METER FIXING SET	A.25
2433030000	ENERGY METER FIXING SET	A.26
2433030000	ENERGY METER FIXING SET	A.27
2433040000	ENERGY METER BRACKET B1	A.33
2433040000	ENERGY METER BRACKET B1	A.34
2433060000	ENERGY METER BRACKET L1	A.23
2433060000	ENERGY METER BRACKET L1	A.24
2433060000	ENERGY METER BRACKET L1	A.25
2433060000	ENERGY METER BRACKET L1	A.26
2433060000	ENERGY METER BRACKET L1	A.27
2433070000	ENERGY METER BRACKET S2	A.22
2433080000	ENERGY METER BRACKET S1	A.21
2437370000	KCMA-44-800-5A-5VA-1	A.54
2437400000	KCMA-44-1000-5A-5VA-1	A.54
2438470000	CMA-812-15-5A-15VA-1	A.55
2438480000	CMA-812-15-5A-7,5VA-0,5	A.55

2440000000

2446170000	ENERGY LOGGER S0 MODULE	A.37
------------	-------------------------	------

2460000000

2461270000	CMA-22-200-5A-2,5VA-0,2	A.51
2461280000	CMA-22-250-5A-2,5VA-0,2	A.51
2461290000	CMA-22-300-5A-2,5VA-0,2	A.51
2461300000	CMA-22-400-5A-2,5VA-0,2	A.51
2461310000	CMA-22-500-5A-2,5VA-0,2	A.51
2461330000	CMA-22-600-5A-2,5VA-0,2	A.51
2464810000	CMA-58-600-1A-2,5VA-0,5	A.56
2464820000	CMA-812-600-1A-2,5VA-0,5	A.55

2470000000

2476450000	UR20-FBC-MOD-TCPV2	A.43
------------	--------------------	------

2480000000

2485280000	UR20-PK-2476450000-SP	A.43
2486490000	CMA-CTM-7-35-1A-02VA-1	A.50
2489780000	ENERGY ANALYSER D550-24	A.17
2489780000	ENERGY ANALYSER D550-24	A.32

Order No.	Type	Page
-----------	------	------

2490000000

2495610000	ENERGY METER SEAL L96-2	A.22
2495610000	ENERGY METER SEAL L96-2	A.23
2495610000	ENERGY METER SEAL L96-2	A.24
2495610000	ENERGY METER SEAL L96-2	A.25
2495610000	ENERGY METER SEAL L96-2	A.26
2495610000	ENERGY METER SEAL L96-2	A.27
2495630000	ENERGY METER SEAL L144	A.33
2495630000	ENERGY METER SEAL L144	A.34
2495640000	ENERGY METER SEAL L96-1	A.21

2500000000

2500860000	ENERGY METER 520-24	A.17
2500860000	ENERGY METER 520-24	A.22
2500870000	ENERGY METER 700-PN-24	A.17
2500870000	ENERGY METER 700-PN-24	A.26
2500880000	ENERGY METER 520-230	A.17
2500880000	ENERGY METER 520-230	A.22
2500890000	ENERGY METER 700-PN-230	A.17
2500890000	ENERGY METER 700-PN-230	A.26

2520000000

2525150000	CMA-CTM-7-32-1A-02VA-1	A.50
2525160000	CMA-CTM-7-SNAP-ON	A.50

2530000000

2534130000	ENERGY ANALYSER 750-230	A.17
2534130000	ENERGY ANALYSER 750-230	A.34
2534160000	ENERGY ANALYSER 750-24	A.17
2534160000	ENERGY ANALYSER 750-24	A.34

2540000000

2540830000	ENERGY METER D370-CBM	A.17
2540830000	ENERGY METER D370-CBM	A.20
2540850000	ENERGY METER 610-230	A.17
2540850000	ENERGY METER 610-230	A.24
2540860000	ENERGY METER 610-PB-24	A.17
2540860000	ENERGY METER 610-PB-24	A.25
2540870000	ENERGY METER 610-PB-230	A.17
2540870000	ENERGY METER 610-PB-230	A.25
2540880000	ENERGY METER 525-24	A.17
2540880000	ENERGY METER 525-24	A.23
2540890000	ENERGY METER 525-230	A.17
2540890000	ENERGY METER 525-230	A.23
2540900000	ENERGY METER 750-24	A.17
2540900000	ENERGY METER 750-24	A.27
2540910000	ENERGY METER 750-230	A.17
2540910000	ENERGY METER 750-230	A.27
2540920000	ENERGY METER 610-24	A.17
2540920000	ENERGY METER 610-24	A.24

2550000000

2556010000	CMA-CTM-7-64-1A-05VA-1	A.50
2556020000	CMA-CTM-7-60-1A-04VA-1	A.50
2556030000	CMA-CTM-7-50-1	

Addresses worldwide

Let's connect.

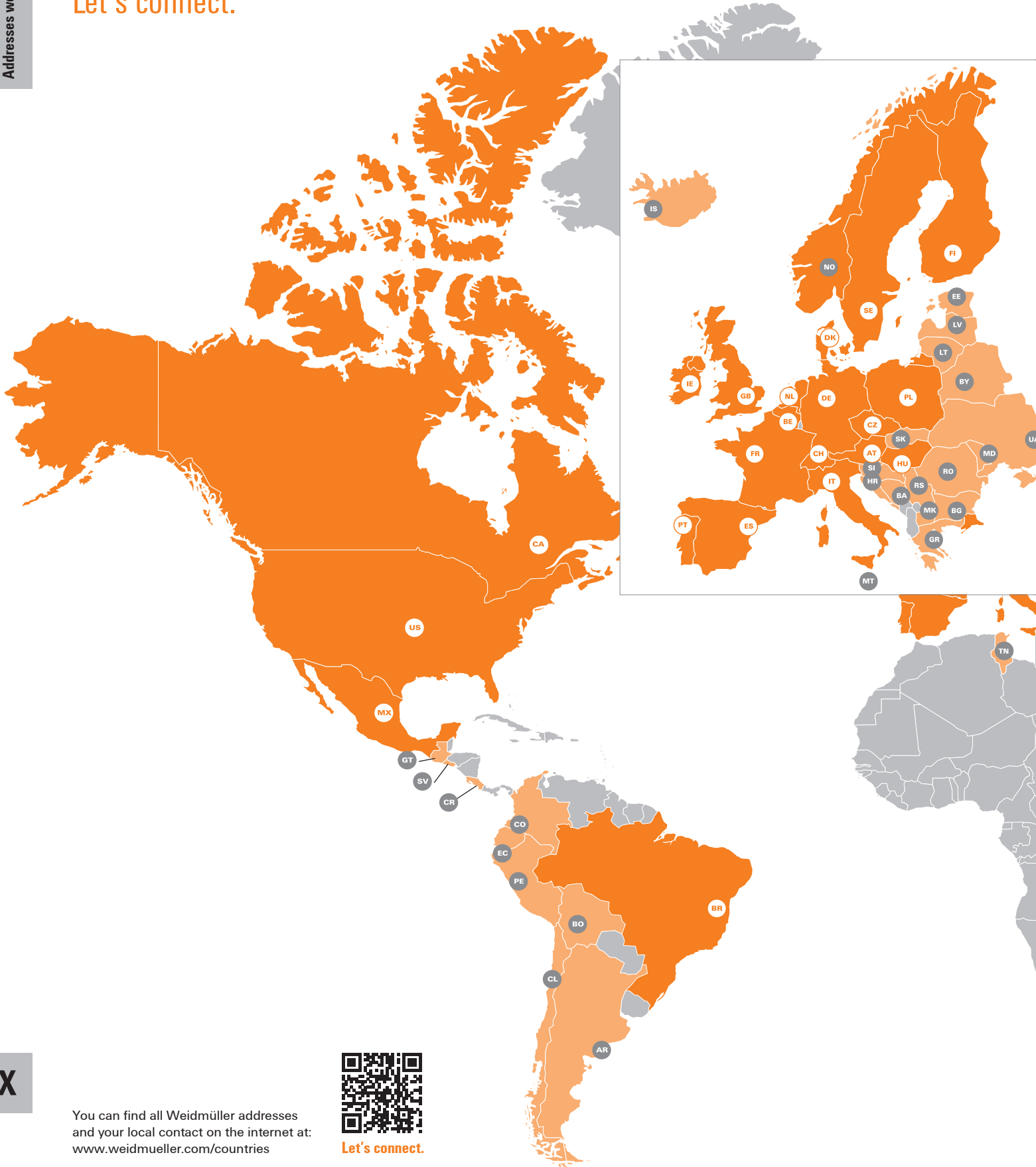

X

You can find all Weidmüller addresses and your local contact on the internet at: www.weidmueller.com/countries



Let's connect.

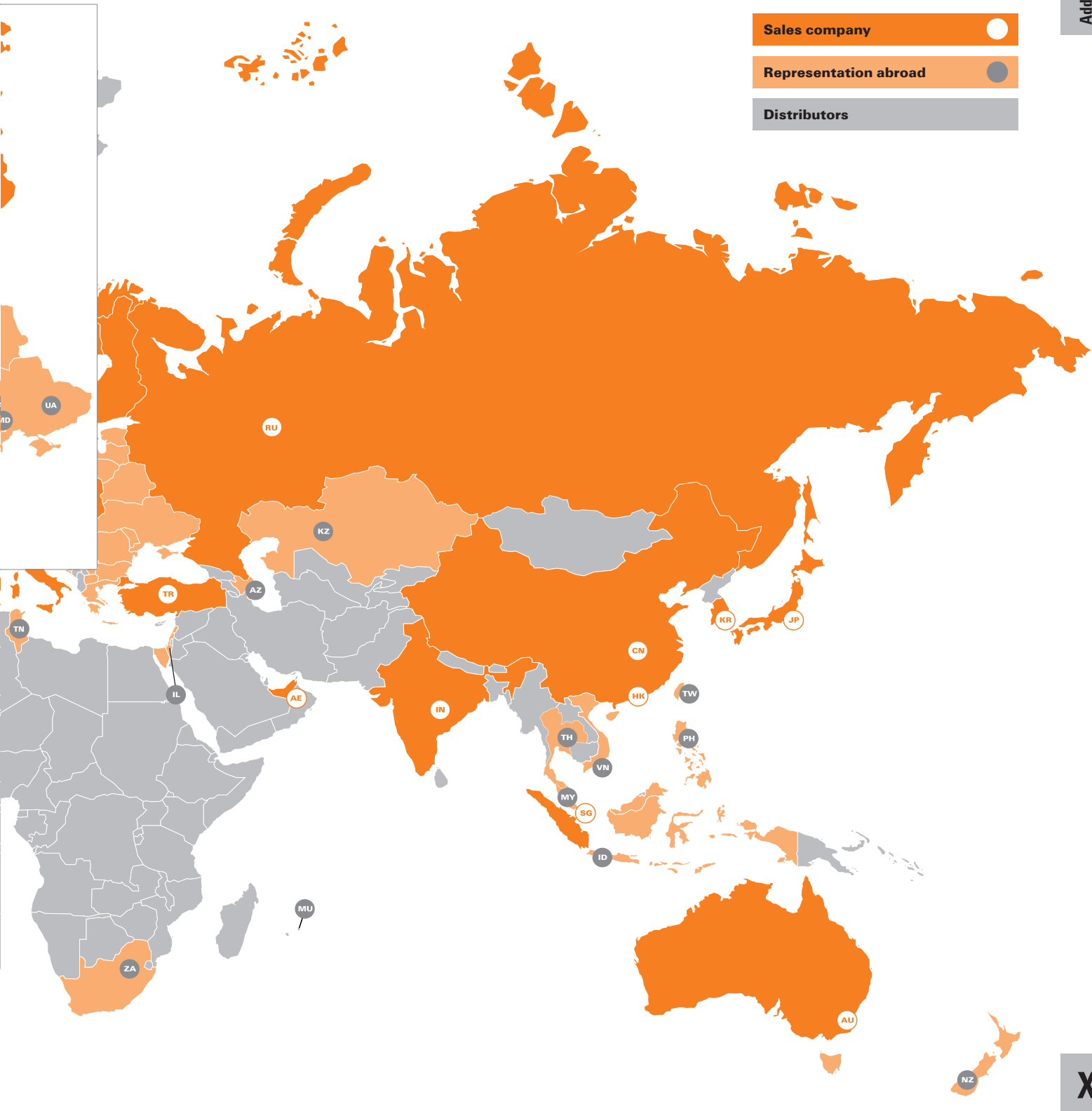

We cannot guarantee that there are no mistakes in the publications or software provided by us to the customer for the purpose of making orders. We try our best to quickly correct errors in our printed media.

X

All orders are based on our general terms of delivery, which can be reviewed on the websites of our group companies where you place your order. On demand we can also send the general terms of delivery to you.

Weidmüller – Your partner in Industrial Connectivity

As experienced experts we support our customers and partners around the world with products, solutions and services in the industrial environment of power, signal and data. We are at home in their industries and markets and know the technological challenges of tomorrow. We are therefore continuously developing innovative, sustainable and useful solutions for their individual needs. Together we set standards in Industrial Connectivity.

Technical Guide

More detailed information on our measuring and monitoring systems is available on our website. In addition we offer a Technical Guide with comprehensive technical basic knowledge related to the subject of energy monitoring.

www.weidmueller.com/energymonitoring

Weidmüller Interface GmbH & Co. KG
Klingenbergstraße 16
32758 Detmold, Germany
T +49 5231 14-0
F +49 5231 14-292083
www.weidmueller.com

Personal support can
be found on our website:
www.weidmueller.com/contact

Made in Germany



Order number: 2596940000/08/2018/MRM